



User Manual

105U Radio Telemetry Module

105S Serial Telemetry Module

For 105U-C product, refer to separate User Manuals

ELPRO Technologies Pty Ltd, 9/12 Billabong Street, Stafford Q 4053, Australia.

Tel: +61 7 33524533 Fax: +61 7 33524577 Email: sales@elpro.com.au

Web: www.elprotech.com or www.elpro.com.au

Thank you for your selection of the 105 module for your telemetry needs. We trust it will give you many years of valuable service.

ATTENTION!

Incorrect termination of supply wires may cause internal damage and will void warranty.

To ensure your 105 enjoys a long life,
**double check ALL your connections with
the user's manual**

before turning the power on.

How to Use This Manual

To receive the maximum benefit from your 105 product, please read the **Introduction**, **Installation** and **Operation** chapters of this manual thoroughly before putting the 105 to work.

Chapter Four **Configuration** explains how to configure the modules using the Configuration Software available.

Chapter Five **Specifications** details the features of the product and lists the standards to which the product is approved.

Chapter Six **Troubleshooting** will help if your system has problems and Chapter Seven specifies the **Warranty and Service** conditions.

The foldout sheet *105 Installation Guide* is an installation drawing appropriate for most applications.

Warning !

1. For 105U modules, a radio licence is not required in most countries, provided the module is installed using the antenna and equipment configuration described in the *105 Installation Guide*. Check with your local 105 distributor for further information on regulations.
2. For 105U modules, operation is authorised by the radio frequency regulatory authority in your country on a non-protection basis. Although all care is taken in the design of these units, there is no responsibility taken for sources of external interference. The 105 intelligent communications protocol aims to correct communication errors due to interference and to retransmit the required output conditions regularly. However some delay in the operation of outputs may occur during periods of interference. Systems should be designed to be tolerant of these delays.
3. To avoid the risk of electrocution, the antenna, antenna cable, serial cables and all terminals of the 105 module should be electrically protected. To provide maximum surge and lightning protection, the module should be connected to a suitable earth and the antenna, antenna cable, serial cables and the module should be installed as recommended in the Installation Guide.
4. To avoid accidents during maintenance or adjustment of remotely controlled equipment, all equipment should be first disconnected from the 105 module during these adjustments. Equipment should carry clear markings to indicate remote or automatic operation. E.g. "This equipment is remotely controlled and may start without warning. Isolate at the switchboard before attempting adjustments."
5. The 105 module is not suitable for use in explosive environments without additional protection.

Caution!

For continued protection against risk of fire, replace the internal fuse only with the same type and rating.

CONTENTS

CHAPTER ONE INTRODUCTION	6
1.1 GENERAL	6
CHAPTER TWO INSTALLATION	9
2.1 GENERAL	9
2.2 ANTENNA INSTALLATION (<i>105U UNITS ONLY</i>)	9
2.2.1 <i>Dipole antenna.</i>	11
2.2.3 <i>Collinear antenna.</i>	12
2.3 POWER SUPPLY	13
2.3.1 <i>AC Supply</i>	13
2.3.2 <i>DC Supply</i>	13
2.3.3 <i>Solar Supply</i>	14
2.3.4 <i>Multiple Modules</i>	15
2.3.5 <i>24V Regulated Supply</i>	15
2.4 INPUT / OUTPUT	16
2.4.1 <i>Digital Inputs (105-1, 105-2 and 105-4)</i>	16
2.4.2 <i>Digital Outputs (105-1)</i>	16
2.4.3 <i>Digital Outputs (105-2, 105-3 and 105-4)</i>	17
2.4.4 <i>Analogue Inputs (105-1 and 105-2)</i>	18
2.4.5 <i>Analogue Outputs (105-1 and 105-3)</i>	18
2.4.6 <i>Pulse Input (105-1)</i>	19
2.4.7 <i>Pulse Inputs (105-2 and 105-4)</i>	19
2.4.8 <i>Pulse Output (105-1)</i>	20
2.4.9 <i>Pulse Output (105-3 and 105-4)</i>	20
2.4.10 <i>RS232 Serial Port</i>	21
2.4.11 <i>RS485 Serial Port</i>	22
2.4.12 <i>Connecting 105S Modules to 105U Modules</i>	22
CHAPTER THREE OPERATION	23
3.1 POWER-UP AND NORMAL OPERATION	23
3.1.1 <i>Communications</i>	23
3.1.2 <i>Change of state conditions</i>	25
3.1.3 <i>Analogue Set-points</i>	27
3.1.4 <i>Start-up Poll</i>	28
3.1.5 <i>Communications Failure (CF)</i>	28
3.1.6 <i>Resetting Outputs</i>	28
3.2 SYSTEM DESIGN TIPS	28
3.2.1 <i>System Dynamics</i>	29
3.2.2 <i>Radio Channel Capacity</i>	29
3.2.3 <i>Radio Path Reliability</i>	29
3.2.4 <i>Design for Failures</i>	30
3.2.5 <i>Indicating a Communications Problem</i>	30
3.2.6 <i>Testing and Commissioning</i>	31

CHAPTER FOUR CONFIGURATION	32
4.1 INTRODUCTION	32
4.2 EASY CONFIGURATION USING DEFAULT SETTINGS	33
4.3 105 CONFIGURATION SOFTWARE	35
4.3.1 <i>Hardware and Software Requirements</i>	35
4.3.2 <i>Programme Operation</i>	36
4.3.3 <i>Loading Configuration from a Module</i>	47
4.3.4 <i>Print Options</i>	47
4.3.5 <i>Using 105S Modules</i>	47
CHAPTER FIVE SPECIFICATIONS	50
CHAPTER SIX TROUBLESHOOTING	54
6.1 DIAGNOSTICS CHART	54
6.2 SELF TEST FUNCTIONS	54
6.2.1 <i>Input to Output Reflection (105-1 only)</i>	54
6.2.2 <i>Radio Testing using Tone Reversals</i>	55
6.2.3 <i>Diagnostics menu</i>	55
CHAPTER SEVEN WARRANTY & SERVICE	61
APPENDIX A SYSTEM EXAMPLE	62
APPENDIX B TERMINAL LAYOUTS	68

Chapter One

INTRODUCTION

1.1

General

The 105 range of telemetry modules has been designed to provide standard “off-the-shelf” telemetry functions, for an economical price. *Telemetry* is the transmission of signals over a long distance via a medium such as radio or twisted-pair wire. Although the 105 is intended to be simple in its application, it also provides many sophisticated features. This manual should be read carefully to ensure that the modules are configured and installed to give reliable performance.

The unit can monitor and control the following types of signals:

Digital on/off signals

Example outputs - motor run, siren on

Example inputs - motor fault, tank overflow, intruder alarm

Analogue continuously variable signals (0-20mA)

Example outputs - tank level indication, required motor speed

Example inputs - measured tank level, actual motor speed

Pulse frequency signals

Examples - electricity metering, fluid flow

Internal Status signals

Examples - analogue battery voltage, power status, solar panel status and low battery status.

The unit will monitor the input signals and transmit the signal information by radio or RS485 twisted pair to another 105 module. At the remote unit, the signals will be reproduced as digital, analogue or pulse output signals. The 105 also provides analogue set points, so that a digital output may be configured to turn on and off depending on the value of an analogue input. The pulse I/O transmits an accumulated value and the pulses are reliably recreated at the remote unit regardless of ‘missed’ transmissions. The actual pulse rate is also calculated and is available as a remote analogue output.

This manual covers the 105U and 105S modules. We have provided a summary on all products available in the 105 telemetry range, below.

- **105U-1, 105U-2, 105U-3 and 105U-4** modules have UHF radio **and** serial communications. The modules differ only in their input/output (I/O) design, and are compatible, i.e. they can be used to communicate signals to each other in the same network.
- **105S-1, 105S-2, 105S-3 and 105S-4** modules have **only** serial communications. All other specifications are as per the 105U-1, 2, 3 & 4 modules. The 105S modules are compatible with 105U modules.

- The **105U-C** module provides an interface between host devices such as PLC's or SCADA computers, and a radio telemetry system comprising 105U and 505U radio telemetry modules. The 105U-C allows 105U/505U modules to act as remote wireless I/O for the host devices. For more information, refer to the **105U-C User Manual**.

Product naming convention:

1 0 5 a – x where a is:

U = UHF radio + RS232/RS485 serial S = RS232/RS485 serial only

and x is:

1 = Input / Output module 2 = Input module (includes one output) 3 = Output module

4 = Input / Output module

C= Interface module

	105U-1	105S-1	105U-2	105S-2	105U-3	105S-3	105U-4	105S-4
Radio	✓		✓		✓		✓	
Serial	✓	✓	✓	✓	✓	✓	✓	✓
Digital Inputs (DI)	4		4				4 to 16	
Digital Outputs (DO)	4 (relay)		1 (FET)		8 (FET)		4 to 16 (FET)	
Analogue Inputs (AI)	2 (4-20mA)		6 (0-20mA)					
Analogue Outputs (AO)	2 (4-20mA)				8 (0-20mA)			
Pulse Inputs (PI)	1 (100Hz)		4 (1x1KHz, 3x100Hz)				4 (1x1KHz, 3x100Hz)	
Pulse Outputs (PO)	1 (100Hz)				4 (100 Hz)		4 (100 Hz)	
Comments	PI is DI 1. PO is separate to DO.		PI's are the same as DI's.		PO's are the same as DO's .		PI/ PO's are the same as DI/ DO's.	

Note regarding 105-4 modules. The 105-4 has a total of 20 digital I/O. Four are fixed inputs (also PI's) and four are fixed outputs (also PO's). The other 12 are selectable individually as DI or DO. The I/O range can vary from 16DI + 4DO to 4DI + 16DO or any combination in between.

All modules include power supply, microprocessor controller, input/output circuits, RS485/232 serial port, and a UHF radio transceiver - no external electronics are required. The 105U version has both radio and serial port communications. The 105S version does not

have a radio and has only serial communications. The 105U radio frequency has been selected to meet the requirements of unlicensed operation for remote monitoring and control of equipment. That is, a radio licence is not required for the 105 modules in many countries. See Chapter Five **Specifications** for details.

Input signals connected to a 105 module are transmitted to another 105 module and appear as output signals. These input signals may also be configured to appear as “inverted” signals on the output. A transmission occurs whenever a "change-of-state" occurs on an input signal. A "change-of-state" of a digital or digital internal input is a change from "off" to "on" or vice-versa. A "change-of-state" for an analogue input, internal analogue input or pulse input rate is a change in value of the signal of 3% (configurable from 0.8 to 50 %).

In addition to change-of-state messages, update messages are automatically transmitted on a regular basis. The time period may be configured by the user for each input. This update ensures the integrity of the system.

Pulse inputs are accumulated as a pulse count and the accumulated pulse count is transmitted regularly according to the configured update time.

The 105 modules transmit the input/output data as a data frame using radio or serial RS485 as the communications medium. The data frame includes the "address" of the transmitting 105 module and the receiving 105 module, so that each transmitted message is acted on only by the correct receiving unit. Each transmitted message also includes error checking to ensure that no corruption of the data frame has occurred due to noise or interference. The 105 module with the correct receiving "address" will acknowledge the message with a return transmission. If the original module does not receive a correct acknowledgement to a transmission, it will retry up to five times before setting the communications fail status of that path. In critical paths, this status can be reflected on an output on the module for alert purposes. The module will continue to try to establish communications and retry, if required, each time an update or change-of-state occurs.

A 105 telemetry system may be a complex network or a simple pair of modules. An easy-to-use configuration procedure allows the user to specify any output destination for each input.

The maximum number of modules in one system is 95 modules communicating by radio. Each of these modules may have up to 31 other modules connected by RS485 twisted pair. Modules may communicate by radio only, by RS485 only or by both RS485 and radio. Any input signal at any module may be configured to appear at any output on any module in the entire system.

Modules can be used as repeaters to re-transmit messages on to the destination module. Repeaters can repeat messages on the radio channel, or from the radio channel to the serial channel (and serial to radio). Up to five repeater addresses may be configured for each input-to-output link.

The units may be configured by using a PC connected to the RS232 port. The default configuration is defined in Section 4.2 **Easy Configuration Using Default Settings**, and software configuration is defined in Section 4.2 **105 Configuration Software**.

Chapter Two

INSTALLATION

2.1

General

The 105 module is housed in a rugged aluminium case, suitable for DIN-rail mounting. Terminals are suitable for cables up to 2.5 sqmm in size.

Normal 110/220/240V mains supply should not be connected to any input terminal of the 105 module. Refer to Section 2.3 **Power Supply**.

Before installing a new system, it is preferable to bench test the complete system. Configuration problems are easier to recognise when the system units are adjacent. Following installation, the most common problem is poor communications on the radio channel or the serial channel. For radio modules, problems are caused by incorrectly installed antennas, or radio interference on the same channel, or the radio path being inadequate. If the radio path is a problem (i.e. path too long, or obstructions in the way), then higher performance antennas or a higher mounting point for the antenna may fix the problem. Alternately, use an intermediate 105 module as a repeater.

For serial modules, poorly installed serial cable, or interference on the serial cable is a common problem.

The foldout sheet 105 Installation Guide provides an installation drawing appropriate to most applications. Refer to Appendix B of this manual for terminal layout drawings of the modules.

Each 105 module should be effectively earthed via a "GND" terminal on the 105 module - this is to ensure that the surge protection circuits inside the 105 module are effective.

2.2

Antenna Installation *(105U units only)*

The 105 module will operate reliably over large distances. The distance which may be reliably achieved will vary with each application - depending on the type and location of antennas, the degree of radio interference, and obstructions (such as hills or trees) to the radio path. Please refer to your distributor for the expected maximum distance to comply with local radio regulations. Where it is not possible to achieve reliable communications between two 105 modules, then a third 105 module may be used to receive the message and re-transmit it. This module is referred to as a repeater. This module may also have input/output (I/O) signals connected to it and form part of the I/O network - refer to Chapter 4 **Configuration** of this manual.

An antenna must be connected to each 105 module using the coaxial female connector which protrudes through one of the end plates.

To achieve the maximum transmission distance, the antennas should be raised above intermediate obstructions so the radio path is true "line of sight". Because of the curvature of the earth, the antennas will need to be elevated at least 5 metres above ground for paths greater than 5 km (3 miles). For short

distances, the modules will operate reliably with some obstruction of the radio path. Obstructions which are close to either antenna will have more of a blocking affect than obstructions in the middle of the radio path. For example, a group of trees around the antenna is a larger obstruction than a group of trees 100 metres from the antenna.

An antenna should be connected to the module via 50 ohm coaxial cable (eg RG58 or RG213) terminated with a male coaxial connector. The higher the antenna is mounted, the greater the transmission range will be, however as the length of coaxial cable increases so do cable losses. For use on unlicensed frequency channels, there are several types of antennas suitable for use. It is important antenna are chosen carefully to avoid contravening the maximum power limit on the unlicensed channel - normally the net gain of the antenna/cable configuration should be no more than 2dB.

The net gain of an antenna/cable configuration is the gain of the antenna (in dBi) less the loss in the coaxial cable (in dB).

The gains and losses of typical antennas are

Antenna	Gain (dB)	
Dipole with integral 3m cable	0	
Dipole without cable	2	
5dBi Collinear(3dBd)	5	
8dBi Collinear (6dBd)	8	
3 element Yagi	5	
6 element Yagi	10	
Cable type	Loss (dB per 10 m)	
	400-500MHz	869MHz
RG58	-3	-5
RG213	-1.5	-2.5
Cellfoil	-1.5	-3

The net gain of the antenna/cable configuration is determined by adding the antenna gain and the cable loss. For example, a 3 element Yagi with 15 metres of RG58 has a net gain of 0.5dB (5dB – 4.5dB) at 450MHz.

Connections between the antenna and coaxial cable should be carefully taped to prevent ingress of moisture. Moisture ingress in the coaxial cable is a common cause for problems with radio systems, as it greatly increases the radio losses. We recommend that the connection be taped, firstly with a layer of PVC Tape, then with a vulcanising tape such as “3M 23 tape”, and finally with another layer of PVC UV Stabilised insulating tape. The first layer of tape allows the joint to be easily inspected when trouble shooting as the vulcanising seal can be easily removed.

Where antennas are mounted on elevated masts, the masts should be effectively earthed to avoid lightning surges. The 220MHz and 400 – 500MHz radios are fitted with surge protection, however the 868MHz radio does not. For high lightning risk areas, additional surge suppression devices are

recommended. If the antenna is not already shielded from lightning strike by an adjacent earthed structure, a lightning rod may be installed above the antenna to provide shielding.

2.2.1 Dipole antenna.

A unity gain dipole is the normal antenna for use on unlicensed channels. As it does not provide any gain, then the power transmitted from the antenna will be the same as the power out of the module, and hence will not exceed the permitted power of the unlicensed channel.

Dipole antennas should be mounted vertically, at least 1 metre away from a wall or mast for maximum performance.

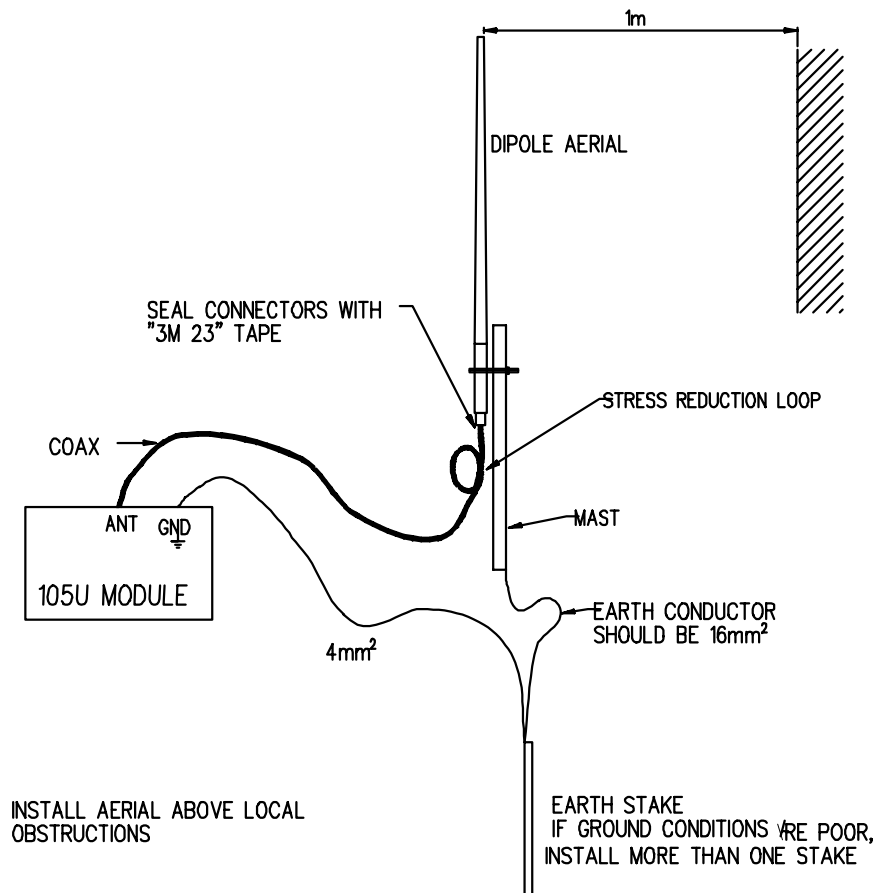

2.2.2 Yagi antenna.

Yagi antennas are directional. That is, they have positive gain to the front of the antenna, but negative gain in other directions. This may be used to compensate for coaxial cable loss for installations with marginal radio path.

Yagi antennas should be installed with the central beam horizontal and must be pointed exactly in the direction of transmission to benefit from the gain of the antenna. Also note that Yagi antennas normally have a drain hole on the folded element - the drain hole should be located on the bottom of of

the installed antenna.

The Yagi antennas may be installed with the elements in a vertical plane (vertically polarised) or in a horizontal plane (horizontally polarised). For a two station installation, with both modules using Yagi antennas, horizontal polarisation is recommended. If there are more than two stations transmitting to a

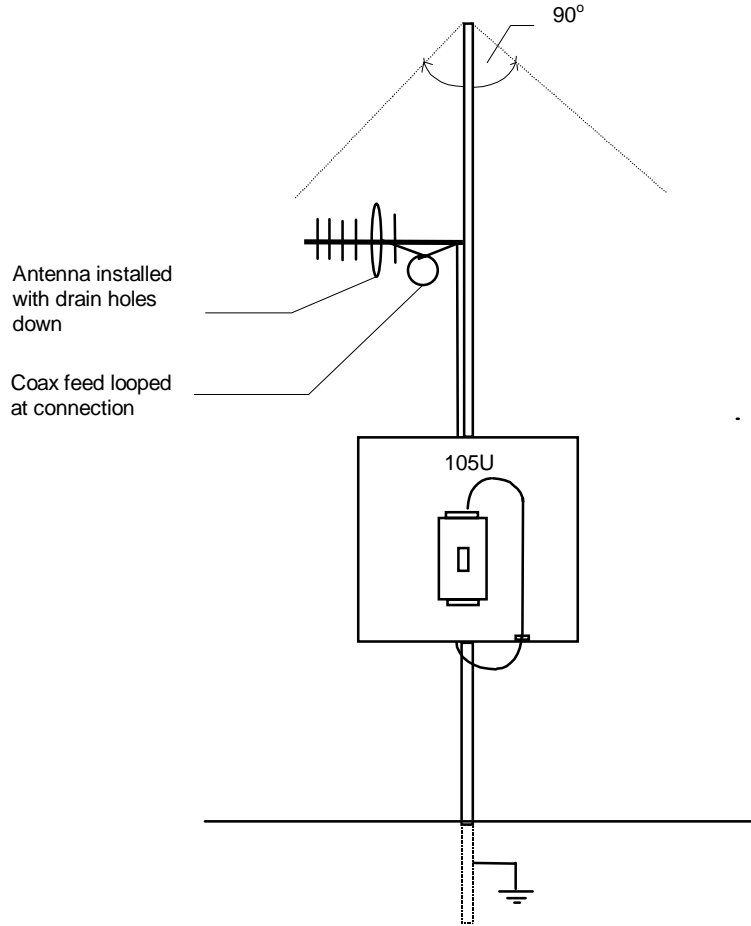

common station, then the Yagi antennas should have vertical polarisation, and the common (or “central” station should have a dipole or collinear (non-directional) antenna.

2.2.3 Collinear antenna.

A collinear antenna may be used in the same way as a 3 element Yagi to compensate for the losses in long lengths of coaxial cable. This type of antenna is generally used at a central site with more than one remote site or at a repeater site. The collinear antenna looks similar to the dipole, except that it is longer.

2.3

Power Supply

The 105 power supply is a switch-mode design which will accept either AC or DC supply. The 105 module may also be powered from a solar panel without an external solar regulator.

The 105 module accepts supply voltages in the following ranges :

12 - 24 volts AC RMS or 15 - 30 volts DC at the "supply" terminals, or
 10.8 - 15 volts DC at the "battery" terminals.

The power supply should have a minimum capacity of 9 Watts..

2.3.1 AC Supply

The AC supply is connected to the "SUP1" and "SUP2" terminals as shown below.

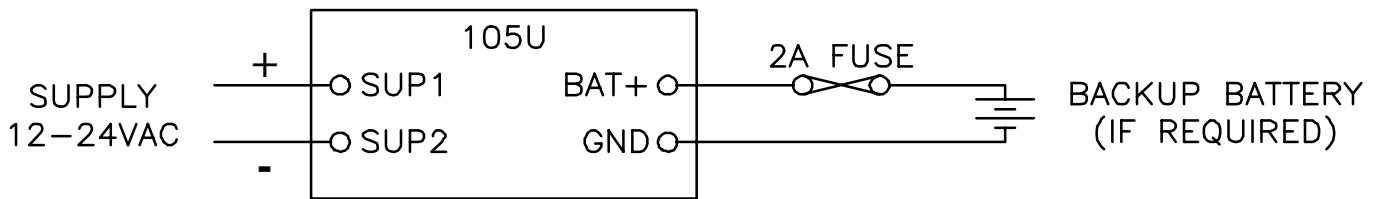

The AC supply should be "floating" relative to earth. A 220-240/16 VAC mains "plug-pack" is available for mains applications.

2.3.2 DC Supply

For DC supplies, the positive lead is connected to "SUP1" and the negative to "GND". The positive side of the supply **must not be connected to earth**. The DC supply may be a floating supply or negatively grounded.

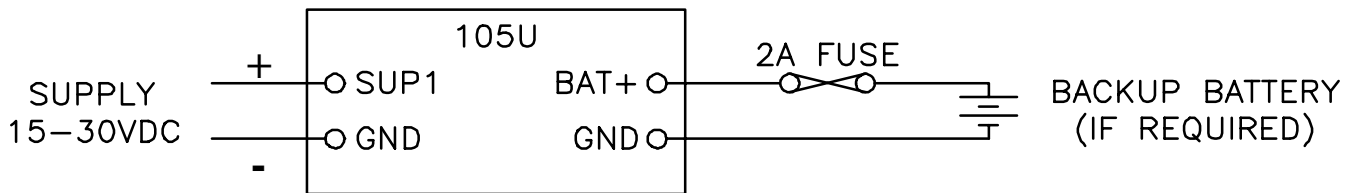

The 105 module may also be powered from an external 11 - 15 VDC battery supply without the need for a "normal" supply connected to "SUP1". This external battery supply is connected to "BAT+" and "GND" terminals. The positive lead of the external supply should be protected by a 2A fuse.

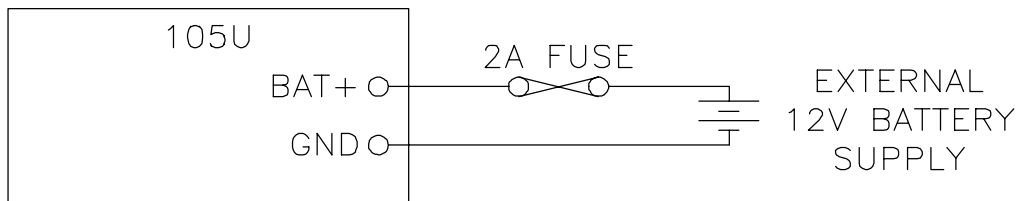

Upon failure of the normal supply, the 105 module may continue to operate for several hours from a backup battery. The 105 module includes battery charging circuits for charging up to a 12 AHr sealed lead acid battery. The battery is connected to the "BAT+" (positive) and "GND" (negative) terminals. The positive lead from the battery should be protected with a 2A fuse, installed as near to the battery terminal as possible. On return of main supply, the unit will switch back to mains operation, and recharge the battery. To provide adequate current to recharge the backup battery, an AC supply of 15V minimum or a DC supply of 17V minimum must be used. Typically, a 6 AHr battery will supply the 105 for 1 - 3 days, depending on I/O loads.

2.3.3 Solar Supply

The 105 power supply also includes a 12 V solar regulator for connecting 12V solar panels of up to 30W, and solar batteries of up to 100AHr. **The unit must not be powered from a solar panel without a battery.** An 18W solar panel is sufficient for most solar applications. The size of the solar battery required depends on the I/O used. Batteries are sized for a number of sunless days with 50% battery capacity remaining as follows:

$$\text{No. of sunless days} = \frac{\text{Battery capacity (AHr)} \times 0.5}{\text{Module load (A)} \times 1.2 \times 24}$$

The Module load depends on the I/O connected and can be calculated as follows:

$$\text{Module Load(A)} = 0.07 + (0.01 \times \text{No. of DI's}) + (0.025 \times \text{No. of DO's}) + (2 \times \text{Analogue loop load}).$$

The analogue loop load is the total signal current for the AI's and AO's which are powered from the internal 24V supply. Externally powered loops are not included in this.

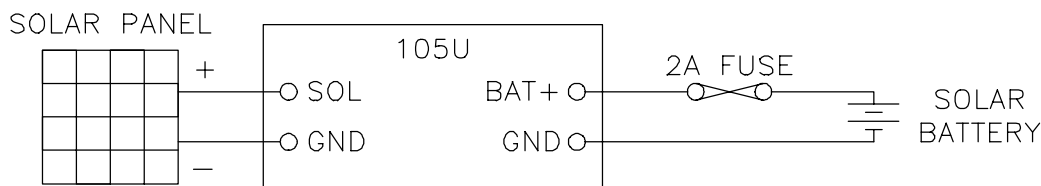

The solar panel is connected to the "SOL" (positive) and "GND" (negative) terminals and the battery connected to the "BAT+" (positive) and "GND" (negative) terminals. Solar panels must be installed and connected as per the panel manufacturer's instructions. The positive lead of the battery should be protected by a 2A fuse installed as near as possible to the battery terminal.

Where a panel larger than 30W is required, an external solar regulator should be used.

For maintenance, disconnect the solar panel first before disconnecting the battery.

2.3.4 Multiple Modules

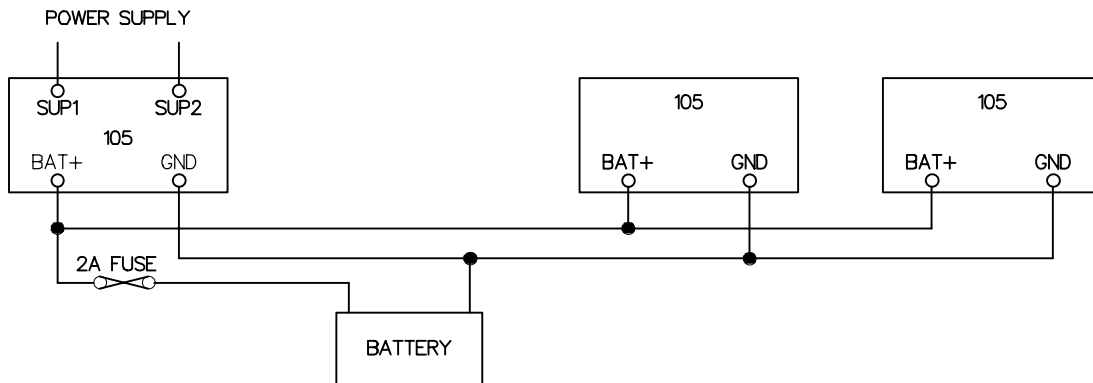

Where more than one module is installed at the one location, a shared power supply and battery may be used, provided the total load does not exceed the power supply.

The internal power supply of the 105 module can supply a maximum 12V load of 700mA. In order to achieve this, the input power supply must be above 15VAC or 17VDC. Using these figures, it can be determined whether there is enough supply for more than one module - allow 100mA for recharging a battery.

For example, assume there is a 105U-01 module and a 105S-01 module at the same location. The total I/O at the location is 3 analogue inputs, 6 digital inputs and 4 digital outputs. The total load will be :-

TYPE OF LOAD	LOAD mA
105U-01 quiescent	70
105S-01 quiescent	45
6 DI @ 10 mA	60
3 AI @ 20mA x 2	120
4 DO @ 25mA	100
Battery charging	100
TOTAL	495

So both modules could be powered from one power supply and one battery, provided the external supply voltage is more than 15VAC or 17VDC.

2.3.5 24V Regulated Supply

Each 105 module provides a 24V DC regulated supply for analogue loop power, except for 105-4. The supply is rated at 150mA, and should **only be used for analogue loops**.

2.4

Input / Output

2.4.1 Digital Inputs (105-1, 105-2 and 105-4)

The 105-1 and 105-2 modules each provide four digital inputs with 5000 volt opto-isolation, and the 105-4 provides 4 – 16 inputs with 3000 volt surge protection. All inputs are suitable for voltage free contacts (such as mechanical switches) or NPN transistor devices (such as electronic proximity switches). PNP transistor devices are not suitable. Contact wetting current of approximately 5mA is provided to maintain reliable operation of driving relays.

Each digital input is connected between the appropriate "DI" terminal and common "COM". Each digital input circuit includes a LED indicator which is lit when the digital input is active, that is, when the input circuit is closed. Provided the resistance of the switching device is less than 200 ohms, the device will be able to activate the digital input.

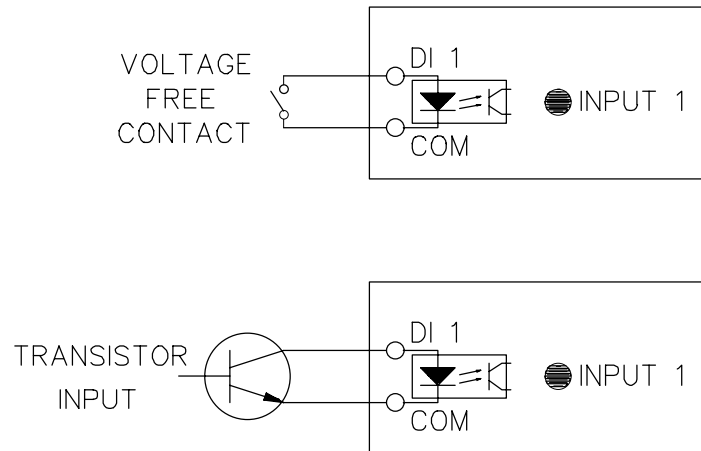

For pulse inputs, refer to Section 2.4.6.

2.4.2 Digital Outputs (105-1)

The 105-1 module provides four normally open voltage-free relay contacts, rated at AC3 250V/2A, 120V/5A ; AC1 - 250V/5A ; DC - 30V/2A, 20V/5A. These outputs may be used to directly control low-powered equipment, or to power larger relays for higher powered equipment. When driving inductive loads such as AC relays, good installation should include capacitors (e.g. 10nf 250V) across the external circuit to prevent arcing across the relay contacts. For DC inductive loads, flyback diodes should be used to drive DC relays.

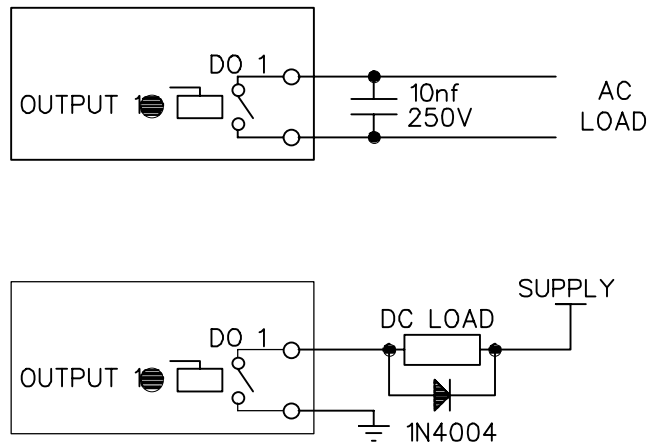

Digital outputs may be configured to individually turn off if no command message is received to that output for a certain period. This feature provides an intelligent watch dog for each output, so that a communications failure at a transmitting site causes the output to revert to a known state. See section 4.4 **Changing User Options** for further details.

The output circuit is connected to the appropriate pair of "DO" terminals. Each digital output circuit includes a LED indicator which is lit when the digital output is active.

2.4.3 Digital Outputs (105-2, 105-3 and 105-4)

The digital outputs on the 105-2, 105-3 and 105-4 modules are transistor switched DC signals, FET output to common rated at 30VDC 500 mA. The 105-2 provides one digital output; the 105-3 provides eight digital outputs and the 105-4 provides 4 – 16 outputs. The first four DO's on the 105-3 and 105-4 modules are also the pulse outputs - that is, the first four DO's can be either digital outputs or pulse outputs. The function of each of these outputs may be configured individually. For a description of pulse outputs, refer to Section 2.4.7.

Digital outputs may be configured to individually turn off if no command message is received to that output for a certain period. This feature provides an intelligent watch dog for each output, so that a communications failure at a transmitting site causes the output to revert to a known state. See Chapter 4 **Configuration** for further details.

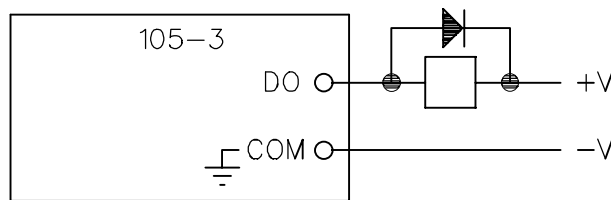

The output circuit is connected to the appropriate pair of "DO" terminals. Each digital output circuit includes a LED indicator which is lit when the digital output is active.

2.4.4 Analogue Inputs (105-1 and 105-2)

The 105-1 module provides two 4 - 20 mA DC analogue inputs for connecting to instrument transducers such as level, moisture, pressure transducers, etc. The 105-2 module provides six 0 - 20 mA DC analogue inputs. Note that the inputs on the 105-2 module will measure down to 0mA, so they can also be used for zero based signals such as 0 - 10 mA.

Each analogue input has a positive and negative terminal, and may be placed at any point in the current loop, as long as neither input rises above the 24 volt supply level. Each input has a loop resistance of less than 250 ohms and zener diode protection is provided against over-voltage and reverse voltage, however additional protection may be required in high voltage or noisy environments.

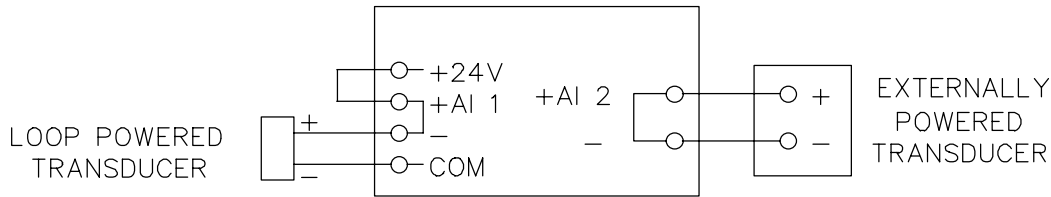

A 24VDC supply is available on the 105 module for powering the analogue transducer loops. In this case, the analogue loop should be connected between a "AI 1-" terminal and "COM" (for the first analogue input) or "AI 2-" (for the second analogue input), and so on for other inputs. The positive terminal ("AI 1+" or "AI 2+", etc) should be connected to "+24V".

Externally powered loops may be connected by connecting the input between "AI 1+" and "AI 1-" for analogue input 1 or "AI 2+" and "AI 2-" for analogue input 2, and so on for other inputs. Analogue Input 1 "AI 1+" may also be configured to control a high/low analogue set-point. See Chapter 4 **Configuration** for further details.

Common mode voltage may be -0.5V to 27V. Shielded cable is recommended for analogue I/O loops to minimise induced noise and Radio Frequency Interference (RFI). The shield of the cable should be connected to earth at one of the cable only. The use of shielded wiring inside an enclosure containing a 105 module is also recommended.

2.4.5 Analogue Outputs (105-1 and 105-3)

The 105-1 module provides two 4 - 20 mA DC analogue outputs for connecting to instrument indicators for the display of remote analogue measurements. The 105-3 module provides eight 0 - 20 mA DC analogue outputs. Each analogue output is a "sink" to common.

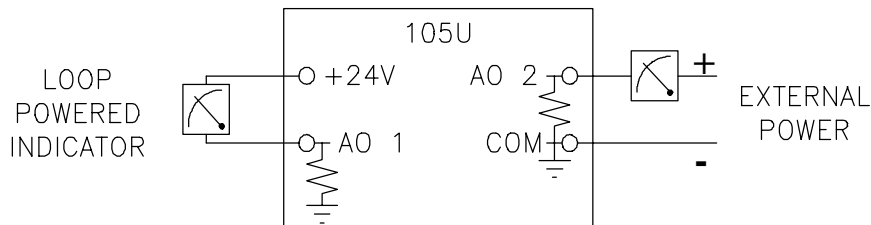

A 24VDC supply is available on the 105 module for powering the analogue output loop (max external loop resistance 1000 ohms). In this case, the analogue loop is connected between a "+24V" terminal and "AO 1" (for the first analogue output) or "AO 2" (for the second analogue output), and so on for the other output signals.

Externally powered loops to 27 VDC may be connected by connecting the output between the "AO" terminal (positive) and the "COM" terminal (negative). Zener protection of analogue outputs provides protection against short periods of over-voltage but longer periods **may result in module damage**. Note that the 105 common is connected internally to ground and no other point in the analogue loop should be grounded.

Analogue outputs may also be configured to individually turn off (0 mA) if no command message is received to that output for a certain period. . See Chapter 4 **Configuration** for further details.

2.4.6 Pulse Input (105-1)

For the 105-1 module, digital input 1 may be configured as a pulse input (max rate 100 Hz, min. off time 5 ms). In this mode, both the pulse **rate** and the pulse **count** are available for mapping to a remote output. The pulse rate may appear at any analogue output on the remote unit, while the pulse count can appear at a Pulse Output on another 105-1 or Digital Output on a 105-3 unit. The pulse input should be connected in the same way as a digital input.

2.4.7 Pulse Inputs (105-2 and 105-4)

For the 105-2 and 105-4 modules, the four digital inputs (DI 1-4) may be configured as pulse inputs. The first digital/pulse input DI 1 has a maximum rate of 1000 Hz (min. off time 0.5 ms), while DI 2-4 have a maximum rate of 100 Hz (min. off time 5 ms). When using DI 1 at high pulse rates (more than 100 Hz), a divide by 10 function may be configured to reduce the pulse count at the output, as Pulse Outputs have a maximum rate of 100 Hz.

For each pulse input, both the pulse **rate** and the pulse **count** are available for mapping to a remote output. The pulse rate may appear at any analogue output on the remote unit, while the pulse count can appear at a Pulse Output. The default update time for pulse counts is 1 minute. This can be changed by changing the update time configuration - refer Chapter 4 **Configuration** for further details. The pulse count is a 16 bit value - "roll over" of the count when it exceeds the maximum value is automatically handled by the 105 modules.

Pulse inputs should be wired in the same way as digital inputs (see Section 2.4.1).

2.4.8 Pulse Output (105-1)

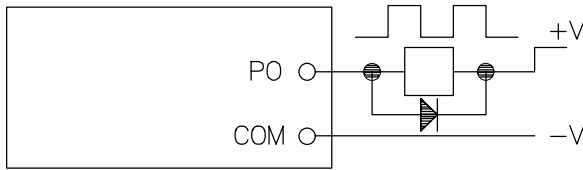

A single FET output to common rated at 30VDC, 500 mA is provide for the pulse output "PO". This output accurately recreates the pulses counted at a pulse input at a 105-1 or 105-2 module.

Although the count is accurately re-created, the rate of output pulses may not accurately reflect the input rate. The actual input pulse rate may be configured to appear at an analogue output if required. Note that the pulse rate and accumulated value will remain accurate even if a period of communications failure has occurred. The maximum output rate is 100 Hz. If a high speed pulse input is used (more than 100 Hz) on PI1 of a 105-2 module, the pulse input count should not be transmitted to a PO on the 105-1 or DO on the 105-3 without configuring the divide-by-10 function (on the 105-2 or 105-4 module)

2.4.9 Pulse Output (105-3 and 105-4)

The first four digital outputs on the 105-3 and 105-4 modules may also be used as pulse outputs. The outputs are FET output to common rated at 30VDC, 500 mA. The outputs will provide a pulse signal of up to 100 Hz. The outputs accurately recreate the pulses counted at pulse inputs at a 105-1, 105-2 or 105-4 module.

Although the count is accurately re-created, the rate of output pulses may not accurately reflect the input rate. The actual input pulse rate may be configured to appear at an analogue output if required. Note that the pulse rate and accumulated value will remain accurate even if a period of communications failure has occurred.

2.4.10 RS232 Serial Port

The serial port is a 9 pin DB9 female and provides for connection to a terminal or to a PC for configuration, field testing and for factory testing. This port is internally shared with the RS485 - ensure that the RS485 is disconnected before attempting to use the RS232 port. Communication is via standard RS-232 signals. The 105 is configured as DCE equipment with the pin-out detailed below. The serial port communicates at a baud rate of 9600 baud, 8 bits, no parity, one stop bit.

Pin	Name	Dirn	Function
1	DCD	Out	Data carrier detect - not used
2	RD	Out	Transmit Data - Serial Data Input (High = 0, Low = 1)
3	TD	In	Receive Data - Serial Data Output (High = 0, Low = 1)
4	DTR	In	Data Terminal Ready - not used
5	SG	-	Signal Ground
6	DSR	Out	Data Set Ready - not used
7	RTS	In	Request to Send - not used
8	CTS	Out	Clear to send - not used
9	RI	-	Ring indicator - not used.

An example cable drawing for connection to a laptop is detailed below:

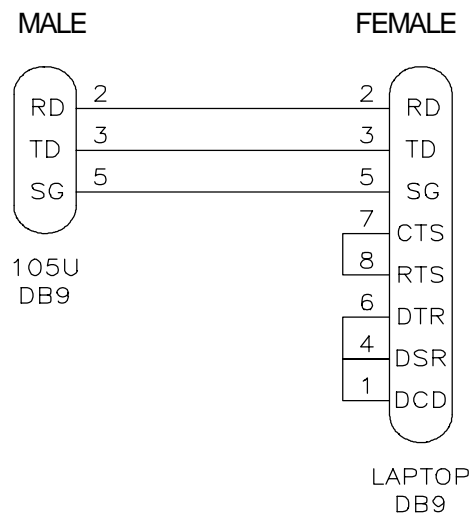

2.4.11 RS485 Serial Port

The RS485 port provides for communication between multiple 105 units using a multi-drop cable. Up to 32 units may be connected in each multi-drop network. Each multi-drop network may have one unit providing radio communications with other units in the system. The RS485 feature allows local hubs of control to operate without occupying radio bandwidth required for communication between remotely sited units.

The RS485 Communications format is 9600 baud, 8 data bits, one stop bit, no parity. Note that the RS485 port is shared internally with the RS232 port - disconnect the RS232 cable after configuration is complete.

RS485 is a balanced, differential standard but it is recommended that shielded, twisted pair cable be used to interconnect modules to reduce potential Radio Frequency Interference (RFI). An RS485 network should be wired as indicated in the diagram below and terminated at each end of the network with a 120 ohm resistor.

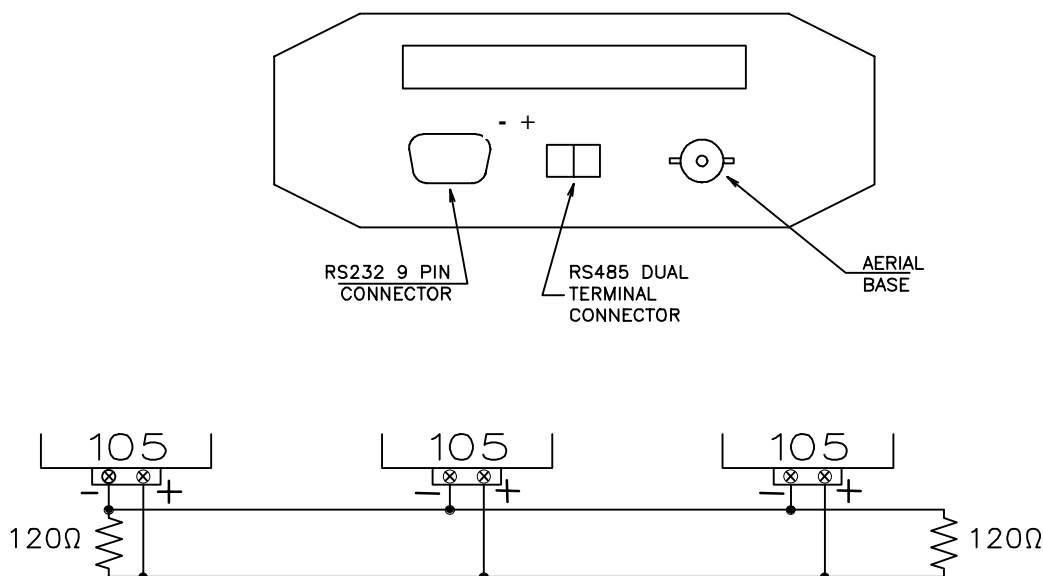

2.4.12 Connecting 105S Modules to 105U Modules

105S modules connect to a 105U via the RS485 port on each module - refer to section 2.4.11. Up to 31 x 105S modules can be connected to a 105U module. This number is reduced for 105S-3 and -4 modules, as these modules use two unit addresses (refer to chapter 4 of this manual).

The 105S modules can be mounted next to the 105U module, or they can be remote from the 105U. The reliable distance for a RS485 multi-drop line depends on the shielding of the wire and how close it is installed to electrical noise sources - distances of more than 1 km can be achieved by good installation methods.

Chapter Three

OPERATION

3.1 Power-up and Normal Operation

When power is initially connected to the 105 module, the module will perform internal diagnostics to check its functions. The following table details the status of the indicating LED's on the front panel under **normal** operating conditions.

LED Indicator	Condition	Meaning
OK	On	Normal Operation
RX	Occasional flash	Radio Receiving, or Activity on serial ports
RX	Flashes continuously	Configuration Mode
RX	On	Button press when entering Configuration Mode
TX (only on 105U units)	Occasional flash	Radio Transmitting
PWR	On	Supply voltage available from Solar Panel or SUP1/SUP2
OK	Flashes every 5 seconds	+24V Supply overloaded

Additional LED's provide indication of the status of digital inputs and outputs. LED's display the status of each digital input (lit for active), and LED's display the status of each digital output (lit for active). Other conditions indicating a fault are described in Chapter Six **Troubleshooting**.

The 105 module monitors the power supply and provides status of supply failure and battery low voltage for "mapping" to one of the module's own outputs or transmitting to a remote output. When the 105 module is powered from a normal supply (i.e. via either of the "SUP" terminals), the *PWR* LED indicator is lit. When the 105 modules is powered from a solar panel and battery, the *PWR* LED indicator is lit only when the charge current is available (i.e. when the solar panel is receiving light). In the event of excessively low battery voltage (10.8V), the *OK* LED will go off, the unit will automatically set all outputs off, and disable the +24V analogue loop supply. the *OK* LED will turn on again after the battery voltage exceeds 11.3V. This enables installations to be configured so that the battery current drain is minimised in the event of extended mains failure, reducing the possibility of deep discharge of batteries.

3.1.1 Communications

If transmissions are not successful, then the 105 module will re-try up to four times at random intervals to transmit the message. If communications is still not successful, the "Comms Fail" internal status will be set. In the default configuration, this will have no consequence and the

105 module will continue to attempt to transmit to the remote module every ten minutes. For critical applications, this status can be configured to be reflected to an output on the module for alert purposes. The outputs on the module may also be configured to reset after a specified timeout (digital outputs reset to “off”, analogue outputs reset to 0 mA) allowing the system to turn off in a controlled manner e.g. a pump will never be left running because of a system failure.

Example of Successful Communications

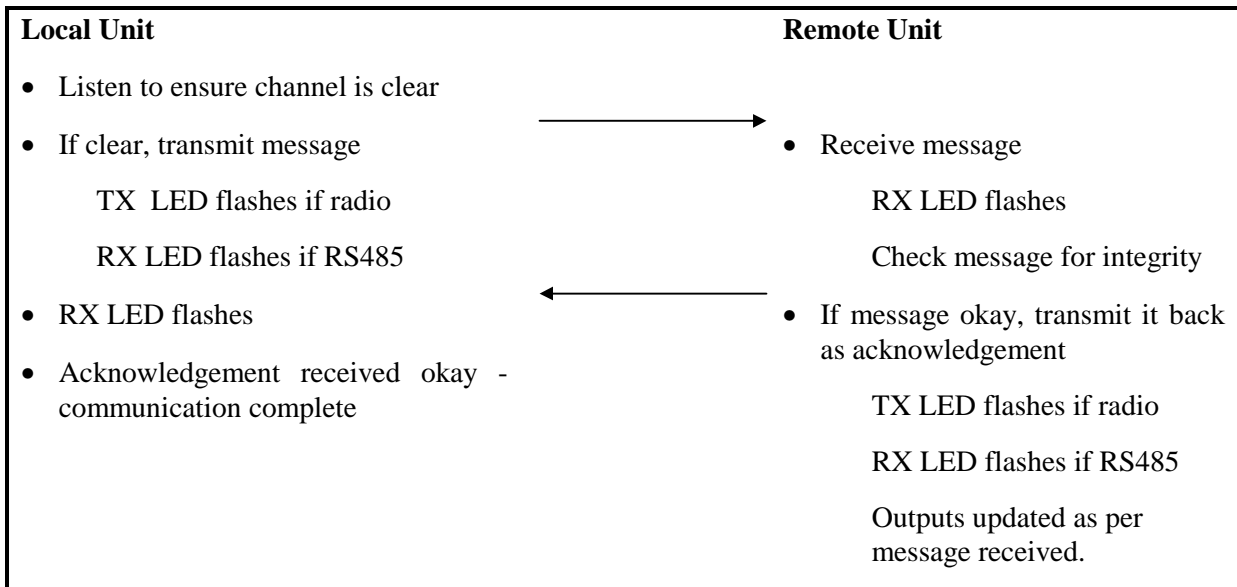

Example of unsuccessful communications

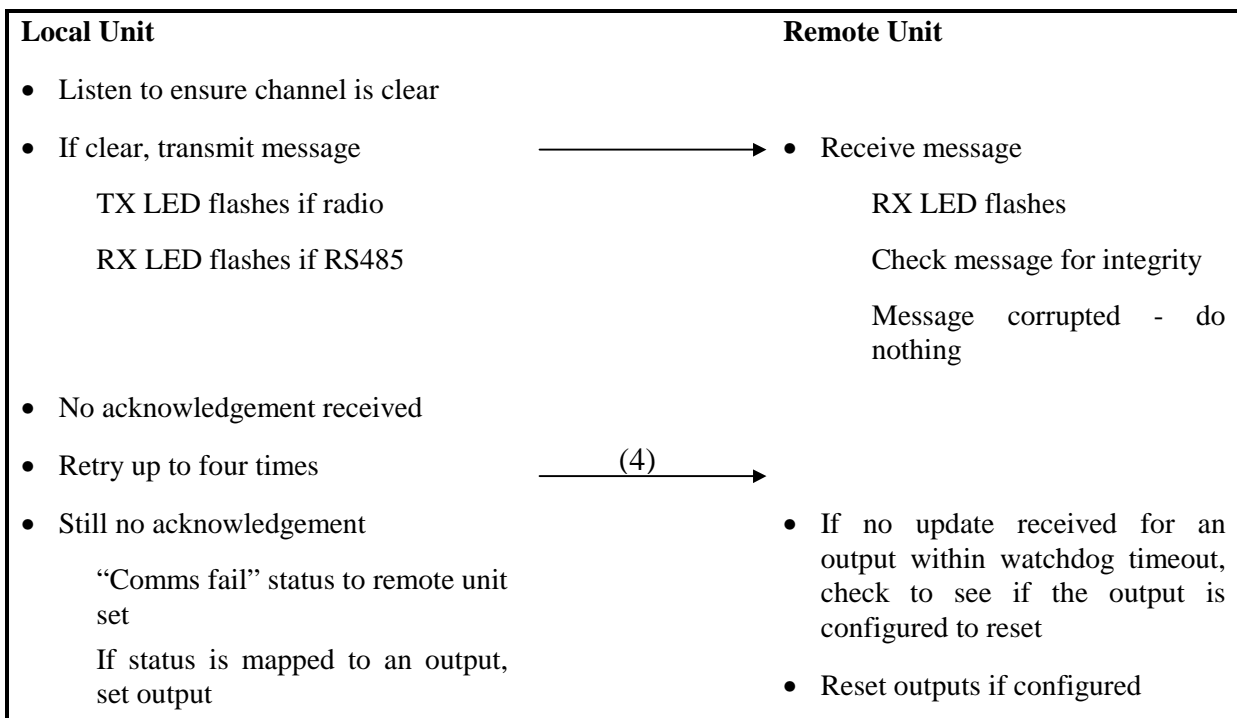

Repeaters can be used in a system to increase range. Each 105U unit can be configured to act as a repeater. When configuring an input to be mapped to an output, the communications path to the output unit, including the repeater addresses is specified. The 105U acts as a *digital repeater*, that is, the signal is decoded and then retransmitted “as new”.

Example Repeater Communications

Unit A DI 1 mapped to Unit D DO1 via Units B & C

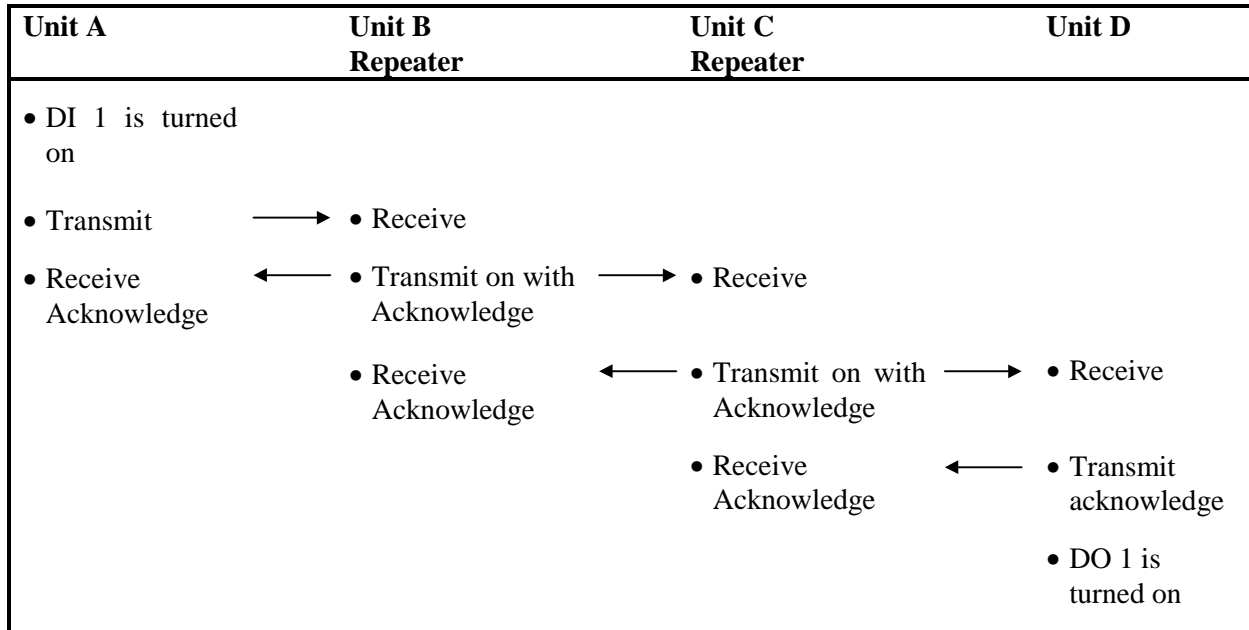

3.1.2 Change of state conditions

The 105 module transmits a data message whenever it detects a "change-of-state" on one of its input signals. A "change-of-state" of a digital or digital internal input is a change from "off" to "on" or vice-versa provided the change is sustained for 0.5 second (i.e. 0.5 second debounce). The debounce delay is configurable.

In addition to "change-of-state" transmissions, each module will transmit the status of each input to its corresponding output every ten minutes (configurable). These **updates** mean that the outputs are set to the current input values regularly, even where no “change-of-state” has occurred. These update transmissions increase the accuracy of the output and give extra system reliability. Update times can be configured from 10 seconds to 16 minutes on the 105-1, -2 and -3 modules, and from 10 seconds to 5 days on the 105-4. Note that the accuracy of the time period is approx 0.5%.

Analogue Change-of-state

A "change-of-state" for an analogue input, battery voltage or pulse input rate is a change in value of the signal of 3% (configurable) since the last transmission. Note that the sensitivity of 3% refers to 3% of the analogue range, not 3% of the instantaneous analogue value. That is, if an analogue input changes from 64% (14.24 mA) to 67% (14.72 mA), a "change-of-state" will be detected. This “change-of-state” sensitivity is configurable between 0.8% and 50%.

Analogue inputs are digitally filtered to prevent multiple transmissions on continually varying

or "noisy" signals. The input is filtered with a 1 second time constant and a 1 second debounce. The analogue outputs are filtered with a 1 second time constant. An example explaining the interaction of these figures is shown below. In general, the following may be used as a rule of thumb for calculating the appropriate sensitivity required for a given application:

Instantaneous change of 2 x sensitivity on input → 3 second output response

Instantaneous change of 10 x sensitivity on input → 5 second output response

The analogue inputs have 15 bit resolution and 0.016mA accuracy.

An **example** of an **analogue** input and how the output follows it is shown below:

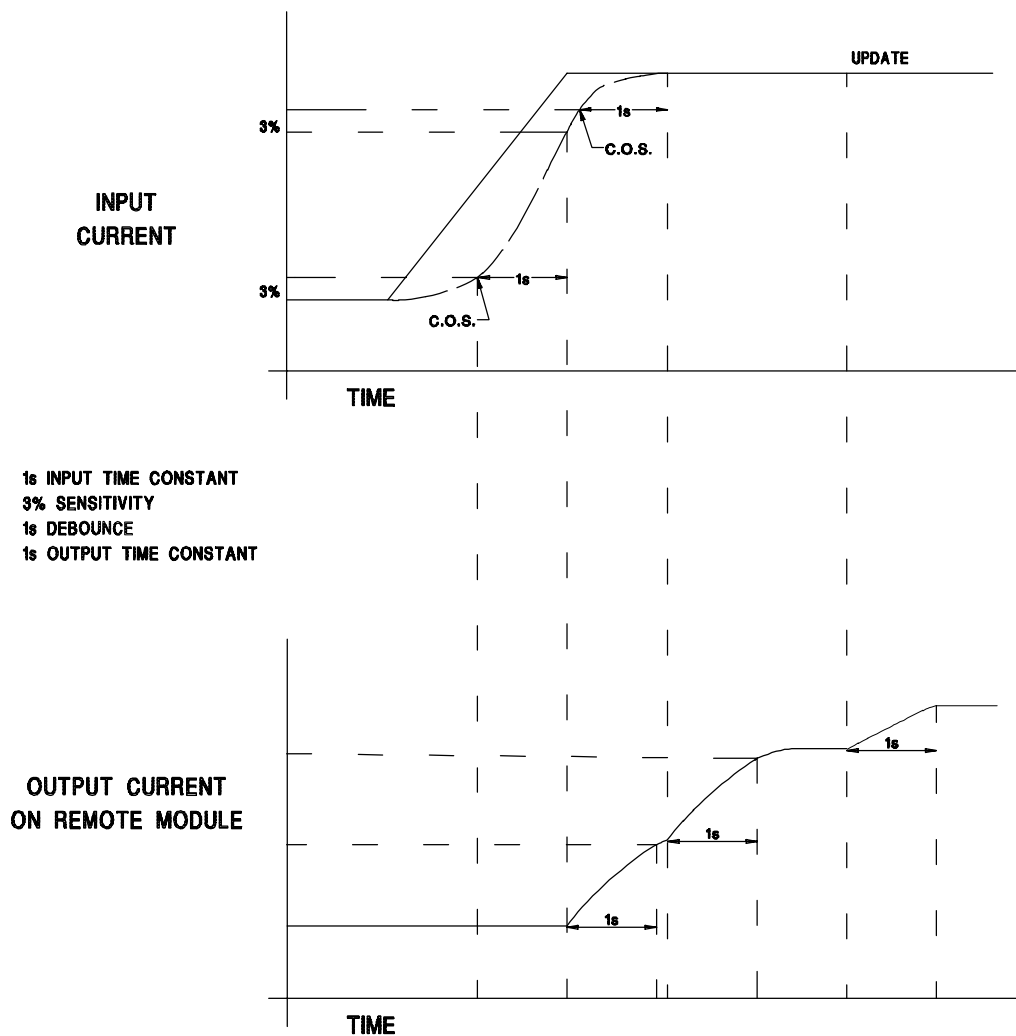

Pulse input change of state

Pulse input counts do not use “change-of-state” transmissions. Instead, accumulated pulse input counts are transmitted at set intervals. The default period is 1 minute and is configurable. The absolute pulse count is transmitted. If the PI is transmitted to a PO on a 105 module, then the pulse outputs are re-created from the *accumulated* pulse count. Rollovers of the pulse count thru zero are catered for. If a transmission is missed, the pulse output will still be re-created when the next accumulated value is transmitted. This ensures that no pulses are lost due to communications failures. If the PI is transmitted to a 105U-C

interface module, then the accumulated pulse count is stored in the 105U-C for interfacing to the host device.

The following diagram shows how pulse inputs are re-created as pulse outputs. For pulse outputs, the 105 module keeps two counters in memory - the pulse input count received from the remote 105 module, and the count of output pulses. When the 105 receives an update of the input pulse count, it will output pulses until the output pulse count is the same as the input pulse count. The output pulse will be output evenly over the pulse output update time which is configured in the module. For example, assume that 105 module receives a pulse input update message from the remote 105 module, and the difference between the pulse input count and the pulse output count is 12 pulses. The 105 will then output the 12 pulses evenly over the next minute (if the pulse output update time is 1 minute).

The default values for the pulse input update time and pulse output update time is 1 minute. In this case, the output pulses are effectively 1 minute behind the input pulses. These update times may be changed by the user. The pulse output update time should not be set to be more than the pulse input update time. Note that the maximum pulse rate for both inputs and outputs is 100Hz.

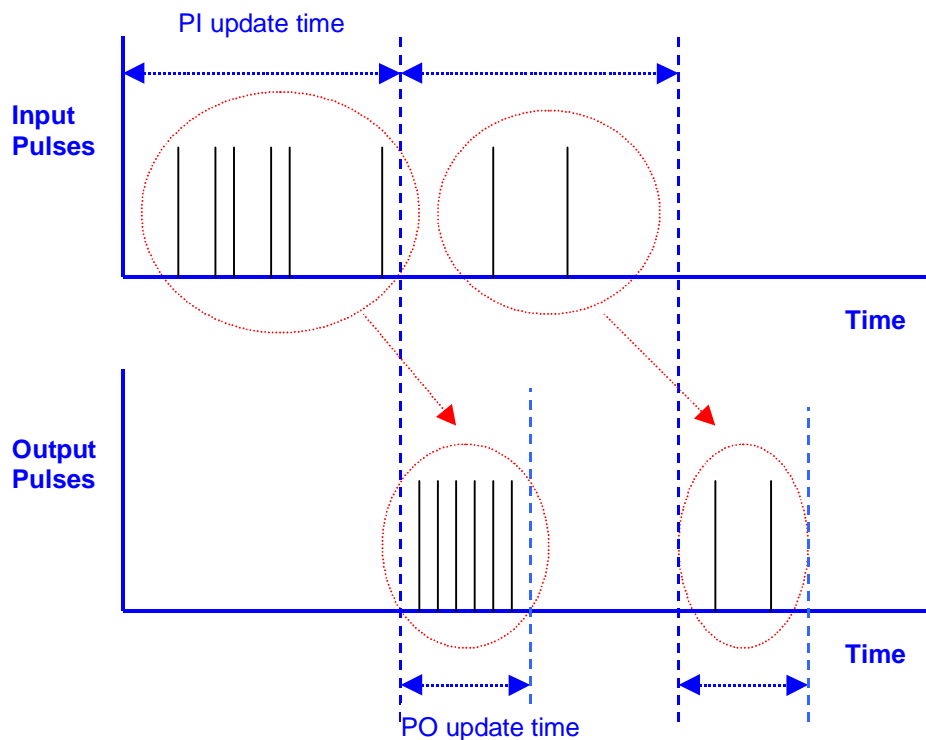

As well as accumulating the pulse input, the 105 module will also calculate the rate of pulses. **Pulse rates** are treated as an “internal” analogue input and are configured with analogue sensitivities for change-of-state transmissions. The maximum pulse rate corresponding to 20mA output may be configured by the user.

3.1.3 Analogue Set-points

On 105-1 modules, the “AI 1” input may be used to trigger the analogue set-point status.

High set point and low set point levels are configurable. This set-point status turns ON when the analogue input moves below the low level, and turns OFF when it moves above the high level. The high level must always be greater than, or equal to, the low level set point. This set-point status may be mapped (inverted, if required) to any output in the network. The set-point status is effectively an internal digital input.

On 105-2 modules, each analogue input has set-point values for controlling digital outputs. The set-point operation works as for the 105-1 module.

3.1.4 Start-up Poll

After a 105 module has completed its initial diagnostics following power up, it will transmit update messages to remote modules based on the values of the module's inputs. The module's outputs will remain in the reset/off/zero condition until it receives update or "change-of-state" messages from the remote modules.

The 105 module can transmit a special "start-up poll" message to another module. The remote module will then immediately send update messages to this module such that its outputs can be set to the correct value. Start-up polls will only occur if they are configured. It is necessary to configure a start-up poll to each remote module which controls the module's outputs. For further information, refer to Chapter 4 **Configuration**.

3.1.5 Communications Failure (CF)

The internal communications failure (CF) status is set if a module does not receive an acknowledgement message after five attempts at transmitting a message. The CF status may be configured to set a local digital output for an external alarm.

Although the CF status can set an output, it will not reset the output. That is, once communications is re-established (and the CF status is reset), the output will stay "on". The Reset Output feature (see below) is used to reset the output.

The output will reset only when no communications failures occur within the configured "Reset Output Time" for the output that CF status is mapped to. Note that if the reset output time is not enabled, the CF status will remain set forever, once an unsuccessful transmission occurs. See Chapter 4 **Configuration** for further details.

3.1.6 Resetting Outputs

Each digital and analogue output may be individually configured to reset if that output has not received a change-of-state or an update message within a certain time period. Generally this time is set to twice the update period, so at least one update can be missed before an output is reset.

In most cases it is desirable to reset outputs which are controlling equipment if there is a system failure, however alarm or indication outputs are not reset so the last valid indication remains shown. See Chapter 4 **Configuration** for further details.

3.2

System Design Tips

The following tips will help to ensure that your system operates reliably.

3.2.1 System Dynamics

It is important to be aware of the dynamics of the 105 system. Digital inputs have a minimum “debounce” delay (default 0.5 sec) - that is, a change message will not be sent for 0.5 sec after a change has occurred. Analogue inputs and outputs have time delays of 1 to 2 seconds.

Messages transmitted via serial link are received in less than 20 mSec, however a message sent by radio takes approx 60 mSec.

These delays are not significant in most applications, however if your application requires faster responses, then the above delays need to be considered.

3.2.2 Radio Channel Capacity

Messages sent on a cable link are much faster than on a radio channel, and the capacity of the radio channel must be considered when designing a system. This becomes more important as the I/O size of a system increases.

The 105 modules are designed to provide “real-time” operation. When an input signal changes, a change message is sent to change the output. The system does not require continuous messages to provide fast operation (as in a polling system). Update messages are intended to check the integrity of the system, not to provide fast operation. Update times should be selected based on this principle. The default update time is 10 minutes - we recommend that you leave these times as 10 minutes unless particular inputs are very important and deserve a smaller update time.

It is important that radio paths be reliable. For large systems, we recommend a maximum average radio channel density of 100 messages per minute, including change messages and update messages. We suggest that you do not design for an average transmission rate of greater than 40 per minute - this will give a peak rate of approx 100 per minute. Note that this peak rate assumes that all radio paths are reliable - poor radio paths will require re-try transmissions and will reduce the peak channel density. If there are other users on the radio channel, then this peak figure will also decrease.

The 105 modules will only transmit one message at a time. If re-tries are necessary, another message cannot start. The time between re-tries is a random time between 1 and 5 seconds. The time for five tries is between 5 and 21 seconds. Another message cannot be sent until the last one has finished. This delay will obviously have an affect on a busy system.

3.2.3 Radio Path Reliability

Radio paths over short distances can operate reliably with a large amount of obstruction in the path. As the path distance increases, the amount of obstruction which can be tolerated decreases. At the maximum reliable distance, “line-of-sight” is required for reliable operation. If the path is over several kilometres (or miles), then the curvature of the earth is also an obstacle and must be allowed for. For example, the earth curvature over 10 km is approx 4m, requiring each antenna to be elevated at least 5m to achieve “line-of-sight” even if the path is flat.

A radio path may act reliably in good weather, but poorly in bad weather - this is called a “marginal” radio path. If the radio path is more than 20% of the maximum reliable distance

(see Specification section for these distances), we recommend that you test the radio path before installation. Each 105U module has a radio path testing feature - refer to section 6.2 of this manual.

There are several ways of improving a marginal path :-

- Relocate the antenna to a better position. If there is an obvious obstruction causing the problem, then locating the antenna to the side or higher will improve the path. If the radio path has a large distance, then increasing the height of the antenna will improve the path.
- Use an antenna with a higher gain. Before you do this, make sure that the radiated power from the new antenna is still within the regulations of your country. If you have a long length of coaxial cable, you can use a higher gain antenna to cancel the losses in the coaxial cable.
- If it is not practical to improve a marginal path, then the last method is to use another module as a repeater. A repeater does not have to be between the two modules (although often it is). If possible, use an existing module in the system which has good radio path to both modules. The repeater module can be to the side of the two modules, or even behind one of the modules, if the repeater module is installed at a high location (for example, a tower or mast). Repeater modules can have their own I/O and act as a “normal” 105U module in the system.

3.2.4 Design for Failures

All well designed systems consider system failure. I/O systems operating on a wire link will fail eventually, and a radio system is the same. Failures could be short-term (interference on the radio channel or power supply failure) or long-term (equipment failure).

The 105 modules provide the following features for system failure :-

- Outputs can reset if they do not receive a message within a configured time. If an output should receive an update or change message every 10 minutes, and it has not received a message within this time, then some form of failure is likely. If the output is controlling some machinery, then it is good design to switch off this equipment until communications has been re-established.

The 105 modules provide a “drop outputs on comms fail” time. This is a configurable time value for each output. If a message has not been received for this output within this time, then the output will reset (off, in-active, “0”). We suggest that this reset time be a little more than twice the update time of the input. It is possible to miss one update message because of short-term radio interference, however if two successive update messages are missed, then long term failure is likely and the output should be reset. For example, if the input update time is 3 minutes, set the output reset time to 7 minutes.

- A 105 module can provide an output which activates on communication failure to another module. This can be used to provide an external alarm that there is a system fault.

3.2.5 Indicating a Communications Problem

There are two ways to provide an indication of communications problems. The first is to map the internal CF status to a local output. The output will then activate when a comms fail

occurs. This method provides an indication immediately an attempt to transmit a message fails. If you want the radio path to be “tested” regularly, then you need to configure the update times such that transmissions occur regularly (however do not overload the radio channel).

Notes regarding this method:

1. Each CF mapping corresponds to only one remote address - you need to make separate mappings for each remote address. You can map the CF for each remote module to a separate output, or to the same output.
2. You need to reset the comms fail output using the “reset output” parameter. Select a reset time which is greater than the effective update time period. For example, if there are four inputs mapped from module #1 to module #2, each with a 10 minute update, then you would expect at least four transmissions in each 10 minute period. At module #1, a comms fail for #2 is mapped to DO1. If you set the “reset time” for DO1 to 10 minutes, then there will be at least four transmissions made during the reset period - that is, the output will only reset when the communications has been successful four times.
3. This method will not work for radio links with repeaters. If a repeater is used, you will need to use the second method described below.

The second method is to set up a “comms OK” output using the “Reset Outputs” function. Consider a link between module #1 and #2, and assume that you want a “comms OK” output at #1. At #2, map an unused input to an output at #1 such that the output is normally active (‘on’). If there is no spare inputs at #2, you can use an internal input such as “low voltage status”. You will need to invert the mappings such that the output is normally on (because the input is normally off).

At #1, configure a reset time for the output. The reset time should be greater than the update time for the mapping at #2. If #1 fails to receive update messages from #2, then the output will reset, indicating a communications failure. Notes regarding this method:

1. This method will work with repeaters in the link.
2. The “comms OK” output is fail-safe - if module #1 fails, then the output will reset indicating a problem.
3. You should use separate outputs to indicate “comms OK” of different remote modules.
4. It is recommended that you set the reset time at #1 to more than twice the update time of the mapping at #2. This means that the comms OK output will only reset if #1 misses two consecutive updates from #2.

3.2.6 Testing and Commissioning

We recommend that you set-up and test the system with all of the modules together **before** you install the modules. It is much easier to find a configuration problem.

When the system is configured, record the radio signal strength and background noise level for each radio link. If there are future communications problems, you can compare the present measurements to the as-commissioned values.

Chapter Four

CONFIGURATION

4.1

Introduction

The 105 modules are configured by connecting a computer (PC) using the 105 Configuration Software programme. The same software program is used to configure 105U-C modules - for more information, refer to the separate 105U-C User Manual.

Each 105 module is configured with a system address and a unit address. The system address is common to every module in the same system, and is used to prevent "cross-talk" between modules in different systems. Separate networks with different system addresses may operate independently in the same area without affecting each other. The system address may be any number between 1 and 32 767. The actual value of the system address is not important, provided all modules in the same system have the same system address value. **A system address of zero should not be used.** The use of a random number is recommended.

Each unit must have a unique unit address within the one system. A valid unit address is 1 to 127. A network may have up to 95 individual modules communicating via radio (unit addresses 1 to 95), each with up to 31 modules communicating via RS485 (unit addresses 96 to 127). In the network, any individual input signal may be "mapped" to one or more outputs anywhere in the system. The unit address determines the method of communication to a module. Any module with a unit address between 96 and 127 will communicate by RS485 only. Other units with a unit address below 95 may communicate by radio *or* RS485 - the unit will determine which way to communicate depending upon the unit address of the destination module. For example, Unit 31 will talk to Unit 97 by RS485 only, but will talk to unit 59 by radio only. 105S units must always have a unit address between 96 and 127 as serial communication is the only method of communication available. **A unit address of zero should not be used.**

The four different products in the range can be used together in the same system, as well as 1105U-C modules. Inputs to one product type can be transmitted to outputs of another product type. For example, an analogue input to a 105-2 may be transmitted to an analogue output of a 105-1 or 105-3. Repeaters may be any product type.

The 105-1 and 105-2 modules require only one unit address. The 105-3 and 105-4 modules use two addresses, however only one unit address has to be entered. The 105-3 and 105-4 modules require two addresses because of the large number of output channels. If the "entered" unit address is an even number, then the second address is the next number. If the "entered" address is an odd number, then the second address is the previous number. So the two addresses are two subsequent numbers, starting with an even number. If a 105-3 module is given a unit address of 10, then it will also take up the unit address 11 and will accept messages addressed to either 10 or 11. It is important to remember this when allocating unit addresses to other modules in the system.

Warning - do not allocate the address number 1 to a 105-3 or 105-4.

In addition to these network configurations, operational parameters called **User Options** may be configured to change the features of the 105 operation.

4.2 Easy Configuration Using Default Settings

If your application requires only a single pair of 105 modules, communicating via radio or serial link, default settings may satisfy your needs. If so, no configuration is required. Essentially, all inputs at Module A are reflected at the corresponding outputs at Module B. All inputs at Module B are reflected at the corresponding outputs at Module A.

For **105-1 modules**, the default configuration is as follows :-

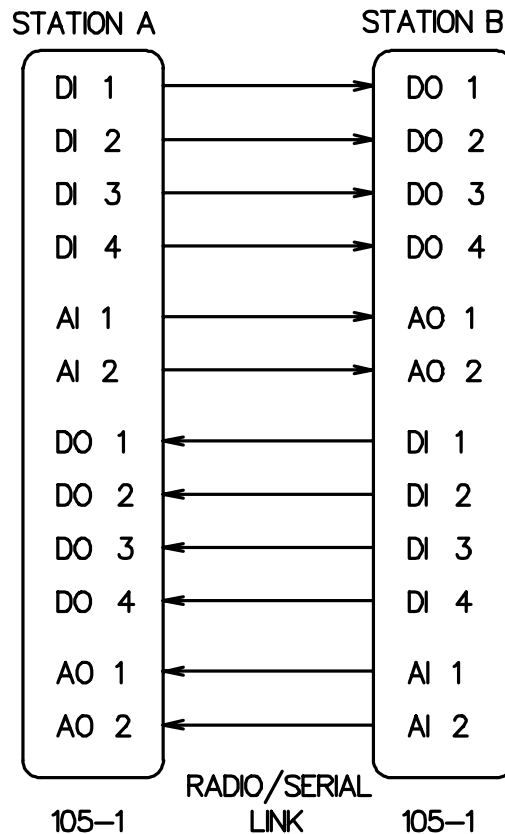

In this configuration, the “PO” Pulse output is inactive and no special action is taken on “Comms fail”, “Mains fail” or “Battery Low”. “DI 1” is configured as a digital and not a pulse input.

For 105-2 and 105-3 modules, the default configuration is as follows :-

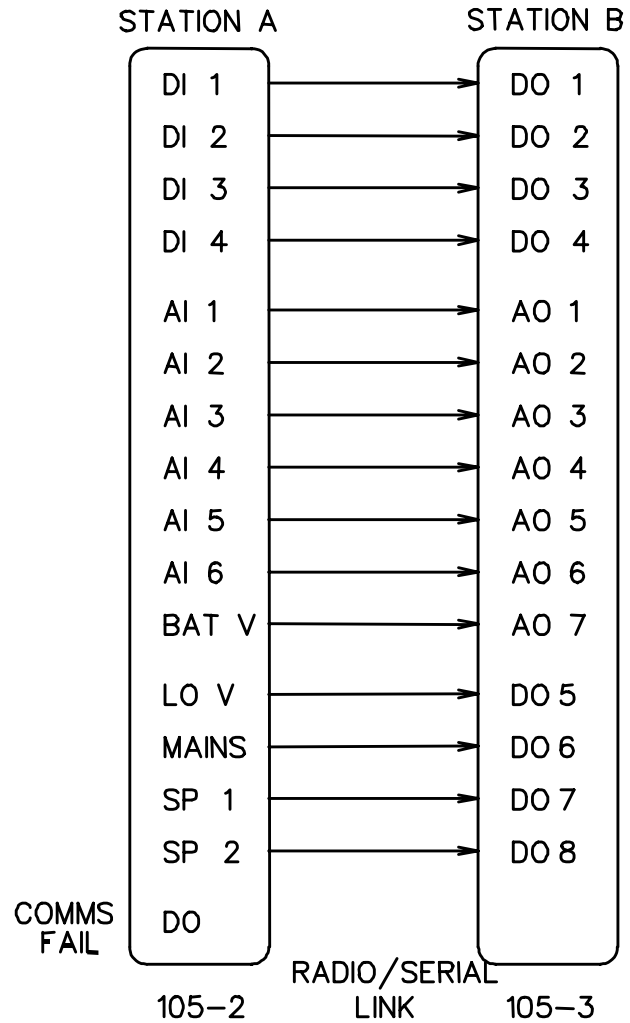

The following table details the default values for **User Options**:

Option	Factory Set Value
Update transmissions	Every 10 minutes
Analogue Change-of-state sensitivity	3%
Reset outputs on Comms fail	No
Analogue Setpoints (if mapped)	Low Set point = 30% High Set point = 75%
Pulse Output Rate Scaling (if Pulse Rate is mapped)	100 Hz
Digital Input Debounce Time	0.5 seconds

If any of the above values are not appropriate to your system, Section 4.4 below will detail how to change one or all of the above variables.

4.3 105 Configuration Software

This chapter describes installation and operation of configuration software for the 105 radio and serial telemetry modules. The configuration software runs on a conventional PC as a Windows application. The software creates a configuration file which can be loaded into a 105 module via RS232. The configuration software also allows the configuration of a 105 module to be loaded for display and modification. Configuration files are created and stored in project directories.

Configuration of 105 modules consists of entering I/O mappings, and selecting User Options. An I/O mapping is a link between an input on the module being configured and an output on another module. A mapping has the form :-

DI3 → Out2 at 4 via 3, 11

This mapping links DI3 on this module to output channel 2 on the module with address 4, and modules 3 and 11 are repeaters.

User Options may be selected to change the configuration of specific features.

Mappings configured to a 105U-C have the form :-

AI2 → I/O Reg 1036 at 10 via 7

This mapping links AI2 on a 105 module to I/O Register 1036 in a 105U-C with address 10. Module #7 is used as a repeater. The host device connected to the 105U-C can read the I/O register.

4.3.1 Hardware and Software Requirements

The configuration software is available on a CD, and needs to be installed on your PC before you can use it. The CD contains a setup file called *setup.exe*. Select the configuration software window on the Product CD and an installation Wizard will guide you through the installation procedure. To upload and download configuration files to a module, you will need a RS-232 serial cable as shown below.

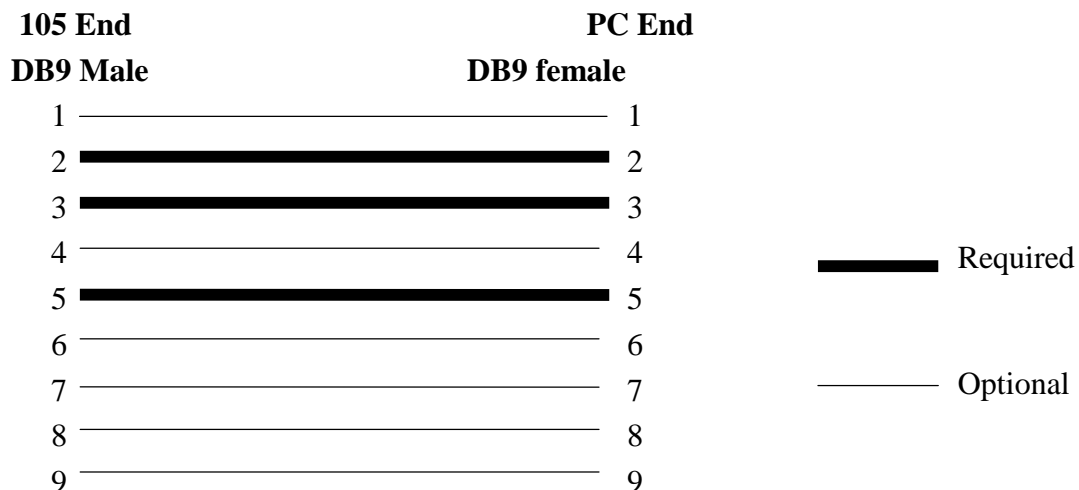

4.3.2 Programme Operation

Start the software by either clicking on the start bar and navigating to the Configuration menu or by running ESERIES.EXE

The Initial screen will appear. The configuration is performed for a complete system. The necessary configuration stages are :

- select system name and system address
- select individual units and unit addresses
- configure I/O mappings for each unit
- configure user options for each unit
- compile the system, which generates configuration files for each unit
- load the configuration files into each unit.

From the initial screen, you can select an existing project, or start a new project. The name of the project will create a new directory which will eventually contain the configuration files for the modules in this system.

When you have selected the project, a screen will appear where you may enter the system address.

If you are editing an existing project, the system address will already have been entered. Do not change the system

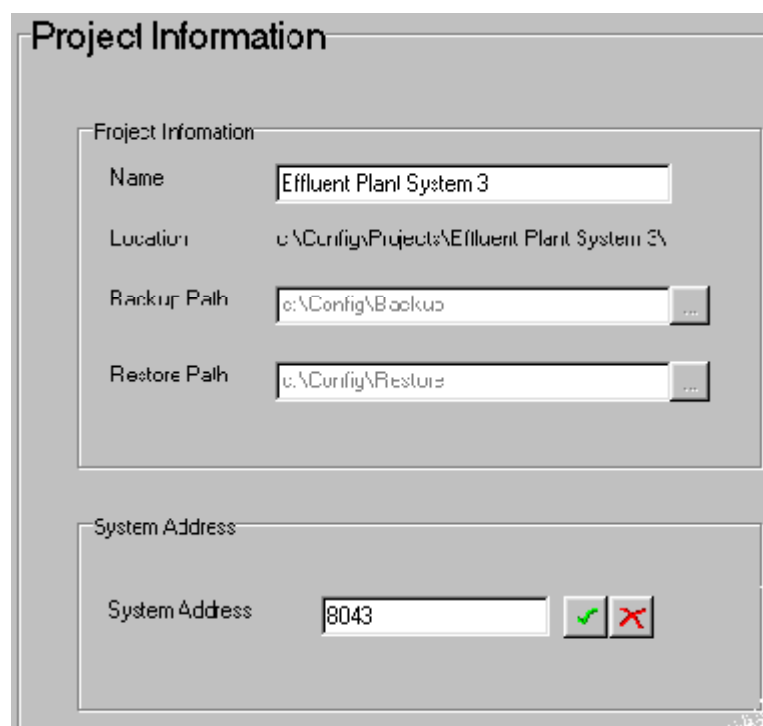
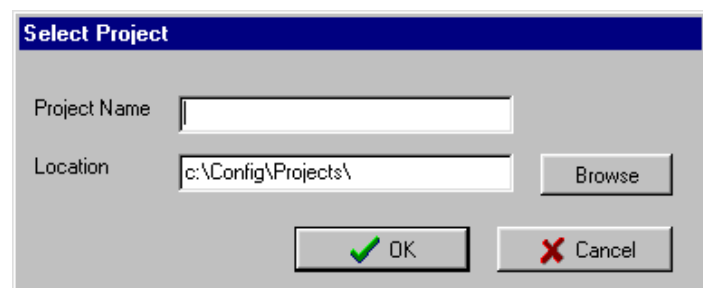
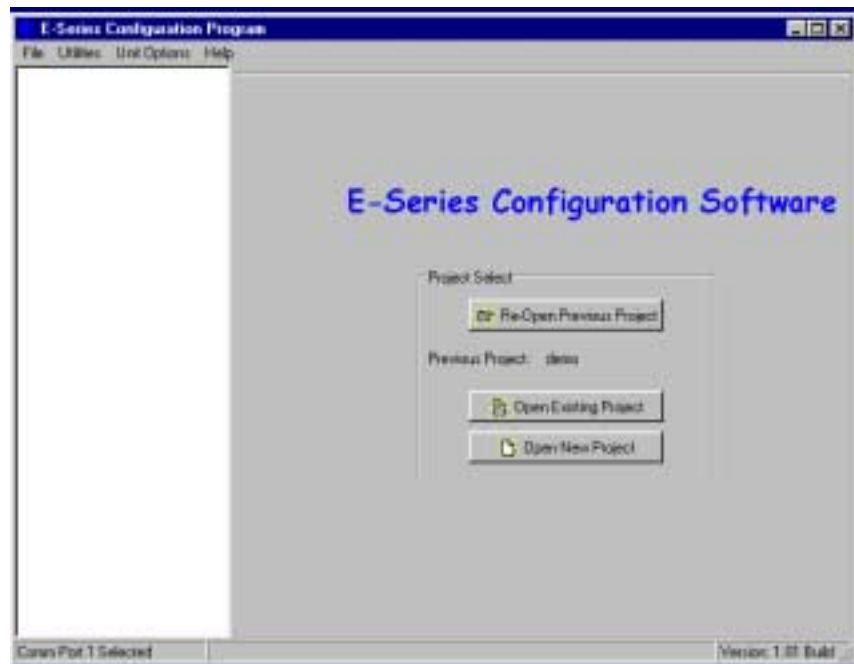

address unless you are going to re-programme all of the modules in the system.

Double-click on the project name on the menu on the left side of the screen. “Units” will appear. You can now enter the types of units which will be used in the system. If you double-click on “Units”, then the modules that have already been selected will appear.

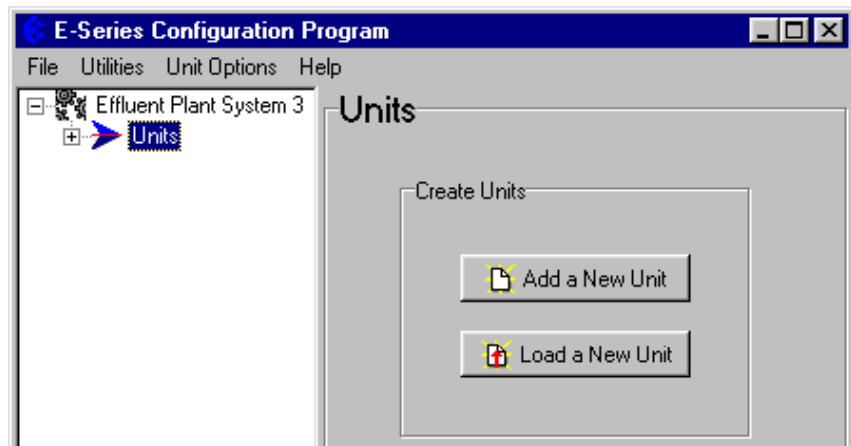

Loading configuration from an existing module

To load the configuration from a module, connect the module to the PC via the RS232 cable and click on “Load Unit”. This will allow you to view the module configuration, change it, or copy it for another module - refer to section 4.3.3 for more information.

Adding a new module to the system configuration

To add a new module to the system configuration, click on “Units” on the left-hand menu and then “Add Unit”. Select the type of module from the list. The programme will ask you to select the unit address. For 105U modules, select an address between 1 and 95. For 105S modules, select an address between 96 and 127.

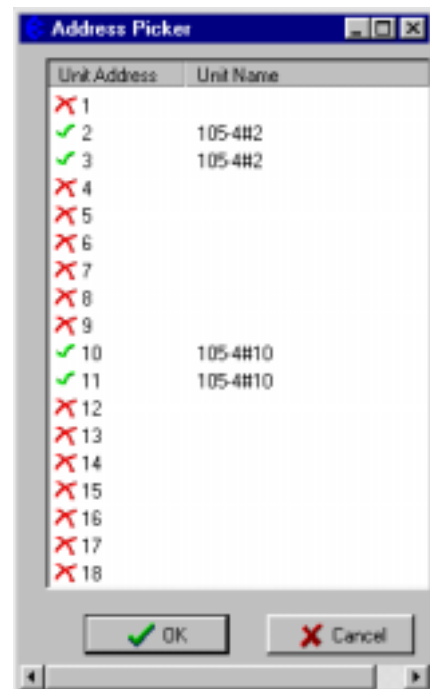

The default name for a unit will include the unit address.

For example, “105-4#8” is a 105-4 module with unit address 8 (and also 9, as a 105-4 takes two unit addresses). You can change the name of a unit - for example, you could replace the default name with “Pump Station 14”.

Deleting a Unit

A module can be deleted from the configuration by highlighting the unit and selecting “Delete Unit”.



Configuring an individual module

Double-click on a unit shown on the left-hand menu. The configuration options for each unit will appear. We recommend that you configure I/O mappings first, and then other options.

Select “Mappings” and the following screen appears. There are three types of mappings:

- I/O mappings which link inputs to outputs
- Poll mappings, which enables a module on start-up to request set its outputs quickly
- Comms Fail mappings, which maps communication failure status to an output on the local module.

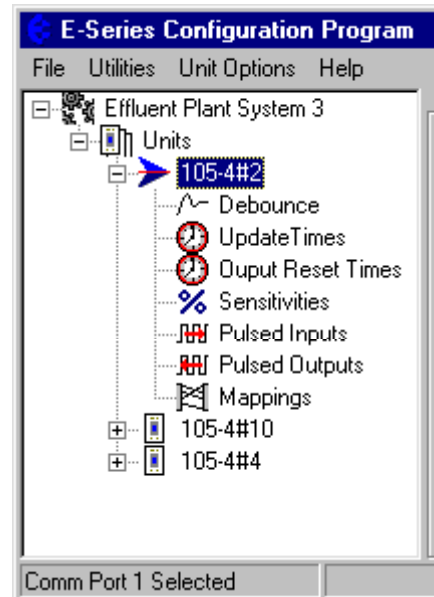

I/O Mapping To enter an I/O mapping, select “New I/O Mapping”.

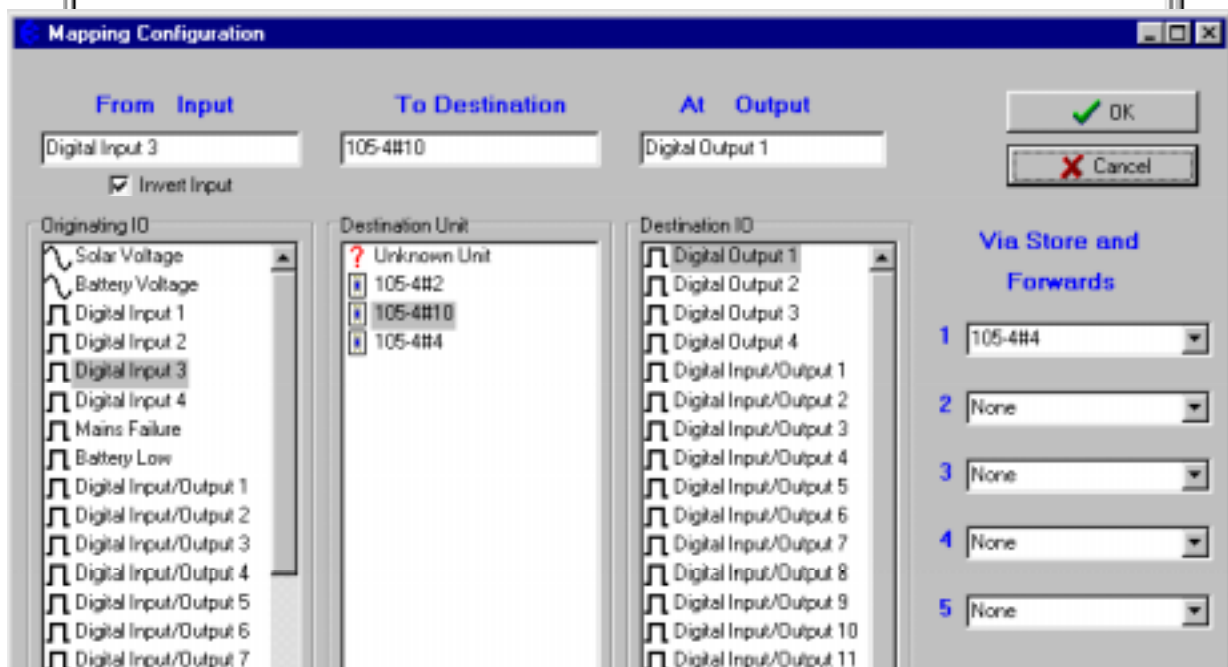
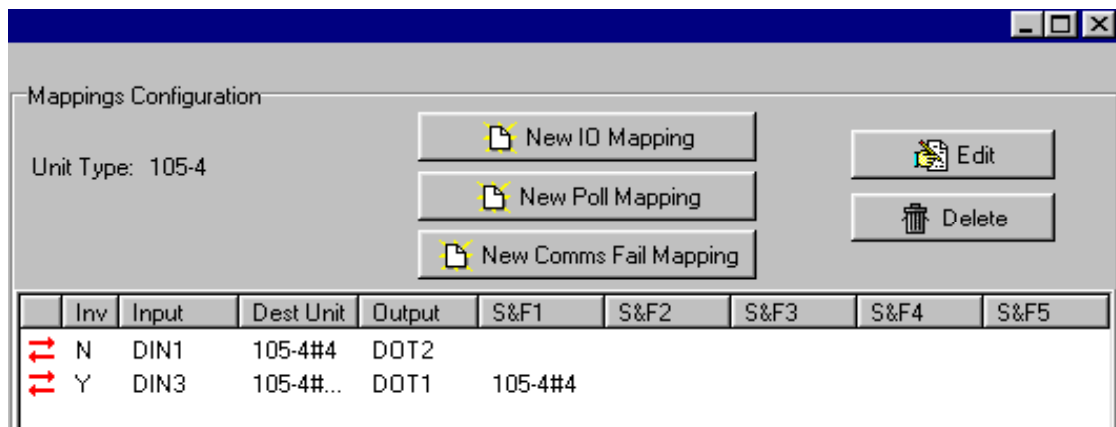

1. The I/O mapping display will show all inputs at the selected module - both physical inputs and internal inputs. Select the input to be mapped.

Every radio module (105U) should have at least one mapping configured. If no inputs are being used at this module, map an unused input or an internal input (for example, Low Volts). Map the input to an output which is not being used. If the destination module is a 105U-2, then enter “2” in the “At Output” box - this will allow the only output at the 105U-2 module to be used for something else.

2. If you wish to invert the mapping, select the “Invert Input” box. If you invert an input, then the output will be the reverse of the input. Analogue I/O can also be reversed - 0mA will be 24mA, 4mA will be 20mA etc. **Do not invert pulse inputs.**
3. The invert function is not available on 105-2 modules - only inverted digital inputs are available (as internal inputs on the input list).
4. To select the destination module, you can either select the module from the “Destination Unit” list, or enter the unit address in the “To Destination” box. You can enter an address that has not yet been allocated to another unit.
5. You can select the output by entering the output number (1 – 255) in the “output” box, or select an output from the displayed list. There will only be a list of possible outputs displayed if at step 2 you selected a destination unit that has already been configured in the system.

The output numbering for each module is:

	105-1	105-2	105-3 First addr (Even)	105-3 Second addr (Odd)	105-4 First addr (Even)	105-4 Second addr (Odd)
Output 1	DO 1	DO 1	D/P O 1	AO 1	D/P O 1	DIO 5
Output 2	DO 2	None	D/P O 2	AO 2	D/P O 2	DIO 6
Output 3	DO 3	None	D/P O 3	AO 3	D/P O 3	DIO 7
Output 4	DO 4	None	D/P O 4	AO 4	D/P O 4	DIO 8
Output 5	AO 1	None	DO 5	AO 5	DIO 1	DIO 9
Output 6	AO 2	None	DO 6	AO 6	DIO 2	DIO 10
Output 7	PO	None	DO 7	AO 7	DIO 3	DIO 11
Output 8	None	None	DO 8	AO 8	DIO 4	DIO 12

6. If you select a 105U-C as the destination module, you will be asked to select a I/O Register as the destination “output”. Note that the grey-shaded I/O registers have already been allocated.
7. Select any intermediate repeater units needed to reach the destination address (entered in order of nearest to furthest repeater). You can either select from the list of configured units or enter the unit address in the “Repeater” box. If no repeaters are required, do not enter anything in the repeater boxes. If only one repeater address is required, enter the

address in box 1 and leave the other repeater boxes empty.

It is possible to configure multiple mappings for an input - each mapping will generate separate transmissions. We recommend that you do not configure multiple mappings to the same output as the output will have the value of the last message that it receives. Each output should have only one mapped input.

It is possible to map a digital input to an analogue output - the output will be maximum value when the input is on and minimum value when the input is off. It is also possible to map a analogue input to a digital output - the output will be on when the input is equal or greater than 12mA and off when the input is less than 12mA.

For more information on using 105S modules, refer to Section 4.3.5.

Edit existing mappings

To edit an existing mapping, double-click on the mapping line, or select the mapping line and click “Edit”.

To delete an existing mapping

To delete a mapping, select the mapping and click “delete” or alternatively right-mouse button click and select delete.

Configuring Start-Up Polls

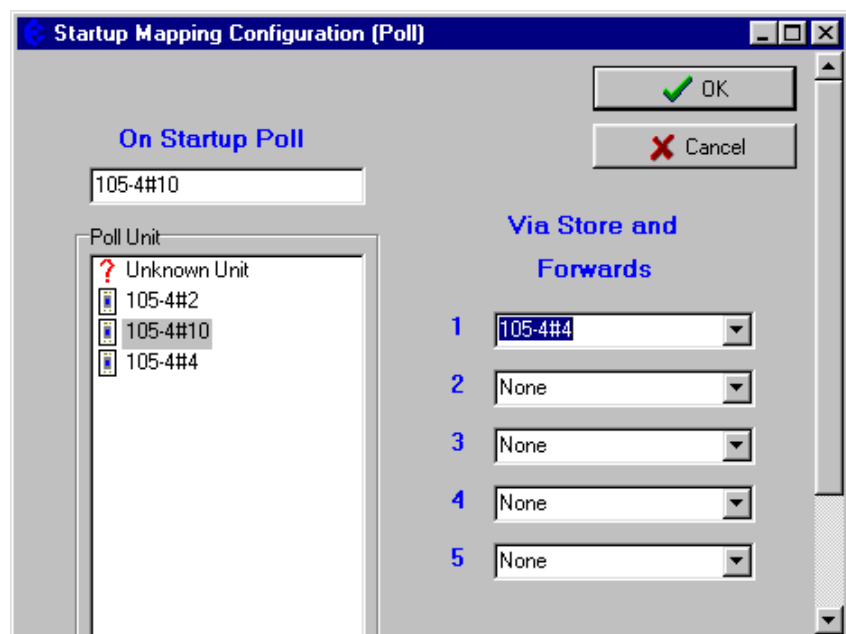

When a unit is first turned on, its outputs will not be set until it receives update messages from other units in the system. To ensure that outputs are set as soon as possible after start-up the unit may be configured to “Poll” any other units with mappings to its outputs.

Select the remote unit to be polled from the unit list, or enter the unit address in the box. If the remote unit communicates via repeaters, select the repeater units or enter the repeater addresses.

Remember that if more than one remote unit is controlling the local outputs, then more than one start-up poll should be configured.

Configuring Comms Fail Mappings

Each module has a “comms fail” status which may be mapped to a local output. The comms fail status is active (on) if the module is transmitting a message and does not receive an acknowledgement after five tries. By setting the comms fail status to a local output, you can provide a communications alarm. The local output can be digital or analogue - if analogue, the output will go to maximum value.

Although communication failure will activate the output, successful comms does not reset the output. You must use the “Reset outputs on comms fail” option (Refer to User Options section).

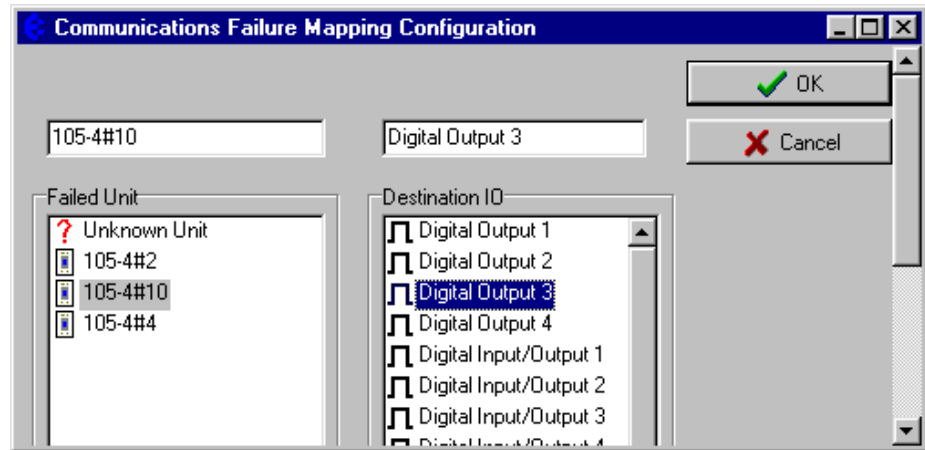

Each remote module has a separate comms fail status - you enter a separate comms fail mapping for different remote addresses. You can configure several comms fail mappings to the same output - the output will be active if there is comms fail to any of the remote addresses. You can also map a configure an output to activate upon any comms fail. Configuring a “Comms Fail Address” of zero causes communication failure to any destination module to be indicated on the selected output.

For example, if “Comms fail to unit 12” is configured to DO1, then the 105 module will set (or activate) DO1 each time communications to unit 12 is not successful. If DO1 has a “Reset output” time of 10 minutes configured for DO1, then DO1 will reset (de-activate) 10 minutes after the last comms fail to unit 12.

Debounce Configuration

Debounce is the time which an input must stay stable before the 105 module decides that a change of state has occurred. If a digital input changes (say 0 → 1) and changes again (1 → 0) in less than the debounce time, then the 105 module will ignore both changes. Debounce may be configured for digital inputs on the 105-1, 105-2 and 105-4 modules and the analogue inputs on the 105-2

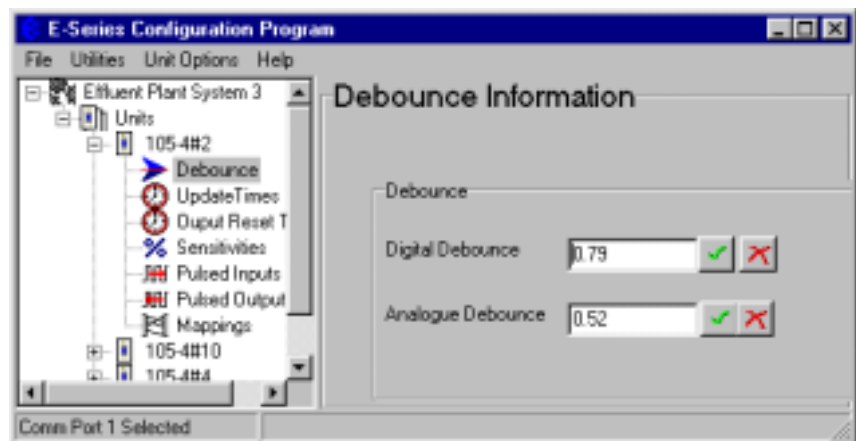

digital inputs on the 105-1, 105-2 and 105-4 modules and the analogue inputs on the 105-2 module. The default value of 0.5 seconds is suitable for most applications. In applications where a digital input may turn on and off several times slowly (for example, security switches or float switches) a debounce time of up to 8 seconds may be configured. *The configured debounce time has no affect on pulse inputs.*

Note that the analogue debounce is not configurable for the 105-1, but is configurable in the 105-2.

Update Time Configuration

Update messages are sent if a change message has not occurred within the update time period. The update time may be set for each input - both physical and internal inputs.

The default period is 10 minutes for all inputs, except for pulse inputs (1 minute). Short update times should only be used in special circumstances. It is important to remember the principle - "Less radio traffic means better communications". Frequent updates from multiple units causes congestion of the radio channel, which results in increased communication

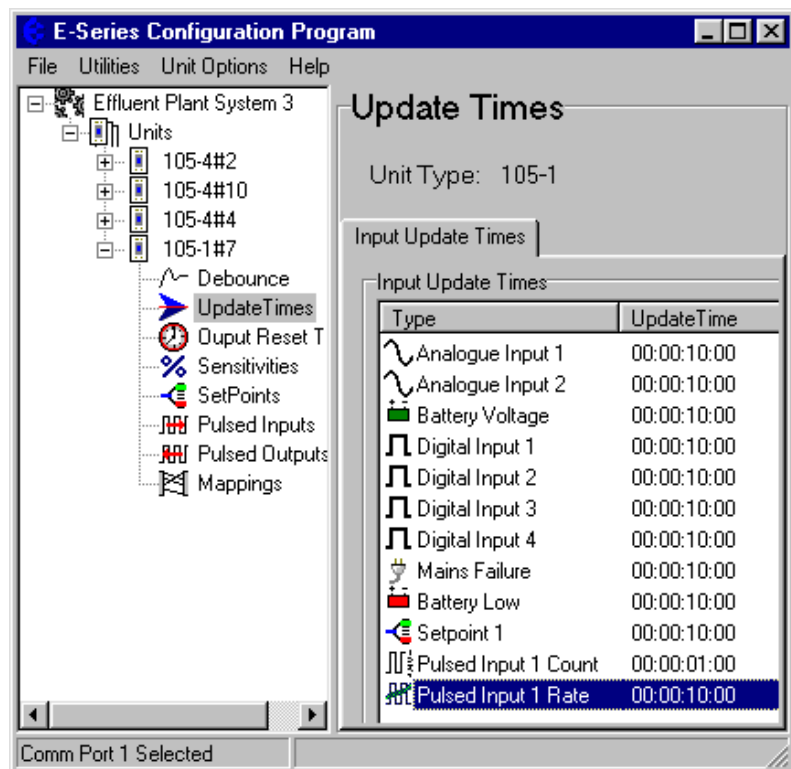

failures and poorer performance of the system. To change an update time, select "Update Times" on the left-hand menu and double-click the selected input. The update time will be shown in days:hours:minutes:seconds. Change the values in each field. The display also shows the maximum and minimum values.

For the 105-1, -2 and -3 modules, the maximum update time is 16 minutes, however the update time for 105-4 inputs can be up to 5 days.

If a zero value is entered as an update time, then the input will not update at all.

Changing Multiple Settings

You can change the Update Times of several inputs simultaneously by using the <Shift> Select feature. For example, if you want to change all digital inputs to 1 minute update, you could change each individually, or you could "block" the four digital inputs using the "Shift" Select feature and select "Edit". You only need to enter the change once to change all of the inputs selected. This feature is also available with the other configurable parameters.

Output Reset Time Configuration

This allows the **Comms Fail Time** to be selected - this is the time for an output to reset if it has not received an update or change message.

Each output on the unit, either analogue or digital, may be configured to reset (off or 0mA) when no update transmission has been received for a certain time. This option can be used to ensure that communications failure will not result in loss of control. For example, outputs connected to pumps should be configured to reset on communications failure so that the pump will turn off. The default condition is zero (no reset).

If the reset time is less than the update time, then the output will reset when the reset time expires, and then set again when the update message is received. We recommend that the reset time be a little more than twice the update time.

To set an output reset time, select “Output Reset Times” on the left-hand menu and double-click the selected input.

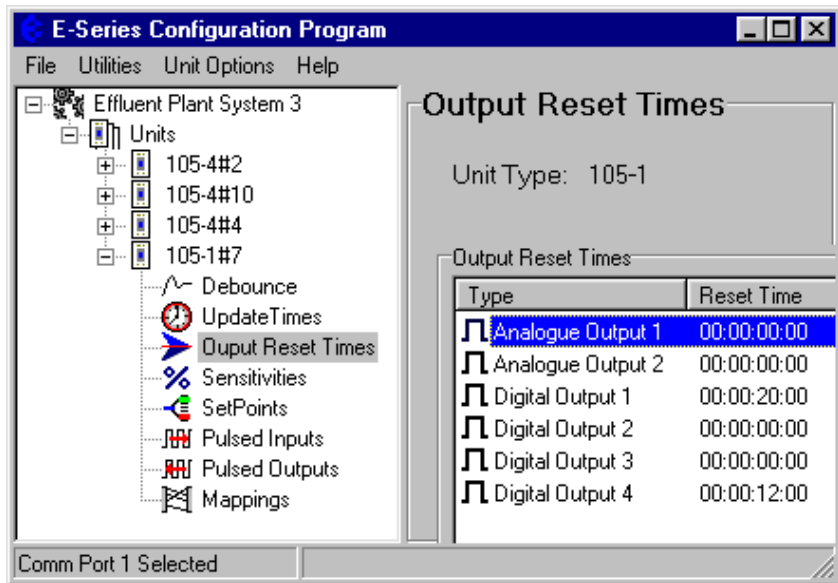

The update time will be shown in days:hours:minutes:seconds. Change the values in each field. The display also shows the maximum and minimum values.

Analogue Sensitivity Configuration

The analogue sensitivity is the change required in an analogue input before a “Change Of State” is detected, and the new analogue value is transmitted. For input signals which vary widely over a short period of time or have a normal oscillation, the analogue sensitivity should be set to an appropriately large value. This ensures that many change messages are not transmitted in too short a time. This will result in channel congestion, as described in the preceding section.

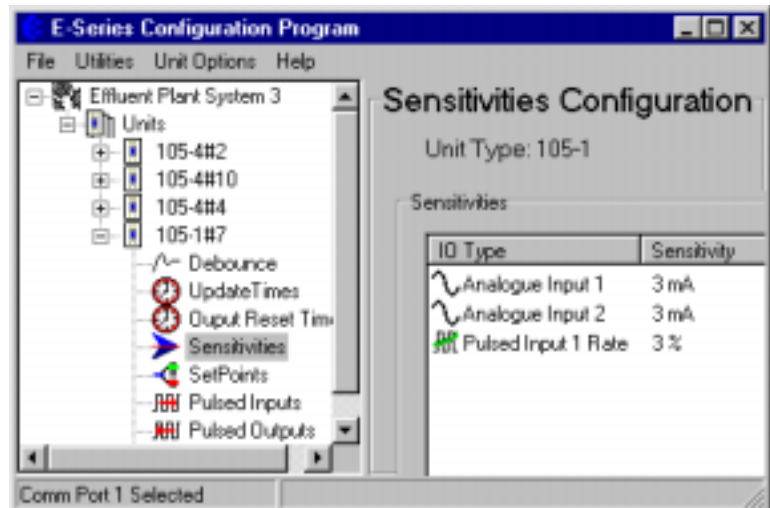

To change an analogue sensitivity, select “Sensitivities” on the left-hand menu and double-click the selected input. The sensitivity for physical inputs is shown in mA and internal input is shown as %.

SetPoint Configuration

Setpoints allow a remote digital output to be turned on and off depending on the value of an analogue input. The “set-point status” internal input must be mapped to an output for this option to have effect. When the AI is less than the Low Set-point (LSP), the set-point status will be active (on, “1”) - when the AI is more than the High Set Point (HSP), the set-point status will be reset (off, “0”). Note that the High Set Point (HSP) must always be higher than the Low Set Point (LSP). For the 105-1 module, only AI1 has set-point values. For 105-2 modules, all six analogue inputs have set-points.

Debounce time operates on the set-point status in the same way as digital inputs.

To change a setpoint values, select “SetPoints” on the left-hand menu and double-click the selected Setpoint Status.

Pulse Input Count Configuration

PI1 of the 105-2 and 105-4 modules normally count up

to 100Hz (as for the other PI’s), however can be configured to count up to 1000Hz. This configuration actually divides the input count by 10 - each count in the PI1 register is then equivalent to 10 input pulses. If PI1 is mapped to a PO, then the maximum output pulse rate is 100Hz, however each output pulse is equivalent to 10 input pulses.

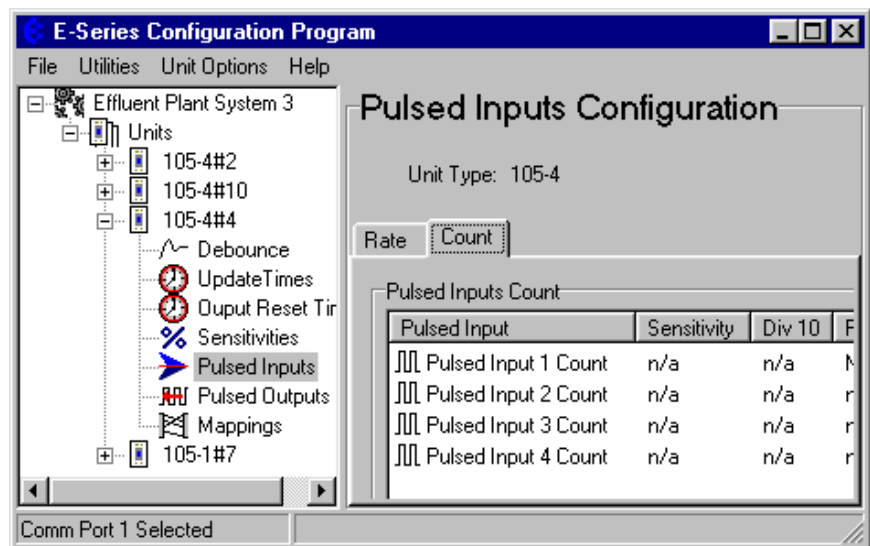
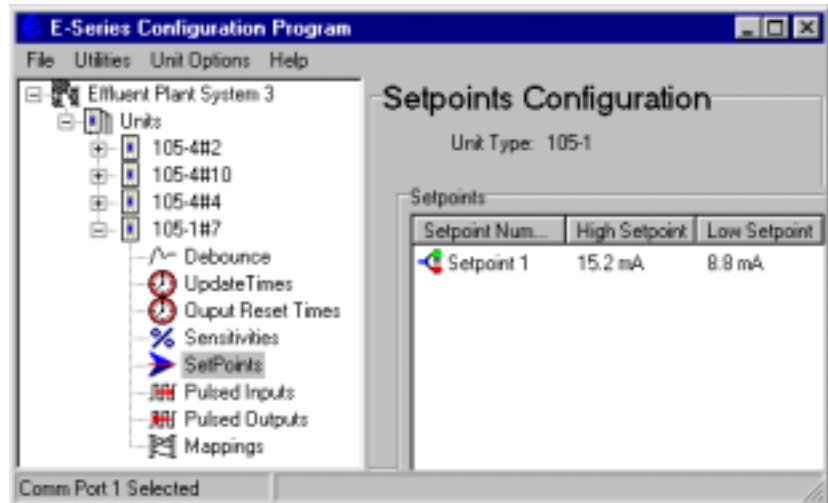

To configure the “divide by 10” feature, select “Pulse Inputs” on the left-hand menu and select the “Count” page - double-click “Pulse Input 1 Count” and enable “divide by 10” counting.

Pulse Input Rate Scale Configuration

When a pulse rate is mapped to an analogue output, the rate must be scaled to the 4-20mA output. The pulse rate scale is the rate (in Hz) corresponding to the maximum value (20 mA if mapped to an analogue output).

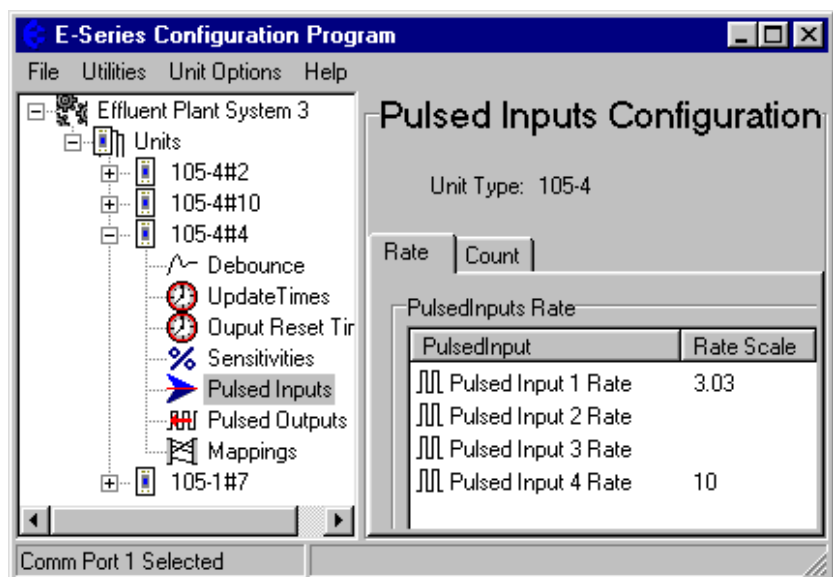

To configure the pulse rate scale, select “Pulse Inputs” on the left-hand menu and select the “Rate” page - double-click the pulse input rate and enter the scale value.

Pulse Output Update Time Configuration

The pulse output update time is the time period over which pulses are output after a PI update is received. It should be configured to correspond to the pulse input update time for the corresponding pulse input. This ensures that the pulse output rate matches as closely as possible the pulse input rate which it is reflecting.

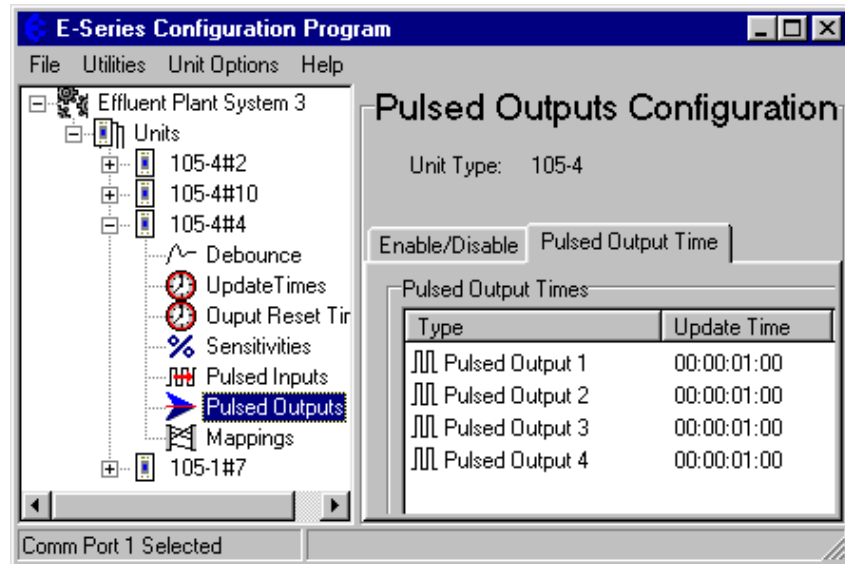

For example, if the PI update time is 1 minute, then the PO update time should also be 1 minute. If the PI update time is changed, then the PO update time at the remote module should be also changed. The PO will still operate if the time is not changed, however pulses may be output faster or slower than the input pulses.

To configure the pulse output time, select “Pulse Outputs” on the left-hand menu and select the “Pulsed Output Time” page - double-click the pulse output and enter the new time.

Pulse Output Enable

The PO's for the 105-2 and 105-4 modules are also DO1-4. To use as pulse outputs, you need to enable them as pulse outputs.

To enable pulse outputs, select “Pulse Outputs” on the left-hand menu and select the “Enable/Disable” page - double-click the pulse output to enable.

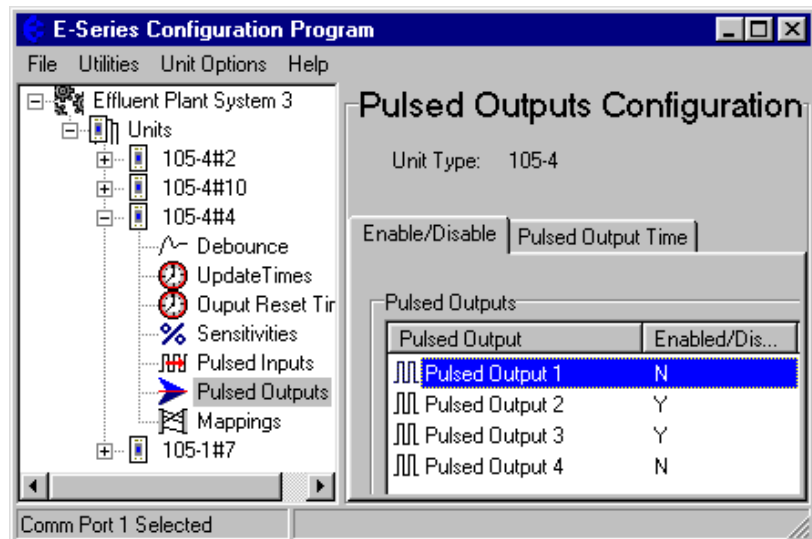

Compiling a System

When you have finished configuring the modules, you should compile the system. The compile function scans the configuration and reports any detected errors. To compile the system, select “Compile System” from the “Utilities” menu. Select the “Compile” button. The system will compile - the display will show if there are any compile errors or warnings.

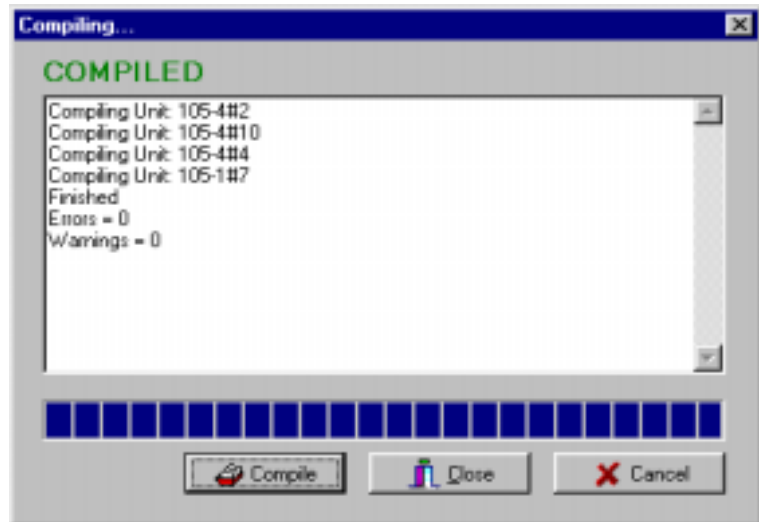

Programming Configurations to Modules

To programme a module :

- Connect the cable from the PC’s serial port to the 105 serial port (see 2.4.10 for cable connections)
- From the Utilities menu, select “Serial Port Setup”
- Select the appropriate serial port (COM1 - COM4)
- Select the unit to be configured from the left-hand menu
- Click on the “Program Unit” button.

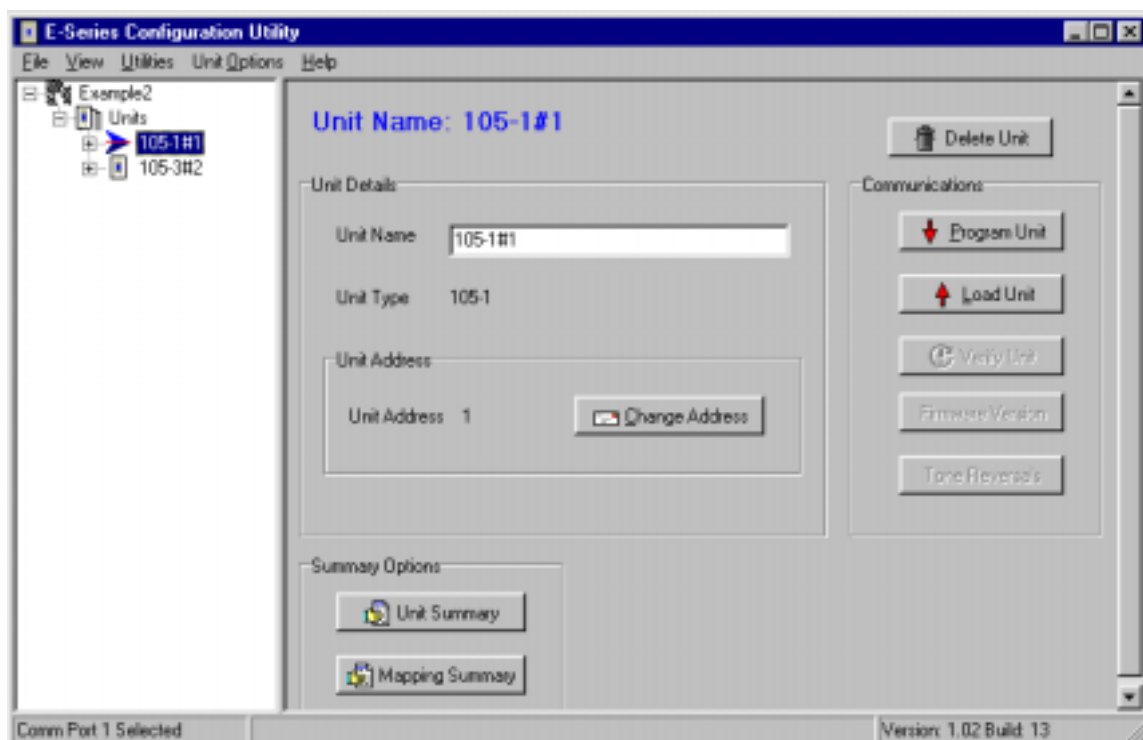

- You will be asked to confirm if the module already has a different system or unit address.

Each module will need to be programmed individually.

4.3.3 Loading Configuration from a Module

Care should be taken when loading a configuration from a module. It is easy to lose the system address and unit address. We suggest that you first view the system address and unit address - you can do this via the “Unit Options” menu. Note these addresses before loading the configuration.

When you upload the configuration, the program will check if you want to load the addresses from the module. If you do not, then the system address and unit address will change.

4.3.4 Print Options

You can obtain a print-out of each module configuration. On each unit display, there are “Unit Summary” and “Mapping Summary” windows. Each of these will display a printable information page about that module. The Unit Summary page will display the user options configured, and the Mapping Summary will display the mappings entered for that unit.

The printer may be selected from the Printer Setup option in the File menu.

4.3.5 Using 105S Modules

105S modules can be used by themselves, as “line telemetry” or “wired I/O”, or they can be used as I/O expansion for 105U modules. As the 105S modules are connected by RS485, the 105S modules can be separated from the 105U modules by some distance. There can be up to 32 addresses on the one RS485 multi-drop link. Note that each -3 and -4 module takes up 2 addresses. For example, you could have up to 32 modules sharing a multi-drop link if they are all -1 or -2 modules - if they are all -3 or -4, then you could only have 16 modules on the link.

105S modules are configured with unit addresses in the range 96 – 127.

Example 1 - Mapping to another 105S module on the same link.

The I/O mapping is done in the same way as for 105U modules.

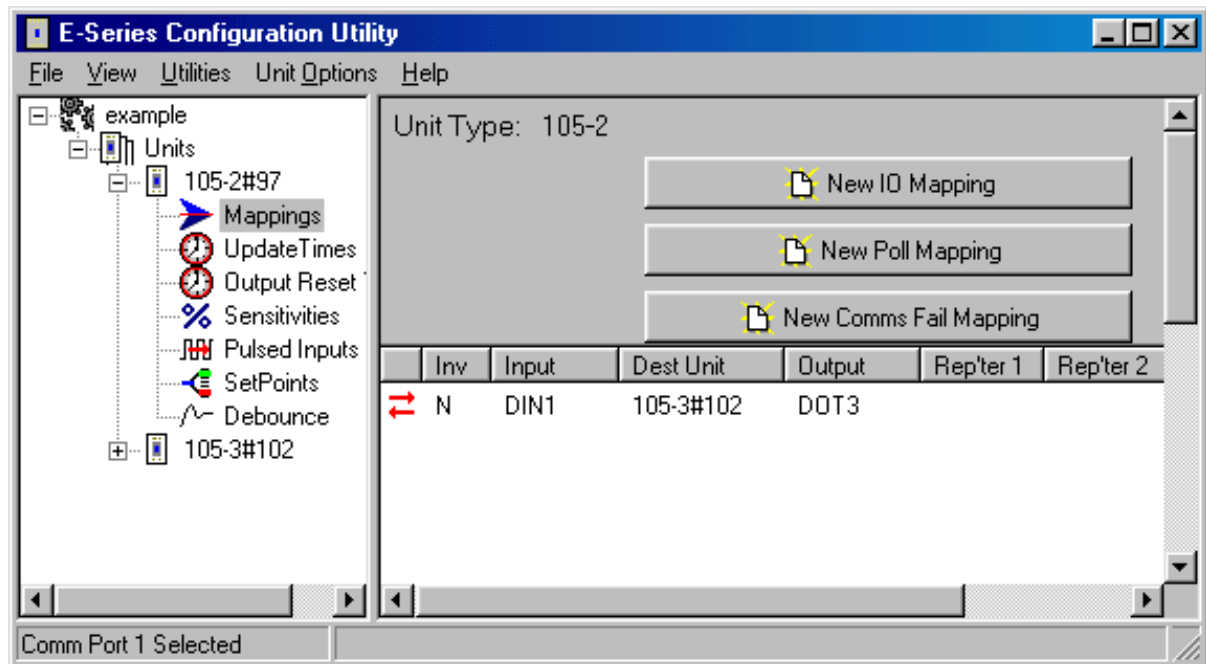
**Example 2 - Mapping to a remote 105U.**

In this example, a 105S-2 is connected to 105U-1#8. DI1 is mapped to a remote 105U-C module. The 105U that is connected to the 105S module acts as a repeater - a serial-to-radio repeater.

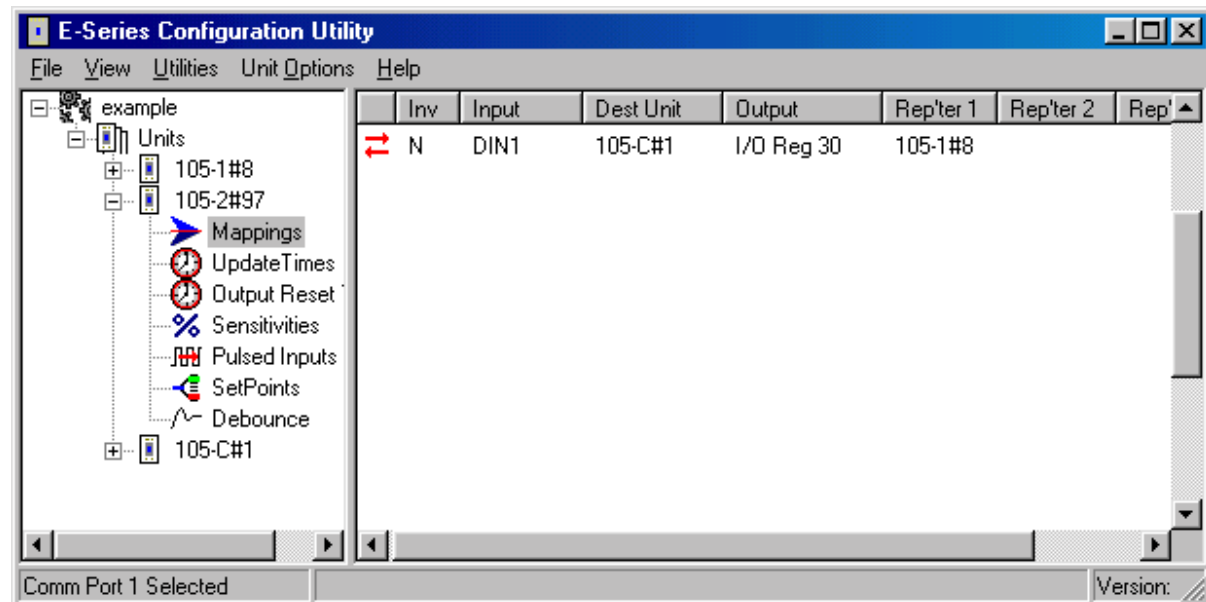

When DI1 changes, the 105S will send a message via the serial link to 105U-1#8, and this 105U module will repeat the message by radio to the 105U-C module.

Example 3 - Mapping to another 105S which is connected to a different 105U

In this example, both 105U modules act as repeaters. The first is a “serial-to-radio” repeater and the second is a “radio-to-serial” repeater.

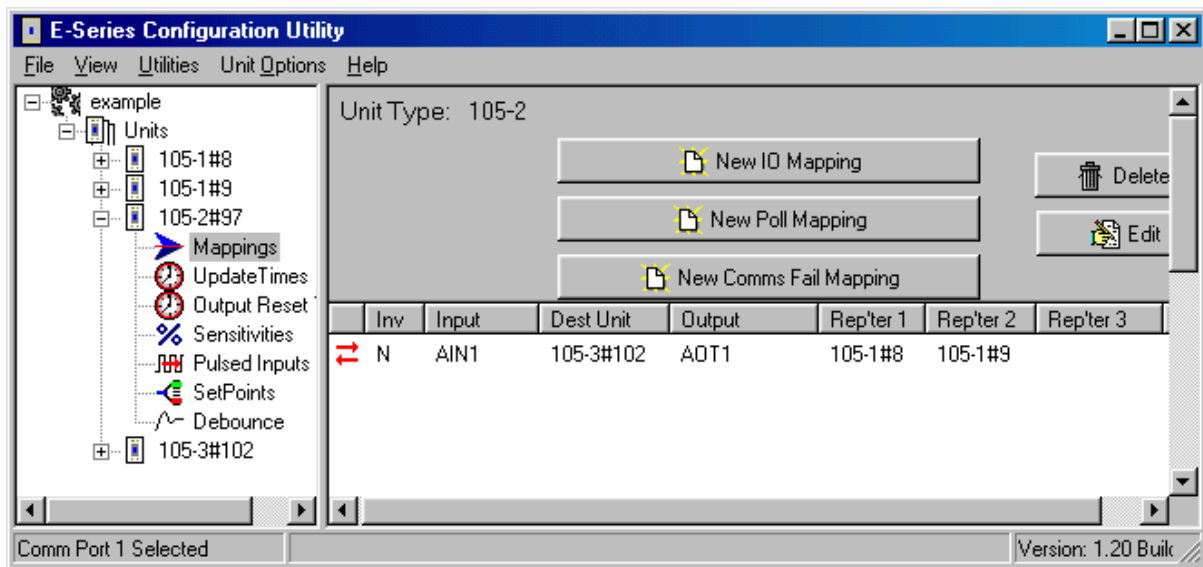
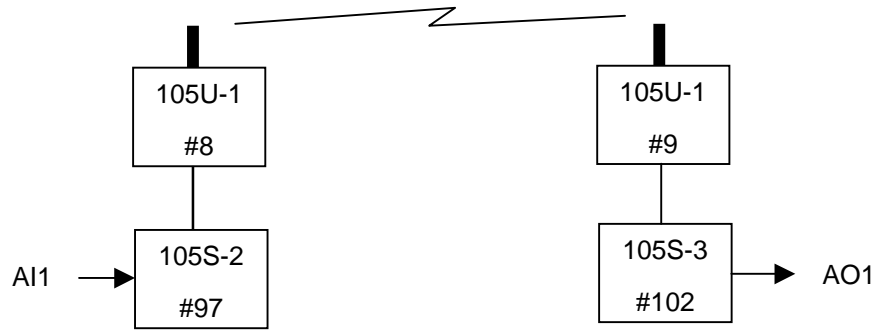

Chapter Five

SPECIFICATIONS

General		
EMC approval	EN55022 (CISPR 22) - CLASS B EN 50082-1 ETS 300 683 AS 3548	89/336/EEC
Radio standards 105U only	MPT 1329 UK EN-300-220 AS 4268.2 AUST RFS29 NZ	458 MHz, 500 mW EIRP 430 - 450 MHz, 10 - 500 mW 869 MHz, 500mW 472 MHz, 100 mW EIRP 458 MHz, 500 mW EIRP
Housing	130 x 185 x 60mm DIN rail mount	Powder-coated, extruded aluminium
Terminal blocks	Removable	Suitable for 2.5 mm ² conductors
LED indication	Power supply, OK operation, digital I/O, RX and TX	
Operating Temperature	-20 to 60 degrees C	
Power Supply		
Battery supply	11.3 - 15.0 VDC	
AC supply	12 - 24 VAC, 50/60 Hz	Overvoltage protected
DC supply	15 - 30 VDC	Overvoltage and reverse voltage protected
Mains supply	110-250 VAC	via plug-pack transformer
Battery Charging circuit	Included	for 1.2-12 ahr sealed lead acid battery
Solar regulator	Included	Direct connection of solar panel (up to 30W) and solar battery (100 Ahr)
Current Drain	70 mA quiescent for 'U' 45 mA quiescent for 'S'	+ 10 mA/active digital input + 25 mA/active digital output + 2 x analogue I/O loop (mA)
Radio transmitter inrush	400mA @ 13.8VDC 250mA @ 24VDC	500mW RF power
Analogue loop supply	Included, except 105-4	24V DC 150 mA
Mains fail status	Monitored	Can be transmitted to remote modules
Battery voltage	Monitored	As above

Radio Transceiver (105U)		
Single channel	synthesised	Direct frequency modulation
Frequency	405 - 490 Mhz 220 – 235MHz 869.4 – 869.65 MHz	12.5 kHz, 10 - 500 mW 25 kHz, 4W 250KHz, 500mW
Spurious emissions	RX - <-57 dBm TX - <-37 dBm	
Frequency Stability	+/- 1.0 kHz	
Receiver Sensitivity	0.4uV at 12dB SINAD	
Signal detect / RSSI	-120 to -80 dBm	
Expected line-of-sight range 400 – 500MHz	2 km @ 10mW EIRP 5 km @ 100mW EIRP 10 km @ 500 mW EIRP	Range may be extended by up to 5 intermediate modules as repeaters
Expected line-of-sight range 220 MHz	25 km @ 4W EIRP 40 km @ 10W EIRP	
Expected line-of-sight range 869 MHz	5 km @ 500mW EIRP	
Antenna Connector	Female coaxial	Protected by gas discharge surge arrester (but not the 869MHz model).
Serial Ports		
RS232 Port	DB9 female DCE	9600 baud, no parity, 8 data bits, 1 stop bit
RS485 Port	2 pin terminal block	9600 baud, no parity, 8 data bits, 1 stop bit, Typical distance 1km
Data transmission	On change-of-state + integrity update	Update time configurable
Protocol - serial - radio	asynchronous ARQ, with 16 bit CRC synchronous ARQ	Automatic acknowledgements with up to 4 retries
Communications fail status	May be mapped to local or remote output	Resetting of outputs on comms fail configurable

Inputs and Outputs		
Digital Inputs	105-1 Four 105-2 Four 105-3 None 105-4 Four plus 12 selectable I/O	Opto-isolated (5000V) inputs, suitable for voltage free contacts or NPN transistor, contact wetting current 5mA, input debounce 0.5 second As above, but with 3000V surge protection instead of opto-isolation
Digital Outputs	105-1 Four	Relay output contacts, normally open, AC1 5A 250V AC3 2A 250V, 5A 120V DC1 5A 30V, 5A 20V DC3 2A 30V, 5A 20V
Digital Outputs	105-2 One 105-3 Eight 105-4 Four plus 12 selectable I/O	FET output, 30 VDC 500mA max.
Pulse Inputs	105-1 One 105-2 Four 105-3 None 105-4 Four	Uses DI1. Max rate 100Hz, min. off-time 5msec. Uses DI1-4. Max rate of DI1 is 1000Hz, min. off-time 0.5msec Max rate of DI2-4 is 100Hz, min. off-time 5msec.
Pulse Output	105-1 One 105-2 None 105-3 Four 105-4 Four	FET output, 30 VDC 500mA max Max rate for 105-1 is 100 Hz. Max rate for 105-3 is 1000 Hz. Pulse signal recreated, pulse rate avail. on analogue output, (scaling configurable). Divide-by-10 available for 1000Hz inputs.
Analogue Inputs	“floating” differential input, common mode voltage -0.5V to 27V 105-1 Two 4-20 mA 105-2 Six 0-20mA 105-3, -4 None	24 VDC for powering external loops provided, 150 mA max, Digital filter time constant 1 second. Resolution 15 bit, Accuracy 0.1% Resolution 12 bit, Accuracy 0.1%
Analogue Input Setpoints	105-1 AI 1 only 105-2 AI 1-6	Configurable high & low set-points, allowing set/reset of remote digital outputs

Analogue Outputs	current sink to common 105-1 Two 4-20mA 105-2, -4 None 105-3 Eight 0-20mA	max loop voltage 27V, Resolution 15 bit, Accuracy 0.1% Resolution 15 bit, Accuracy 0.1%
System Parameters		
Network Configurations	Communications via radio or RS485 or network of both	Up to 95 radio units with up to 32 serial units off each radio unit
Mapping	Any input to any output in system	
User Configuration		RS232, PC or laptop
Diagnostics		
On board diagnostics	Automatic check on start-up Via RS232 terminal or laptop	Input status Output test Incoming radio signal level Simple radio path testing

Chapter Six TROUBLESHOOTING

6.1

Diagnostics Chart

INDICATOR	CONDITION	MEANING
OK LED OFF	Continuously	<ul style="list-style-type: none"> Battery Voltage low CPU failure +24V supply failure/overload
OK LED ON	Continuously	<ul style="list-style-type: none"> Normal Operation
PWR LED ON	Continuously	<ul style="list-style-type: none"> Supply available from SUP1/SUP2 Supply available from solar panel
TX LED ON	Flashes briefly	<ul style="list-style-type: none"> Radio transmitting
RX LED ON	Flashes briefly	<ul style="list-style-type: none"> Radio Receiving Serial port communicating
RX LED ON	Flashes continuously	<ul style="list-style-type: none"> Module in Configuration Mode
RX LED ON	Continuously	<ul style="list-style-type: none"> Test Button press in Configuration Mode
No transmission on change of state		<ul style="list-style-type: none"> Unit not configured correctly - re-configure and check operation

The green OK LED on the front panel indicates correct operation of the unit. This LED extinguishes on failure as described above. When the OK LED extinguishes shutdown state is indicated. In this state, all digital outputs turn OFF and the +24V supply turns off.

On processor failure, or on failure during start-up diagnostics, the unit shuts down, and remains in shutdown until the fault is rectified. The unit also shuts down if the battery voltage falls below 10.8 volts. This is a protection feature designed to protect the battery from deep discharge in case of extended period without supply voltage.

6.2

Self Test Functions

6.2.1 Input to Output Reflection (105-1 only)

The unit will require re-configuration after SELF TEST. Ensure you know the required operational configuration including system and unit addresses so that the network can be restored after testing.

Remove the cover in the front panel, and set the DIP switches as shown below. Hold down the red button for five seconds, or until the Rx LED glows yellow, release the Red button (the Rx LED now flashes), then press and release the Red button (the flashing Rx LED extinguishes).

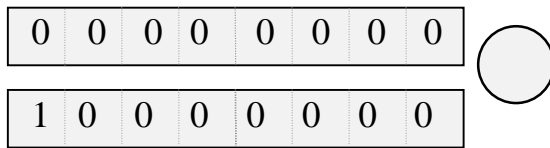

Input signals may now be connected to the input terminals of the module. If the module is operating correctly, then the input signals will be reflected to the corresponding output on the same module. For example, if DI 1 is connected to common - i.e. the first digital input is turned "ON" - then DO 1 will activate, if the module is functional. Similarly, if a 12mA signal is connected to AI 2, then a 12mA signal should be able to be measured from AO 2, if the module is functioning correctly.

If a module does not pass its self test function, then it should be returned to an authorised service agent for attention

6.2.2 Radio Testing using Tone Reversals

This function allows the unit to be configured to continuously transmit a sequence of alternate zeros and ones on the radio. This function provides the facility to check VSWR of antennas during installation, as well as checking the fade margin of the path between two units (see below - received signal strength indication).

The tone reversals function is initiated by setting all of the DIL switches to ON, and holding down the red button for approximately 5 seconds (until the RX LED lights continuously). On releasing the button, the RX LED will flash continuously, and the TX LED will light, indicating that the radio transmitter is on.

To finish the test, push the red button again or re-power the module.

6.2.3 Diagnostics menu

To aid in the checking and set-up of the 105 unit, a user friendly menu provides access to diagnostic functions in the 105. Use of the diagnostics menu does not affect module configuration. To access these diagnostics, a terminal must be connected to the serial port on the unit. The terminal may be a standalone terminal, or a personal computer running terminal emulation software such as Hyperterminal, which is supplied as part of MS Windows 95, 98, 2000, ME and NT (normally accessible through the Accessories / Communications menus).

Start Hyperterminal (Hypertrm.exe) and set up a "new connection" (call it "105U") - under the "Connect Using" prompt, select "Direct to COM1" or "Direct to COM2" depending on which COM port you will be using on the PC, then select the following Port Settings - 9600 baud, 8 data bits, no parity, 1 stop bit, no flow control. Save this connection for future use - this means that you won't have to set up the connection parameters for future uses.

Connect the module (ensure the RS485 port is disconnected first) to the PC using the same serial cable used for configuration. The diagnostics menu is accessed by setting all switches to '0', and holding down the red button for approximately 5 seconds, until the RX LED lights continuously. One of the following menus will be displayed on the terminal :

105 V1.0	1052 V1.0	1053 V1.0	1054 V1.0
a) Ins	a) Digital Ins	a) Ins	a) D Ins
b) Tones	b) Analog Ins	b) Tones	b) A Ins
c) Comms	c) Tones	c) Comms	c) Tones
d) DO1	d) Comms	d) DO1	d) Comms
e) DO2	e) DO1	e) DO2	e) DO1
f) DO3	f) Switch	f) DO3	f) DO2
g) DO4	g) Signal	g) DO4	g) DO3
h) AO1	>	h) DO5	h) DO4
i) AO2		i) DO6	i) DIO1
j) Switch		j) DO7	j) DIO2
k) Signal		k) DO8	k) DIO3
>		l) AO1	l) DIO4
		m) AO2	m) DIO5
		n) AO3	n) DIO6
		o) AO4	o) DIO7
		p) AO5	p) DIO8
		q) AO6	q) DIO9
		r) AO7	r) DIO10
		s) AO8	s) DIO11
		t) Switch	t) DIO12
		u) Signal	u) Signal
		>	>

Choose an item from the menu by entering the letter before that item. For example, to select the "Comms" function from the 105-2 Menu, enter :- d

Inputs

This option provides a dynamic display of the status of all of the inputs in the 105, both internal and external.

105-1 Modules

1234MLS	P CNT	AI1	AI2	P RATE	VBATT
0101001	00F6	C000	4000	8000	9C00

The first 7 values (1234MLS) each represent a single digital input. A '1' indicates that that input is ON, and a '0' indicates that the corresponding input is OFF. "1234" represents the four physical digital inputs, DI1 to DI4. "M" is the mains fail status ('1' for mains fail, '0' for mains OK). "L" is the battery low volts status ('1' for low volts '0' for OK). "S" is the set-point status.

P CNT, AI1, AI2, P RATE, and VBATT each represent 16 bit values, displayed as four hexadecimal digits.

P CNT is the current value of the pulsed input counter. This value should increment each time 'DI 1' turns from OFF to ON. P RATE displays the current pulse rate at DI1. This value is scaled according to the MAXRATE value configured (0 Hertz is displayed as 4000, and the maximum rate is displayed as C000).

AI1 and AI2 represent the value for the two analogue inputs. Full scale input (20 mA) is displayed as C000, 4mA is displayed as 4000, and 0mA is displayed as 2000. Analogue inputs are filtered digitally with a time constant of 1 second, so a sudden change in the analogue input current will result in a slower change in displayed analogue value, finally settling at the new value.

A guide to translate the displayed value to the analogue input current is provided below.

Add together the figures corresponding to each digit in each position to determine the current (mA) e.g. displayed value 3456 = 2.000+0.500+0.039+0.003 = 2.542mA				
Digit	Leftmost position	Next position	Next position	Rightmost position
0	-	0.000	0.000	0.000
1	-	0.125	0.008	0.000
2	0.000	0.250	0.016	0.001
3	2.000	0.375	0.023	0.001
4	4.000	0.500	0.031	0.002
5	6.000	0.625	0.039	0.002
6	8.000	0.750	0.047	0.003
7	10.000	0.875	0.055	0.003
8	12.000	1.000	0.063	0.004
9	14.000	1.125	0.070	0.004
A	16.000	1.250	0.078	0.005
B	18.000	1.375	0.086	0.005
C	20	1.500	0.094	0.006
D	22	1.625	0.102	0.006
E	-	1.750	0.109	0.007
F	-	1.875	0.117	0.007

VBATT is the current internally derived battery voltage. 4000 corresponds to 8 Volts, C000 represents 16 volts. A quicker method is use the calculation :

Battery voltage (volts) = $\frac{1}{2} I + 6$, where I is the mA value determined from the above table using VBATT. For example, a value of VBATT of A000 gives an I value of 16mA from the above table. The battery voltage corresponding to this is 14V (or $\frac{1}{2} \times 16 + 6$).

105-2 Modules

Digital Inputs

DIN	SETPNT	PULSED			
1234MSL123456		PIN1	PIN2	PIN3	PIN4
00001001111111		0000	0000	0000	0000

Analogue Inputs

VBAT	PR1	PR2	PR3	PR4	AI1	AI2	AI3	AI4	AI5	AI6
8138	4000	4000	4000	4000	0D3A	0CD2	0CC7	0CC7	0CD4	0CC7

105-3 Modules

ML VBAT VSLR

00 9FA2 0000

105-4 Modules**Digital Inputs**

DIN	DIO				PULSED
1234	123456789ABC	MLS	PIN1	PIN2	PIN3 PIN4
1001	010101010	001 101	0001	0001	0001 0001

Analogue Inputs

VBAT	PR1	PR2	PR3	PR4
8DBE	0000	0000	0000	0000

Tones

This provides the same function as described above in 6.2.2. Tone Reversals. This function may be used to check VSWR of antennas, and may be used in conjunction with the Signal option (described below) to check the path between two 105 units.

Comms

This function allows monitoring of all messages transmitted and received over the radio. Transmitted messages are displayed starting in the leftmost column of the display. Received messages are displayed indented by one space. Received messages which have been corrupted are displayed with a '*' in the first column of the display. The first four hexadecimal digits are the system address attached to the message, and must match for units to communicate successfully.

Example (105-1):

```
>c
```

```
Comms
```

01FA8106008005C6727D44	Command message transmitted by this unit.
*01FA8186C6E0E3	Corrupt Acknowledge received from remote.
01FA8106008005C6727D44	Message re-transmitted by this unit. (no Ack)
01FA818600E0E3	Valid Acknowledge received from remote.
*01FB860100800100009286	Corrupt message received from remote unit.
01FA860100800100009286	Re-sent message received from remote unit.
01FA868100FCE4	Acknowledge message from this unit to remote.

DO1 to DO8, DIO1 to DIO12

These options allow the user to set and clear digital outputs. To set an output, select the corresponding menu item, at the prompt, type the value FFFF to turn the output ON, or 0000 to turn the output OFF. For example, to set DO1 ON,

```
>e
```

```
DO1
```

```
>FFFF
```

AO1 to AO8

These options allow the user to set analogue outputs to any value. To set the output, select the corresponding menu item. At the prompt type the value required for the analogue output as a four digit hexadecimal value. Refer to the table above for analogue current/expected value relationship. To set AO2 on 105-3 to 19 mA :

```
>m
```

```
AO2
```

```
>B800
```

Switch

This option allows testing of the DIL (Dual In Line) switches. The diagram below indicates the layout of the switches of which there are two sets of eight, with an “Enter” button located to the right of the pair. the display indicates the current switch settings with the digit ‘1’ corresponding to ‘On’ and the digit ‘0’ corresponding to ‘Off’. Changing the switch settings in this mode will change the display. Test each switch and check to ensure the display changes accordingly.

Switches

1	1	1	0	0	0	1	0
0	1	0	1	0	1	0	1

Displayed

```
1110001001010101
```

Signal

This option provides for testing the radio path between two 105-U units for a suitable fade margin. Although a pair of units may communicate successfully, radio communication may be affected by a range of influences, including atmospheric conditions, changing landscape, degradation of antennas or co-axial cable, low battery voltage etc. Fade margin is an indication of how far a radio path can deteriorate before communication becomes unreliable.

When using the Signal feature, a meter is displayed with a mark indicating the current received radio signal level. To check the radio path between two units, select the signal option at the local unit. The remote unit may then be set up for tone reversals (refer 1 above) and the

signal level read from the meter.

A simpler method when remote units are not easily accessible is to cause a transmission from the local unit to the remote unit (by setting a digital input which maps to the remote unit, for example). The meter will latch the received signal from the remote unit for half a second, allowing the received level to be read.

Under normal radio conditions, a reading of 0 indicates a very marginal communication path. For reliable communications, the signal reading should be 3 or above.

>k Minimum signal level for reliable comms

Signal

0123456789----

#

In areas experiencing radio interference or high background noise, reliable communications may not be achievable even with this signal level. To determine if interference is occurring the signal option may be selected without any other 105 units active. In a normal radio environment, no reading should be displayed. If a reading is displayed, then **the received signal strength from the remote should be at least three counts higher than the background noise** for reliable communication.

>k Displayed signal level of
Signal background noise/interference

0123456789----

#

>k Minimum signal level for reliable comms

Signal

0123456789----

#

When using directional antennas (i.e. YAGI antennas) this feature may be used to peak the received signal level. Set-up the remote unit to transmit tone reversals as described above, and observe the signal indication while adjusting the orientation of the antenna. A peak in signal level indicates optimum orientation of the antenna.

Chapter Seven WARRANTY & SERVICE

We are pleased that you have purchased this product. Your purchase is guaranteed against defects for a 365 day warranty period, commencing from the date of purchase.

This warranty does not extend to:

- Failures caused by the operation of the equipment outside the particular product's specification.
- use of the 105 module not in accordance with this User Manual, or
- abuse, misuse, neglect or damage by external causes, or
- repairs, alterations, or modifications undertaken other than by an authorised Service Agent.

Full product specifications and maintenance instructions are available from your Service Agent, your source of purchase, or from the master distributor in your country upon request and should be noted if you are in any doubt about the operating environment for your equipment purchase

In the unlikely event of your purchase being faulty, your warranty extends to free repair or replacement of the faulty unit, after its receipt at the master distributor in your country. Our warranty does not include transport or insurance charges relating to a warranty claim.

This warranty does not indemnify the purchaser of products for any consequential claim for damages or loss of operations or profits.

Should you wish to make a warranty claim, or obtain service, please forward the module to the nearest authorised Service Agent along with proof of purchase. For details of authorised Service Agents, contact your sales distributor.

Appendix A SYSTEM EXAMPLE

The following example of a system is a comprehensive guide to using some of the features of the 105 range and design of 105 system.

The example application is a pump station which supplies water from a reservoir to a tank station. Signals are transferred between the pump station and tank station by radio - the distance between the two stations is 1.5 km (1 mile), and the radio path is heavily obstructed by buildings and trees. A control station is located near the pump station, and there is an existing signal cable between the control station and the pump station.

A 105U-1 module is installed at the pump station (with address 1) and a 105U-2 module is installed at the tank station (with address 2). Because the signal cable to the control station does not have enough cores for all of the signals required, the signal cable is used as a RS485 cable and a 105S-3 module is installed at the control station (with address 96). As this module has an address greater than 95, the 105U-1 at the pump station will communicate to it via its serial port.

The following diagram represents the system :-

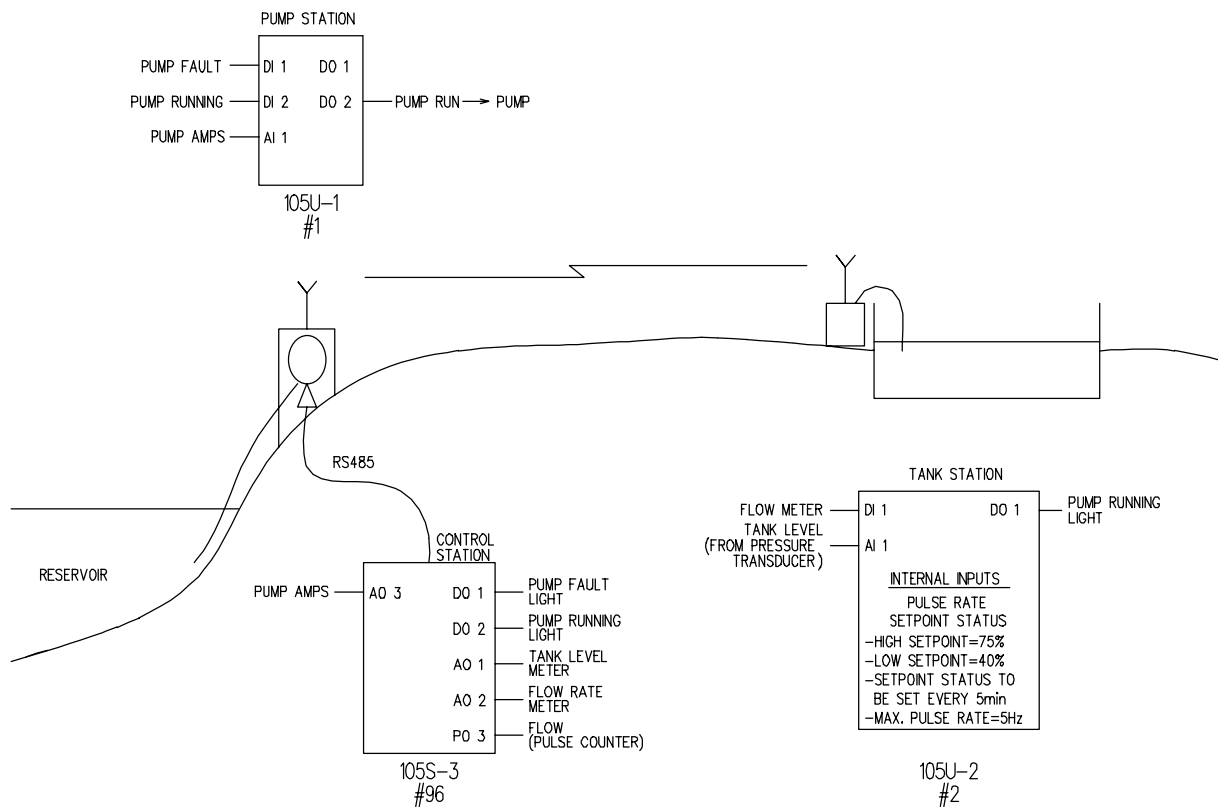

The following design points should be noted :-

- A test of the radio path between the pump station and the tank station indicated that the radio path would be reliable provided antennas were installed at 6 m above the ground. At each site, the coaxial cable would be approx 10 m in length, so it was decided to use 3 element Yagi antennas with RG58 coaxial cable - the Yagi antennas would compensate for the loss in the cable.

The system was installed in a country which permitted the use of 500mW radio power. If this had not been the case, then an intermediate repeater station would have been required.

- At the tank station, there was an existing light pole with a mains power supply - the light pole was 10m high. Permission was obtained to mount the antenna from the pole and to use the power supply for the radio telemetry module.

As there was no existing electrical panel at this station, a small steel enclosure was installed on the light pole. A 2 Amp-Hour sealed battery was installed to provide power during any mains failure. The flow and level transducer were powered from the 24VDC loop supply provided by the 105 module.

- At the pump station, the antenna was mounted on a 3 m J-bracket installed on the roof of the pump station building. The final height of the antenna was approx 6 m. Care was taken to align the Yagi antennas so they pointed at each other. The Yagi antennas were installed with horizontal polarity - that is, with the elements horizontal. These antennas will not "hear" other radio users on the same radio channel which generally use vertical polarity.

There was an existing electrical enclosure at the pump station, and the 105U module was installed inside this enclosure. The module was powered from 220VAC mains with a 2 Amp Hour sealed battery as backup.

- At the control station, the 105S module was installed inside the existing control panel enclosure. The module was powered from an existing 24VDC power supply.

Tank Station Configuration

The 105U-2 module has the following configuration :-

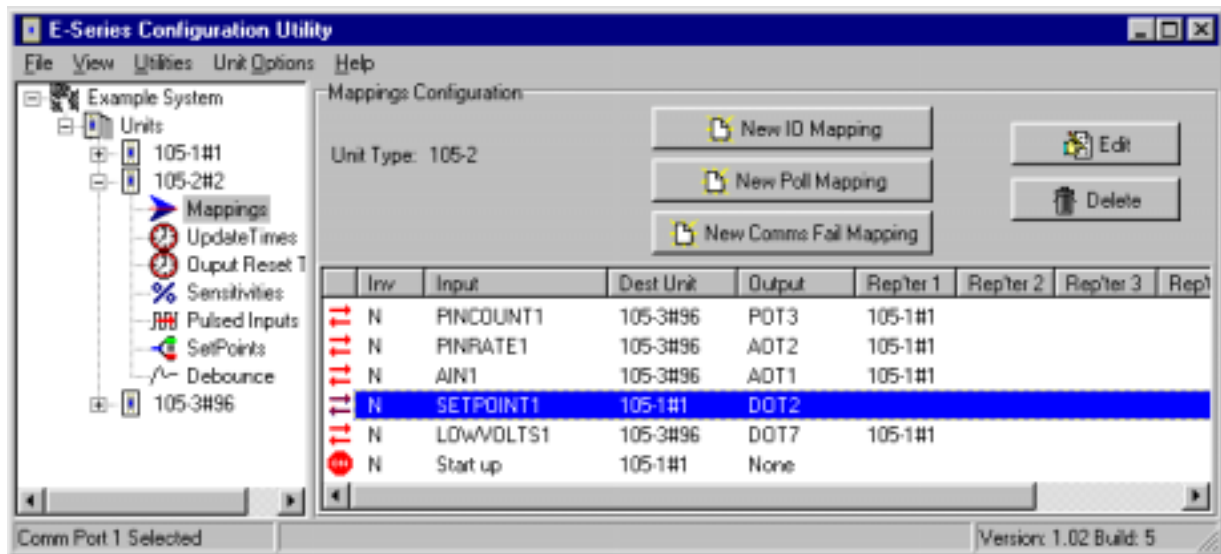

Note the following points in the configuration :

- #1 is a repeater for communications between #2 and #96
- The pulse rate scaling for PIN1 has been set to 5 Hz to match the maximum flow rate of the flow meter. Note that PIN1 has not been configured for "divide by 10" (for 1000 Hz pulse signals).
- AIN1 (the level transducer) is mapped to AO1 at the 105U-3. The analogue debounce has been set to 2 sec. This is because of concern of wave action on the surface of the tank causing un-necessary change transmissions. This debounce time will also operate on the Pulse Rate value, but as the flow rate changes slowly, this will not affect the performance of this signal.
- SETPOINT1 (the set-point status for AI1) is mapped to DO2 of #1 (pump station). The set-point values for this setpoint have been set to 40% and 75%. When the tank level drops to

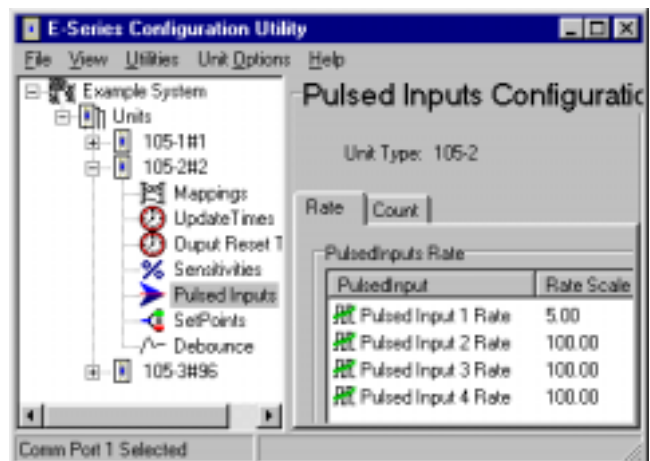
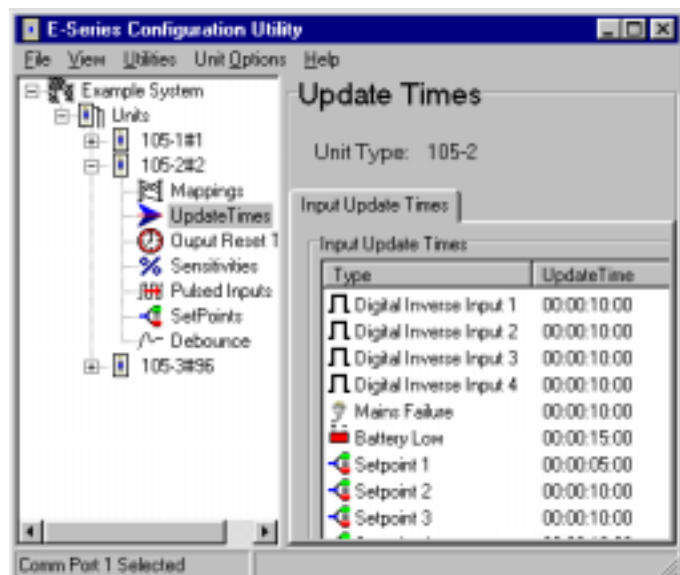

40%, DO2 at the pump station will activate to start the pump. When the level rises above 75%, DO2 will reset to stop the pump.

- The update time for SETPOINT1 has been changed to 5 minute, as required.
- An additional mapping has been entered - LOW VOLT has been mapped to DO7 at #96 via #1 (DO7 at the control station). This mapping is for future use - it will provide a low battery voltage alarm for the tank station. The update time for this mapping has been set to the maximum time of 15 minutes to reduce loading of the radio channel.
- A Start-up poll has been configured for #1, as DO1 at the tank station is controlled from the pump station. Note that no comms fail reset time has been configured for DO1. As this output drives an indication only, the indication will show the last correct status even during communication failures.

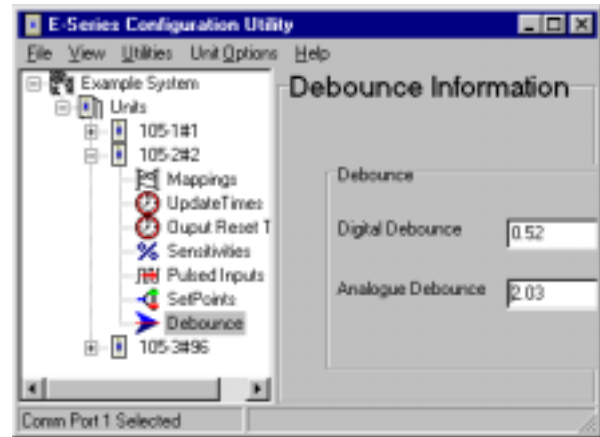

Pump Station Configuration

The 105U-1 module has the following configuration :-

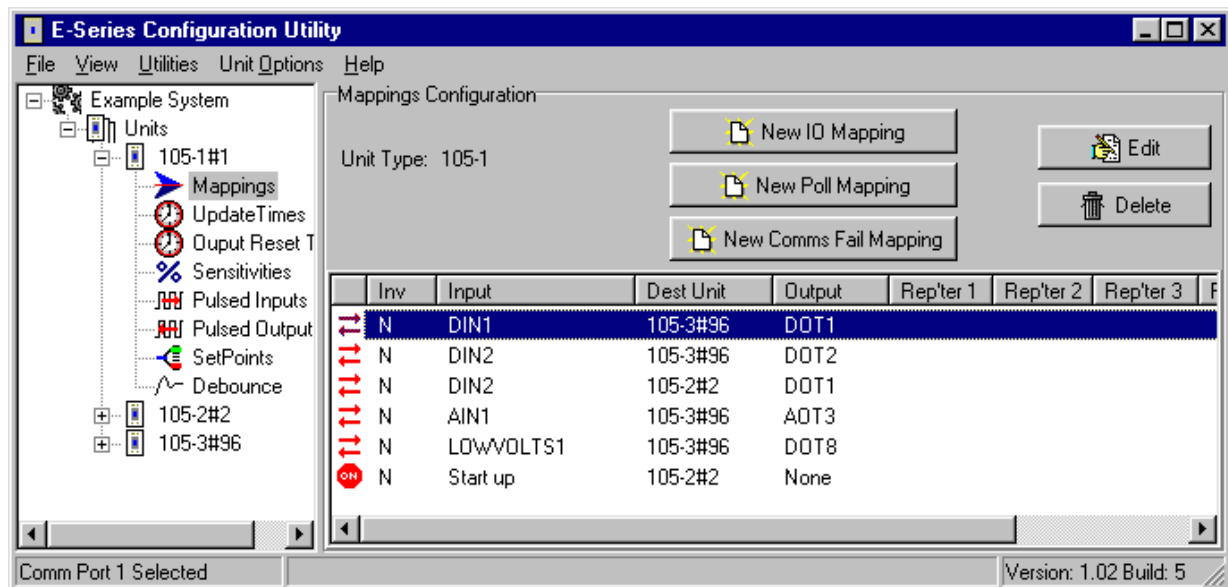

Note the following points in the configuration:

- Note that no repeater address is necessary between #1 and #96.
- DIN2 (pump running signal) has two mappings - a mapping to DO1 at #2 (tank station) and DO2 at #96 (control station). When DIN2 changes, there will be two separate change messages transmitted - one by radio to #2 and one by serial link to #96.

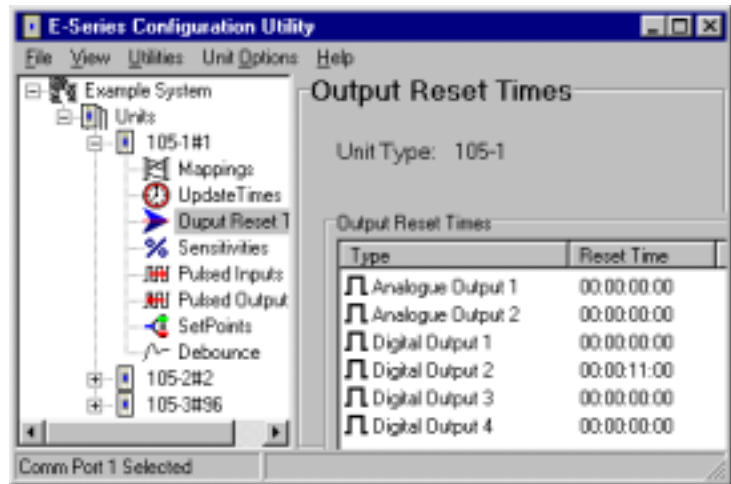

- AIN1 (pump amps) is mapped to AO3 at #97 (control station).
- An additional mapping has been entered - LOW VOLT has been mapped to DO8 at the control station. This mapping is for future use - it will provide a low battery voltage alarm for the pump station.
- A Start-up poll has been configured for #2, as DO2 at the pump station is controlled from the tank station. Note that a comms fail reset time of 11 minutes has been configured for DO2. This means that if a message has not been received for DO2 within 11 minutes, DO2 will reset and switch off the pump. The 11 min time was chosen as it means that two successive update messages have to be missed before the pump is reset, and there is no problems if the pump runs for 11 minutes during a system failure (the tank will not overflow during this time).

Control Station Configuration

The 105S-3 module has the following configuration :-

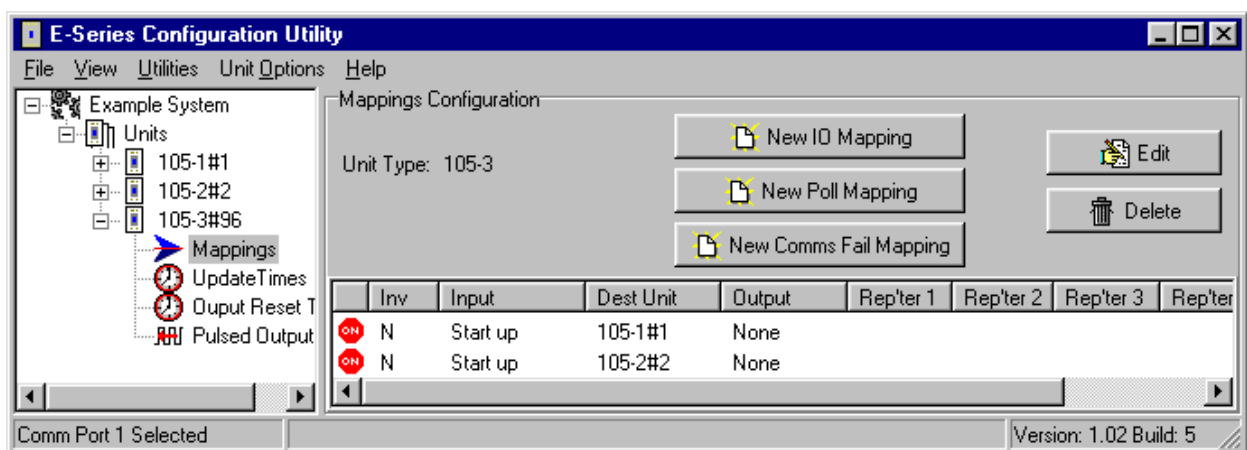

Note the following points in the configuration :

- The only mappings are Start-up polls. Note that there are two separate polls, one for each remote module.
- PO 3 has been configured as a PO. Its pulse output update time is the same as the PI

update time at the remote module (both have been left at their default value of 1 minute).

- Reset times have been selected for the analogue outputs (21 minutes) but not the digital outputs. In the event of a system failure, the digital outputs will stay at their last correct status, but the analogue outputs will reset to 0 mA.

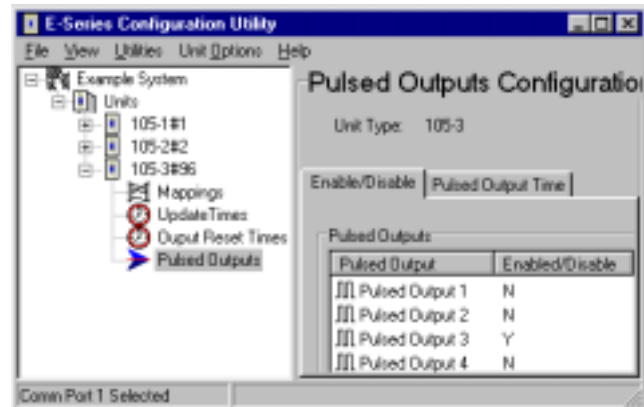

System Failure Alarm

After the system had been running for some time, the operators wanted a "system failure" output at the control station, to warn the operators that there was a fault with the system.

The following configuration was added:

At #2 (tank station), Inverse DI4 → DO4 at #96 via 1 ; DI4 Update time = 1 minute

At #96 (control station), DO4 Comms fail reset time = 3.5 min

At the control station, DO4 was a "system OK" signal. It was normally active - if the signal reset, then this represented a system failure. At the tank station, there is no signal wired to DI4. By mapping Inv DI4 to DO4 at the control station, a message is transmitted every minute to this output to activate it. The message is transmitted via the radio link to #1, and then by the serial link to #96. If anything happened to either module #2 or module #1, or the radio link, or the serial link, then the update messages for DO4 will not be received at the control station module. After 3.5 Minutes, DO4 will reset indicating a problem.

The time of 3.5 minutes was selected as this means that 3 successive update messages have to be missed before a system alarm occurs. Also note, that if module #96 fails, DO4 will reset and give an alarm signal.

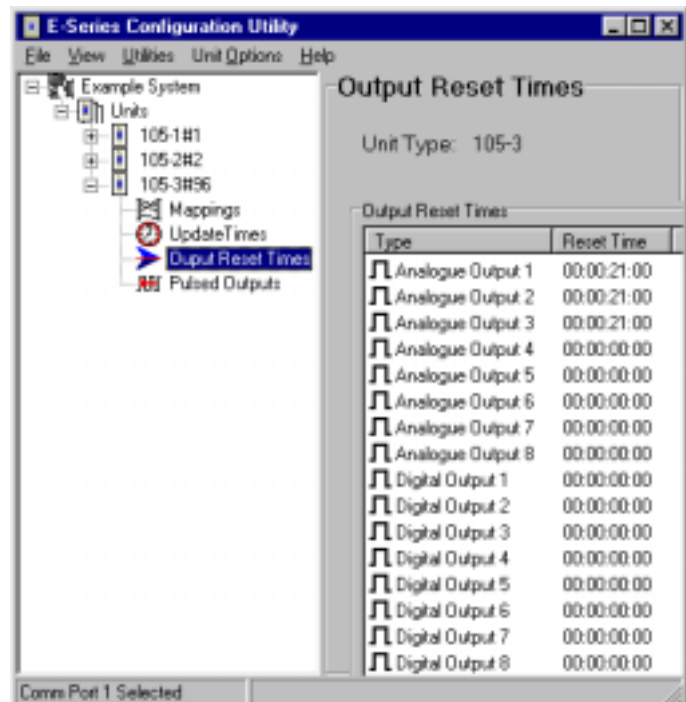

Appendix B TERMINAL LAYOUTS

WIRING DRAWING - 105U-1, 905U-1 105S-1

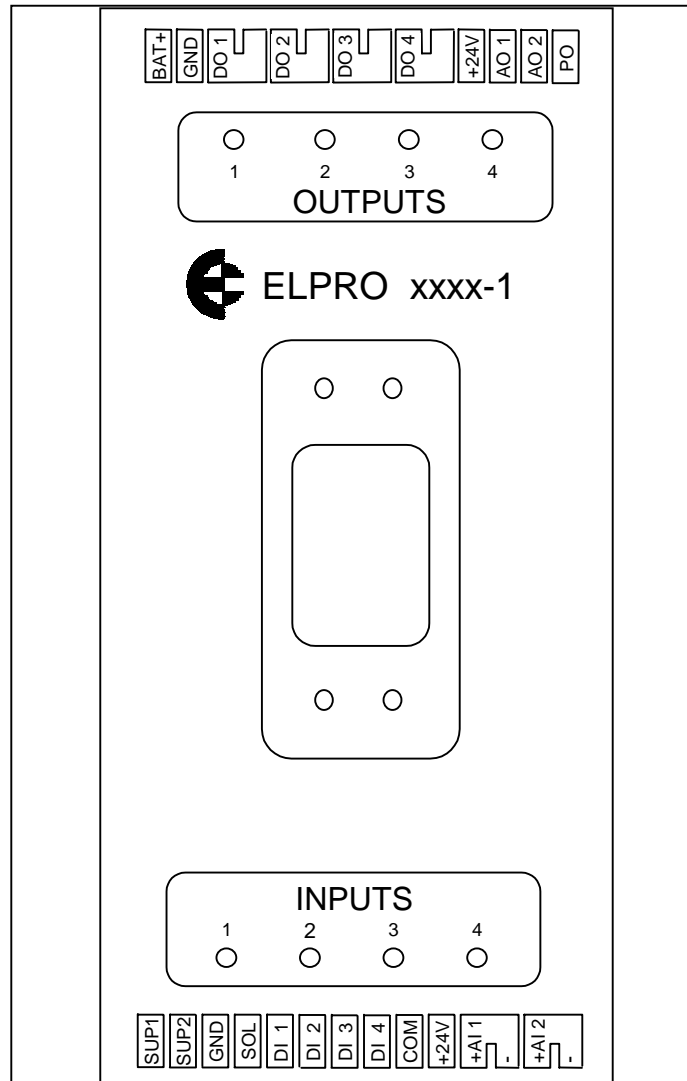

WIRING DRAWING - 105U-2, 905U-2 105S-2

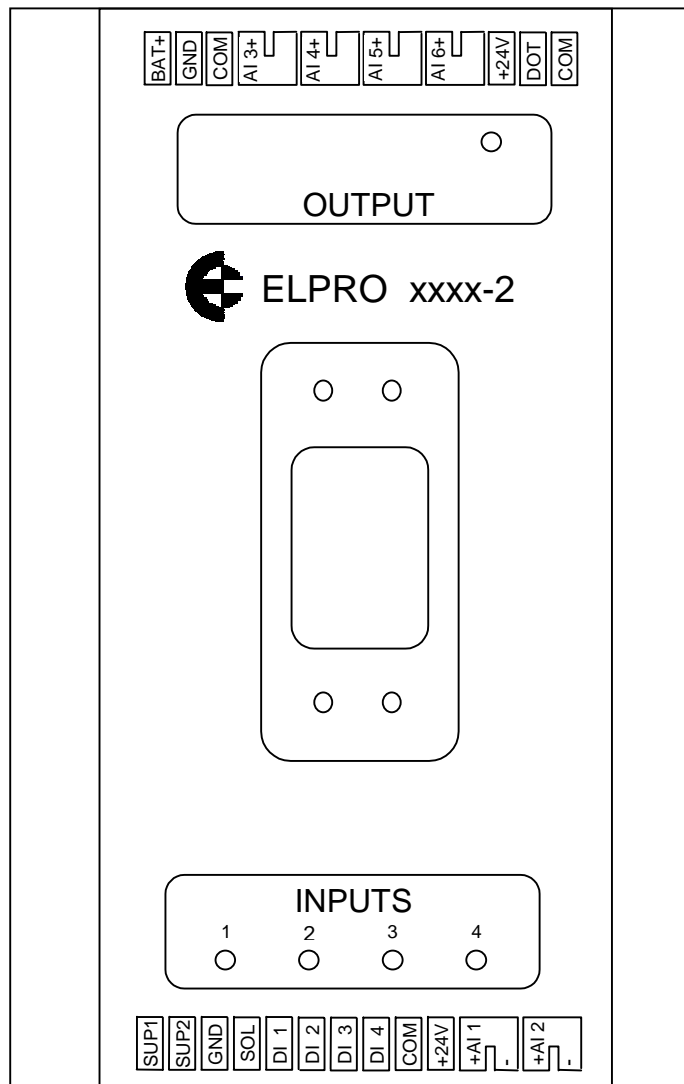

WIRING DRAWING - 105U-3, 905U-3, 105S-3

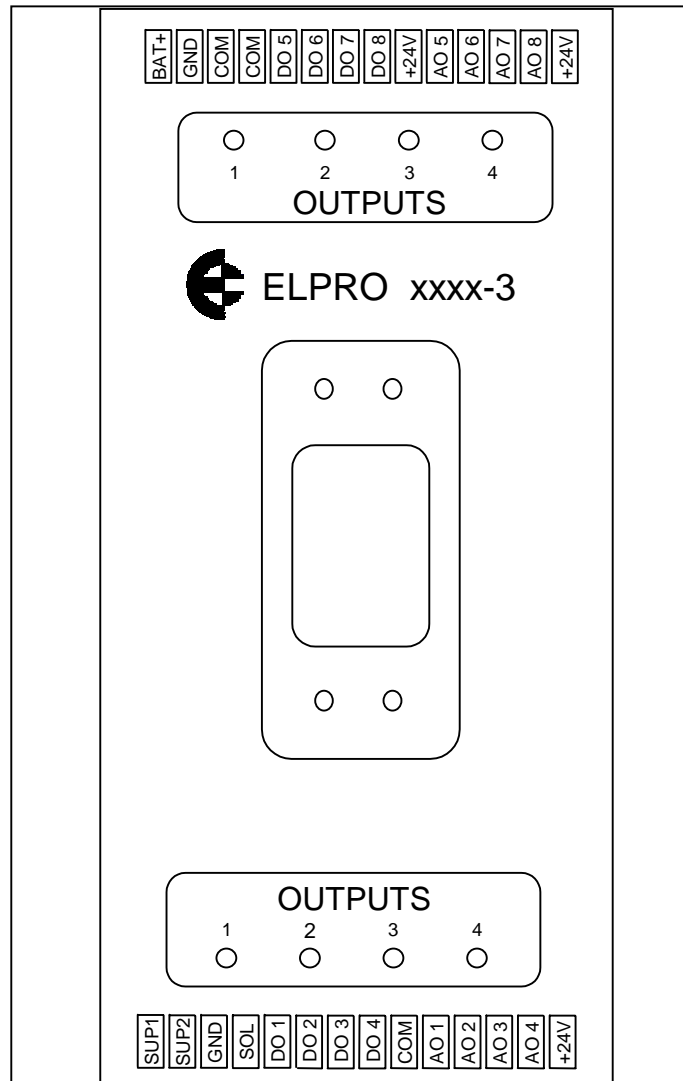

WIRING DRAWING - 105U-4, 905U-4, 105S-4

