

# Batch Controller

Model 414

## Features

- Dual relay outputs
- Overrun compensation
- Remote start/stop
- No-signal alarm
- Ticket printing with time and date
- Displays batch total, preset quantity, flow rate, and accumulated total



## Overview

The 414 Batch Controller is suited to flow applications where precise measurement and control of batch quantities is required. *Batch total, flow rate, accumulated total and preset value* can all be displayed in engineering units on the large LCD display.

The 414 will interface to most flowmeters with versions available for pulse and analog inputs.

## Batch Features

### Automatic Overrun Compensation

Based on previous batches, the 414 will automatically compensate for any overrun which may be caused by slow closing valves.

### Batch Limit

A maximum batch quantity can be programmed during set-up, so that the operator cannot enter a batch size that exceeds this limit.

### Signal Time-out

If the flow signal cuts out midway through a batch, the output relays are de-energised, and an alarm signalled via an open collector output.

### Remote Start/Stop

Remote push-button switches can be connected to the rear terminal strip, to start and stop batches.

### Auto Restart

The 414 can be programmed to automatically restart the batch after a preset time delay.

### Count Up/Down

The instrument can be programmed to count up from zero, or to count down from the batch quantity.

### End of Batch

An End of Batch signal is provided via an open collector transistor output.

# Batch Controller

## Model 414

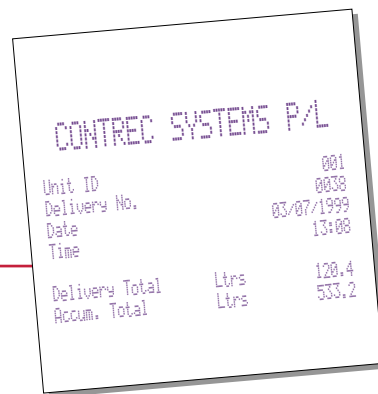

### Models Available

#### Model 414A

Analog input version with both linear and square law input relationships.

#### Model 414B

Frequency input version that will accept pulse and open collector inputs from opto-sensors or Hall effect devices.

#### Model 414D

Frequency input version with an input conditioning card capable of accepting mV signals from coils, 2-wire proximity sensors, reed switch inputs and most other pulse type signals.

#### Model 414H

For applications where batches are very short (<15 seconds) the 414H features a response time of less than 20ms.

The input is identical to the 414D but the scaling factor is limited to 4000 and the input frequency range is limited to 8kHz.

#### Model 414Q

Quadrature input version where the flowmeter produces two pulse or square wave signals 90° out of phase. Through the phasing of signals, forward and reverse flow can be detected.

#### Model 414LA

4-20mA temperature input version with temperature correction for general chemicals, petroleum to API tables and LPG (see separate data sheet).

#### Model 414LR

RTD temperature input version with temperature correction for general chemicals, petroleum to API tables and LPG (see separate data sheet).

### Operation

Four key switches on the front facia, enable the batch quantity to be set, and batch operations to be started, stopped or reset.

To set a batch quantity, the **BATCH SET** key is pressed, and then the  $\triangleright$  and  $\triangleleft$  keys can be used to change and increment digits. Once set, the **BATCH SET** key is again pressed to return to Run mode.

Keypad operations are straight forward and four LED's indicate the operational status at all times.

In Run mode, the **DISPLAY** key can be used to display flow rate, batch and accumulated total.

The unique four key function simplifies operation, making the instrument suited to use by operators with minimal training.

#### Versatile performance options

The instrument will operate from 12 to 28V dc or from 100/110/220V ac mains.

The facia is fully watertight to IP65 (Nema 4X) and is resistant to most chemicals.

The standard instrument is supplied as panel mount. Field enclosures and explosionproof enclosures are optionally available.

### Computer/Printer Interface

An RS232 and RS422/485 option is available for interfacing to computers and printers. The interface allows the Batch Controller to be fully controlled from a computer via an ASCII protocol.

Software drivers are included for a number of printers and can print a ticket with time and date, a sequential delivery/batch number and the batch and accumulated totals. An optional header for the ticket can also be printed.

### One or two stage valve control

Two output relays provide control for single or dual stage valve operation.

The first relay will energise at the start of the batch, and de-energise when the batch is complete.

The second relay can be programmed to energise at a set time after the start, and to de-energise at a set quantity prior to completion of the batch. This feature enables a slow startup and slow shutdown of the flow.

The Batch Controller can also be programmed to count up from zero or down from the Batch quantity.

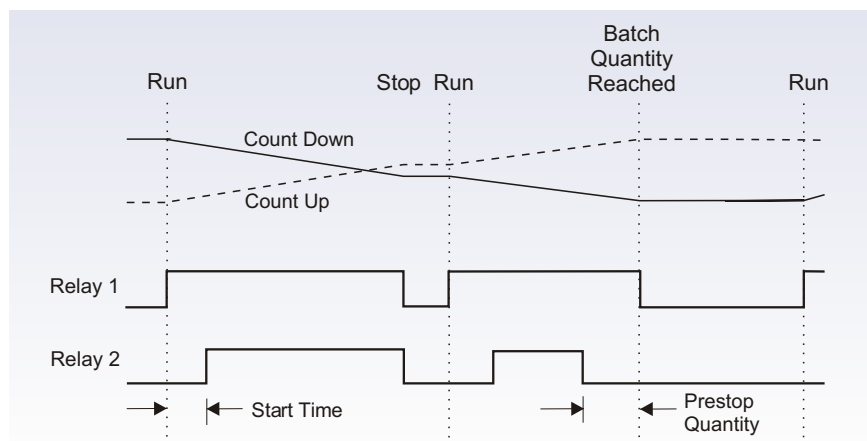

## General

<b>Display</b>	6 digit 0.7" (17.8mm) high LCD.
<b>Display Update Rate</b>	0.25s.
<b>Data Retention</b>	All set-up parameters and totals are stored in a non-volatile memory with 10 years retention.
<b>Pulse Output</b>	Open collector output with a 10ms pulse produced on each increment of the accumulated total.
<b>Max Output:</b>	49 pulses per second.
<b>Max Current:</b>	100mA.
<b>Transducer Supply</b>	8-24V dc field adjustable, 50mA maximum.
<b>Relays</b>	
Max Power:	1250VA.
Max Voltage:	250V ac, 30V dc.
Max Current:	5 Amps.
<b>Power Requirements</b>	
dc Supply:	11.5-28.5V dc, 200mA typical current (no options).
ac Supply:	ac mains set internally to 95-135V ac or 190-260V ac.
<b>Operating Temperature</b>	0 to 55°C.

## Approvals

<b>Electrical</b>	ETL (US) approved to UL 508 and CSA.
<b>Interference</b>	CE Compliance.
<b>Enclosures</b>	CENELEC, FM, CSA and SAA approved enclosures available for hazardous areas.

## Frequency Input Models

<b>Frequency Range</b>	
Minimum:	0.25Hz on Rate, 0Hz on Total.
Maximum:	10kHz (except 414H which is 8kHz).
<b>Scaling Range</b>	
	0.1000 to 50,000.
	0.1000 to 4,000 (414H).

## Analog Input (Model 414A)

<b>Inputs</b>	Isolated 4-20mA, 0-20mA & 0-10V.
<b>Input Impedance</b>	
Current:	250 ohms.
Voltage:	10K ohms.
<b>Accuracy</b>	0.075%.
<b>Span</b>	0.1000 to 50,000.
<b>Cutoff Point</b>	A low flow rate cutoff can be programmed below which flow is not registered. The cutoff is programmed as a percentage of span.
<b>Relationship</b>	Linear, square root or programmable power between 0 and 9.99.

## Optional Enclosures

<b>Field Enclosures</b>	IP65 (Nema 4X).
<b>Explosionproof Enclosures</b>	

*Important: Specifications are subject to change without notice.*

## Dimension Drawings

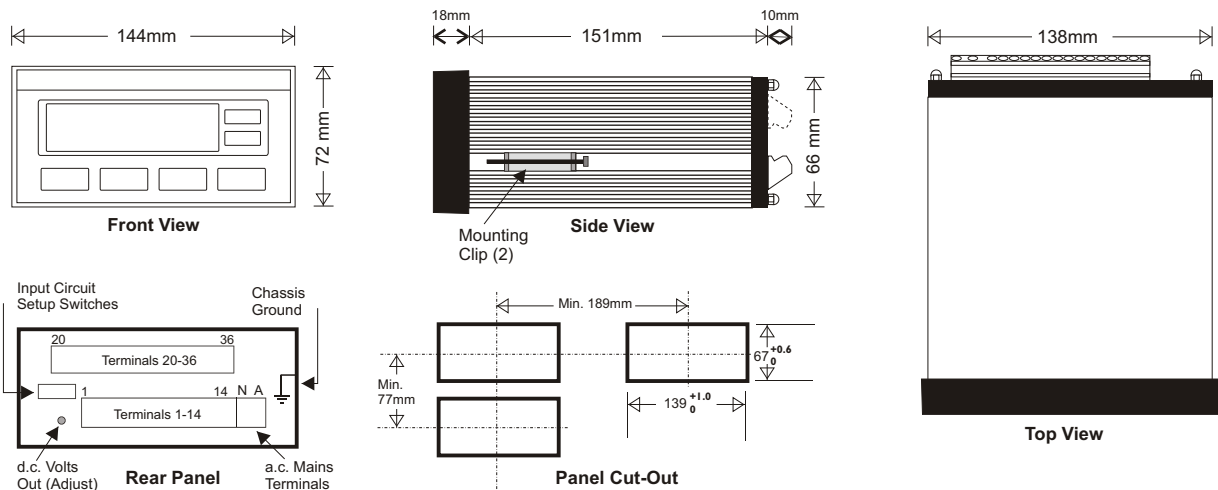

## Terminal Descriptions

Terminals Common to all Models	
No.	
1	Calibration
2	Switch Common
11	DC Power Out
12	DC Ground
13	DC Power In
28	Remote Run Switch

RS232/422 Option (All Models)	
No.	
20	RS232 Signal Ground
21	RS232 Data In
22	RS232 Data Out
23	RS422 (-) Data Out
24	RS422 (+) Data Out
25	RS422 (-) Data In
26	RS422 (+) Data In
27	RS232 CTS

No.	
29	Remote Stop Switch
30	End of Batch Signal
31	Relay 2 Normally Open
32	Relay 2 Normally Closed
33	Relay 2 Common
34	Relay 1 Normally Open
35	Relay 1 Normally Closed
36	Relay 1 Common

### Terminals specific to each Model

No.	414A	414B	414D 414H	414LA	414LR	414Q	No.
3	Not Used	Not Used	Not Used	Flow Input Ch. 2	Flow Input Ch. 2	Flow Input Ch. 2	3
4	Display Switch	Not Used	Display Switch	Not Used	PT100 (+)	Not Used	4
5	Batch Set Switch	Not Used	Batch Set Switch	Temp (4-20mA)	PT100 Signal (+)	Not Used	5
6	Not Used	Not Used	Not Used	Not Used	PT100 Signal (-)	Not Used	6
7	Flow Alarm	Not Used	Flow Alarm	Flow Alarm	Flow Alarm	Flow Alarm	7
8	Flow Common	Flow Common	Flow Common	Flow Common	Flow Common	Flow Common	8
9	Flow Signal (mA)	Flow Signal	Flow Signal	Flow Input Ch. 1	Flow Input Ch. 1	Flow Input Ch. 1	9
10	Pulse Out	Not Used	Pulse Out	Pulse Out	Pulse Out	Pulse Out	10
14	Flow Signal (Volts)	Not Used	Not Used	Flow Input (4-20mA)	PT100 (-)	Not Used	14

## Ordering Information

When specifying please indicate model(s) required using the following method.

414 D . 1 0 E 0

<p><b>Basic Model</b></p> <p><b>Type of Input</b></p> <p>Analog Input - A</p> <p>Pulse Input - B</p> <p>Pulse or frequency input with signal conditioner - D</p> <p>High speed response (pulse or frequency) - H</p> <p>Quadrature pulse - Q</p> <p>Temperature Compensation (4-20mA) - LA</p> <p>Temperature Compensation (RTD) - LR</p>		<p><b>Special Options</b></p> <p>0 - No option</p> <p>B - Backlighting</p> <p>C - Conformal Coating</p> <p><b>Power Supply</b></p> <p>E - 220-240V ac</p> <p>A - 110-120V ac</p> <p>D - 12-28V dc</p> <p>J - 100V ac</p> <p><b>Communications</b></p> <p>0 - No option</p> <p>2 - RS232/422</p> <p><b>Mounting Options</b></p> <p>1 - Panel mount</p> <p>N - Field mount enclosure</p> <p>3 - Explosionproof enclosure</p>
---	--	--