

Series VBR; with integrated overflow valve and bypass

1.3

Technical selection chart: scaled drawings

Direction of rotation viewed from shaft
I = indirect – counterclockwise
D = direct – clockwise

The direction of rotation can only be changed in the factory. Therefore please assure that you state the desired direction of rotation as per the size chart/sheet when ordering!

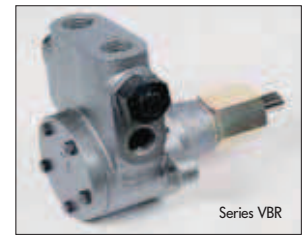

hp-Internal gear pumps up to 40 bar (direction **I** = indirect – counterclockwise)

Pump series VBR	Viscosity: 6 mm ² sec ⁻¹ bei 20 °C								Gear rotor size Ø	Shaft Ø	Threaded connection for (S/A/R)	Manometer connection	Max. allowed pump RPM (min ⁻¹)	Net weight (kg)
	n = 1400 min ⁻¹ Discharge l/h				n = 2800 min ⁻¹ Discharge l/h									
	at 9 bar	at 30 bar	at 40 bar	Article-no. I	at 9 bar	at 30 bar	at 40 bar	Article-no. I						
VBR P	45	30	20	011/0011	90	60	50	013/0011	25	12	3/8"	-	2800	2,5
VBR M	80	60	50	011/0012	160	130	120	013/0012	25	12	3/8"	-	2800	2,5
VBR G	120	100	80	011/0013	240	200	190	013/0013	25	12	3/8"	-	2800	2,5
VBR F	160	140	120	011/0014	320	270	260	013/0014	25	12	3/8"	-	2800	2,5
VBGR PP	150	100	80	011/0065	300	240	210	013/0040	38	12	1/2"	-	2800	3,3
VBGR PZ	200	160	140	011/0062	400	310	280	013/0041	38	12	1/2"	-	2800	3,3
VBGR P	300	240	200	011/0025	600	520	480	013/0023	38	12	1/2"	-	2800	3,3
VBGR MZ	-	-	-	-	850	750	700	013/0072	38	12	1/2"	-	2800	3,3
VBGR M	450	390	360	011/0026	900	850	730	013/0024	38	12	1/2"	-	2800	3,3
VBGR GZ	-	-	-	-	1100	1000	870	013/0042	38	12	1/2"	-	2800	3,3
VBGR G	600	540	480	011/0027	1200	1080	960	013/0043	38	12	1/2"	-	1680	3,3
VBHR P	1000	700	600	011/0037	-	-	-	-	56	18	3/4"	1/8"	1680	7,3
VBHR M	1500	1200	1000	011/0038	-	-	-	-	56	18	3/4"	1/8"	1680	7,3
VBHR G	2000	1700	1400	011/0039	-	-	-	-	56	18	3/4"	1/8"	1680	7,3
VBHGR P	3000	2200	2000	011/0049	-	-	-	-	75	22	1"	1/4"	1400	18,6
VBHGR PZ	3700	3000	2700	011/0090	-	-	-	-	75	22	1"	1/4"	1400	18,6
VBHGR M	4500	3600	3200	011/0050	-	-	-	-	75	22	1"	1/4"	1400	18,6
VBHGR G	6000	4800	-	011/0051	-	-	-	-	75	22	1"	1/4"	1400	18,6

hp-Internal gear pumps up to 40 bar (direction **D** = direct – clockwise)

Pump series VBR	Viscosity: 6 mm ² sec ⁻¹ bei 20 °C								Gear rotor size Ø	Shaft Ø	Threaded connection for (S/A/R)	Manometer connection	Heating capacity H1 in Watt at 220V, 50Hz	Initial pump breakaway torque
	n = 1400 min ⁻¹ Discharge l/h				n = 2800 min ⁻¹ Discharge l/h									
	at 9 bar	at 30 bar	at 40 bar	Article-no. I	at 9 bar	at 30 bar	at 40 bar	Article-no. I						
VBR P	45	30	20	012/0011	90	60	50	014/0011	25	12	3/8"	-	100	1,2
VBR M	80	60	50	012/0012	160	130	120	014/0012	25	12	3/8"	-	100	1,2
VBR G	120	100	80	012/0013	240	200	190	014/0013	25	12	3/8"	-	100	1,2
VBR F	160	140	120	012/0014	320	270	260	014/0014	25	12	3/8"	-	100	1,2
VBGR PP	150	100	80	012/0065	300	240	210	014/0040	38	12	1/2"	-	100	1,6
VBGR PZ	200	160	140	012/0062	400	310	280	014/0041	38	12	1/2"	-	100	1,6
VBGR P	300	240	200	012/0025	600	520	480	014/0023	38	12	1/2"	-	100	1,6
VBGR MZ	-	-	-	-	850	750	700	014/0072	38	12	1/2"	-	100	1,6
VBGR M	450	390	360	012/0026	900	850	730	014/0024	38	12	1/2"	-	100	1,6
VBGR GZ	-	-	-	-	1100	1000	870	014/0042	38	12	1/2"	-	100	1,6
VBGR G	600	540	480	012/0027	1200	1080	960	014/0043	38	12	1/2"	-	100	1,6
VBHR P	1000	700	600	012/0037	-	-	-	-	56	18	3/4"	1/8"	160	3,2
VBHR M	1500	1200	1000	012/0038	-	-	-	-	56	18	3/4"	1/8"	160	3,2
VBHR G	2000	1700	1400	012/0039	-	-	-	-	56	18	3/4"	1/8"	160	3,2
VBHGR P	3000	2200	2000	012/0049	-	-	-	-	75	22	1"	1/4"	280	4,6
VBHGR PZ	3700	3000	2700	012/0090	-	-	-	-	75	22	1"	1/4"	280	4,6
VBHGR M	4500	3600	3200	012/0050	-	-	-	-	75	22	1"	1/4"	280	4,6
VBHGR G	6000	4800	-	012/0051	-	-	-	-	75	22	1"	1/4"	280	4,6

* To insure proper pump functioning, all pipe connections must be sized as per the principles of fluid technology using the phase quantity and in accordance with the given conditions at the installation site!
 The size of the pump and/or device connections is not indicative of the size of the pipe connection which must be used.

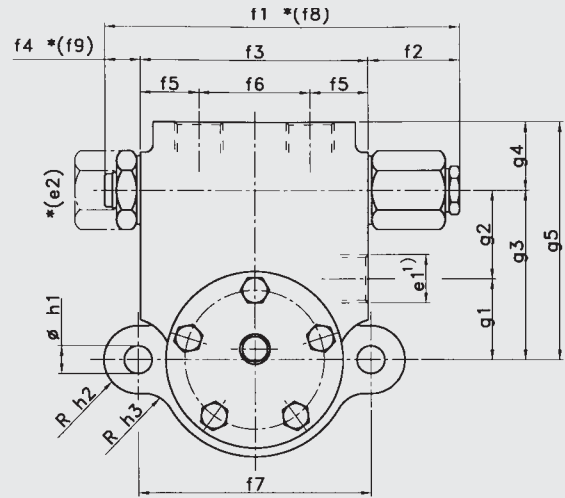
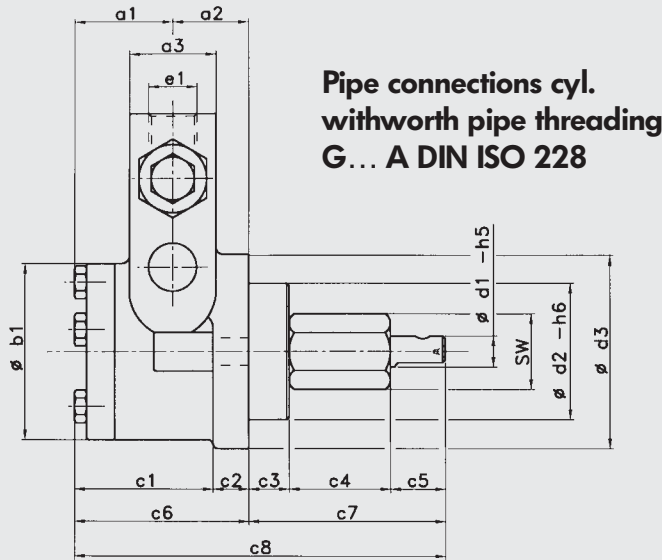

Special model:
* with SC quick-close
* e2 nozzle connection

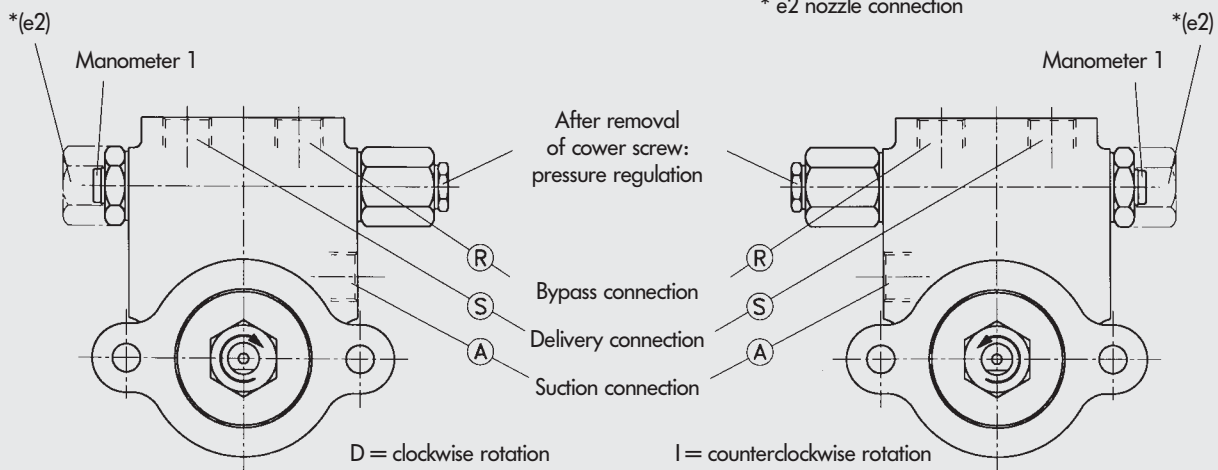

Model	Discharge l/h		a1	a2	a3	b1	c1	c2	c3	c4	c5	c6	c7	c8
	1400 min ⁻¹	2800 min ⁻¹												
25	45 - 160	90 - 320	35,5	20	33	51	41,5	14	16	40	20	55,5	76	131,5
38	150 - 600	300 - 1200	39,5	30	38	70	55,5	14	16	40	20	69,5	76	145,5
56	1000 - 2000	-	48,5	38	45	96	71,5	15	18	79	27	86,5	124	210,5
75	3000 - 6000	-	62,5	85	70	115	129,5	18	25	65	37	147,5	127	274,5

Model	Discharge l/h		d1	sw	e	d2	d3	e1	*e2	f1	f2	f3	f4	f5
	1400 min ⁻¹	2800 min ⁻¹												
25	45 - 160	90 - 320	12	27	31,2	54	80	G 3/8"	G 3/8"	139	32	90	17	26
38	150 - 600	300 - 1200	12	27	31,2	54	80	G 1/2"	G 3/8"	139	32	90	17	23
56	1000 - 2000	-	18	46	53	60	100	G 3/4"	G 3/8"	162	26,5	118	17,5	25,5
75	3000 - 6000	-	22	55	63,5	80	120	G 1"	G 3/8"	211	36	150	25	35

Model	Discharge l/h		f6	f7	f8	f9	g1	g2	g3	g4	g5	h1	h2	h3
	1400 min ⁻¹	2800 min ⁻¹												
25	45 - 160	90 - 320	38	92	140	18	30	33	63	27	90	11	13	13
38	150 - 600	300 - 1200	44	92	140	18	32	35	67	27	94	11	13	13
56	1000 - 2000	-	67	120	171	26,5	38	42	80	35	115	13	13	25
75	3000 - 6000	-	80	150	218	32	18	62	80	40	120	14,5	15	-

VBHGR model with G 1/4" manometer connection at the face.

1) Given a motive force of 75 = 3000 to 6000 l/h, the suction connection at the side is G1 1/2".