

DIFFERENTIAL FLOW COMPUTER

WITH TEMPERATURE COMPENSATION FOR CORRECTED LIQUID VOLUME



Features

- Displays compensated consumption (flowrate), total and accumulated total.
- Supply line: displays temperature and compensated flowrate.
- Return line: displays temperature and compensated flowrate.
- 7 digit resettable total.
- 11 digit accumulated total.
- Analog signal output.
- Very compact design for panel mount, wall mount or field mount applications.
- Operational temperature -30°C up to +80°C (-22°F up to 178°F).
- Rugged aluminum field mount enclosure IP67/NEMA4X.
- Intrinsically Safe
⊕ II 1 GD EEx ia IIB/IIC T4 T100°C.
- Explosion/flame proof ⊕ II 2 GD EEx d IIB T5.
- Full Modbus communication RS232 / 485 / TTL.
- Loop or battery powered, 8 - 24V AC/DC or 115 - 230V AC power supply.
- Sensor supply 3.2 - 8.2 - 12 - 24V DC.

Signal output

- (0)4 - 20mA / 0 - 10V DC according to compensated consumption (flowrate).

Signal input

Flow

- Reed-switch.
- NAMUR.
- NPN/PNP pulse.
- Sine wave (coil).
- Active pulse signals.

Temperature

- PT100 - 2 or 3 wire.
- (0)4 - 20mA.
- 0 - 10V DC.

Applications

- fuel consumption calculation for diesel engines on board of ships or locomotives, generators or burners. Alternative basic model: F116.

General information

Introduction

The flowcomputer Model F127 has been developed to calculate corrected differential liquid volume at normal conditions for generic products. A typical application is the measurement of fuel consumption by engines for power generators, e.g. on board ships and locomotives. The usual difficulties encountered in such applications include: pulsating flows, very low consumption readings, vibration and high ambient temperatures. These are all well catered for in the design and operation of the F127. The corrected volumetric flow in each line is calculated using the thermal expansion coefficient algorithm stored in the flowcomputer. The reference temperature can be defined as desired, e.g. 15°C, 20°C or 60°F.

Display

The display has large 17mm (0.67") and 8mm (0.31") digits which can be set to show flowrate, total and temperature. On-screen engineering units are easily configured from a comprehensive selection. The accumulated total can register up to 11 digits and is backed-up in EEPROM memory every minute.

Configuration

All configuration settings are accessed via a simple operator menu which can be pass-code protected. Each setting is clearly indicated with an alphanumeric description, therefore avoiding confusing abbreviations and baffling codes. Once familiar with one F-series product, you will be able to program all models in the series without a manual. All settings are safely stored in EEPROM memory in the event of sudden power failure.

Analog output signal

The calculated consumption (flowrate) is re-transmitted with the (0)4 - 20mA or 0 - 10V DC output signal. The output signal is updated ten times per second with a filter function being available to smoothen out the signal if desired. The output value is user defined in relation to the flowrate, e.g. 4mA equals to 15L/Hr and 20mA equals to 2000L/Hr. The output signal can be passive, active or isolated where the passive output type will loop power the F127 as well.

Signal inputs

The flowcomputer measures the uncorrected volumetric flow and temperature in both supply and return line. The F127 will accept most pulse input signals for flow. For the temperature measurement, 2 or 3 wire PT100 elements or sensors with a (0)4 - 20mA / 0 - 10V DC output signal can be used.

Communication

All process data and settings can be read and modified manually or through the Modbus communication link (RS232 / RS485). Full Modbus functionality remains available for the Intrinsically Safe version (TTL).

Hazardous area

For hazardous area applications, this model has been ATEX certified Intrinsically Safe $\text{Ex II 1 GD EEx ia IIB / IIC T4 T100}^\circ\text{C}$ with an allowed operational temperature of -30°C to $+70^\circ\text{C}$ (-22°F to $+158^\circ\text{F}$). A flame proof enclosure is also available with the rating $\text{Ex II 2 GD EEx d IIB T5}$.

Enclosures

Various types of enclosures can be selected, all ATEX approved. As standard the F127 is supplied in an ABS panel mount enclosure, which can be converted to an IP67 / NEMA 4X ABS field mount enclosure by the addition of a back case. Most popular is our rugged aluminum field mount enclosure with IP67 / NEMA 4X rating. Both European or U.S. cable gland entry threads are available.

Overview application F127

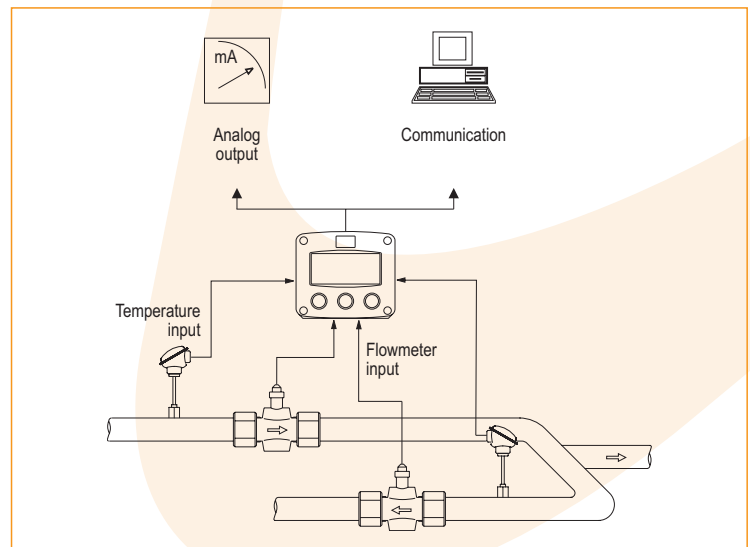

Dimensions enclosures

Enclosure HA

Aluminum field mount enclosure

IP67 / NEMA 4X
Tapped holes: European thread

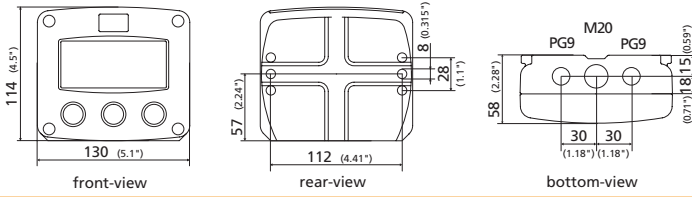

Enclosure HB

Aluminum panel mount enclosure

IP65 / NEMA 4

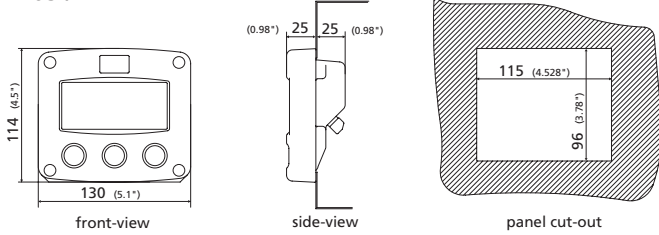

Enclosure HC (standard)

ABS panel mount enclosure

IP65 / NEMA 4

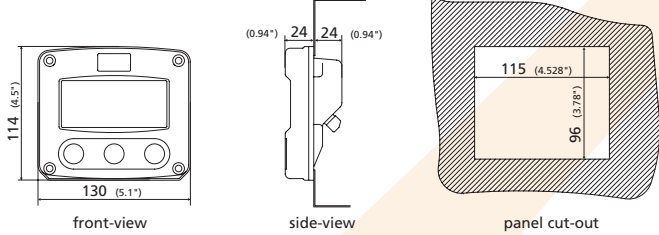

Enclosure HD

ABS wall mount enclosure

IP67 / NEMA 4X
Holes user defined

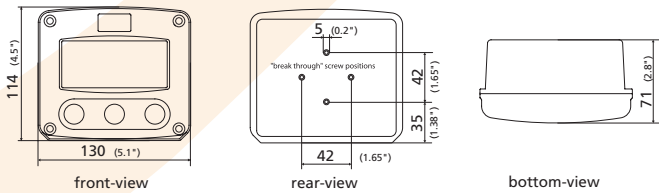

Enclosure HU

Aluminum field mount enclosure

IP67 / NEMA 4X
Tapped holes: U.S. thread

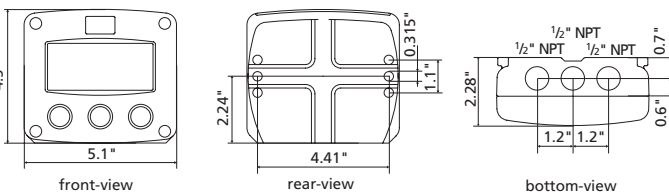

Terminal connections

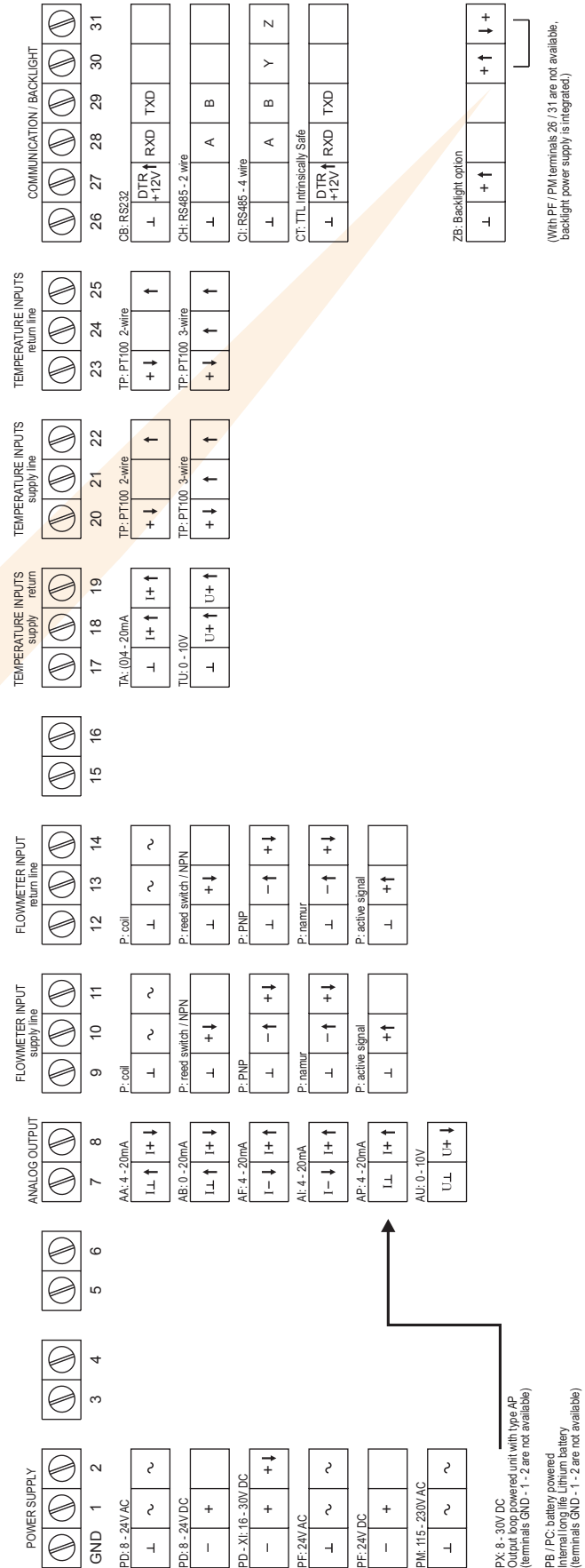

Typical wiring diagram F127-P-(AP)-CH-EL-PB-TP

Typical wiring diagram F127-P-AP-CH-EL-PX-TA

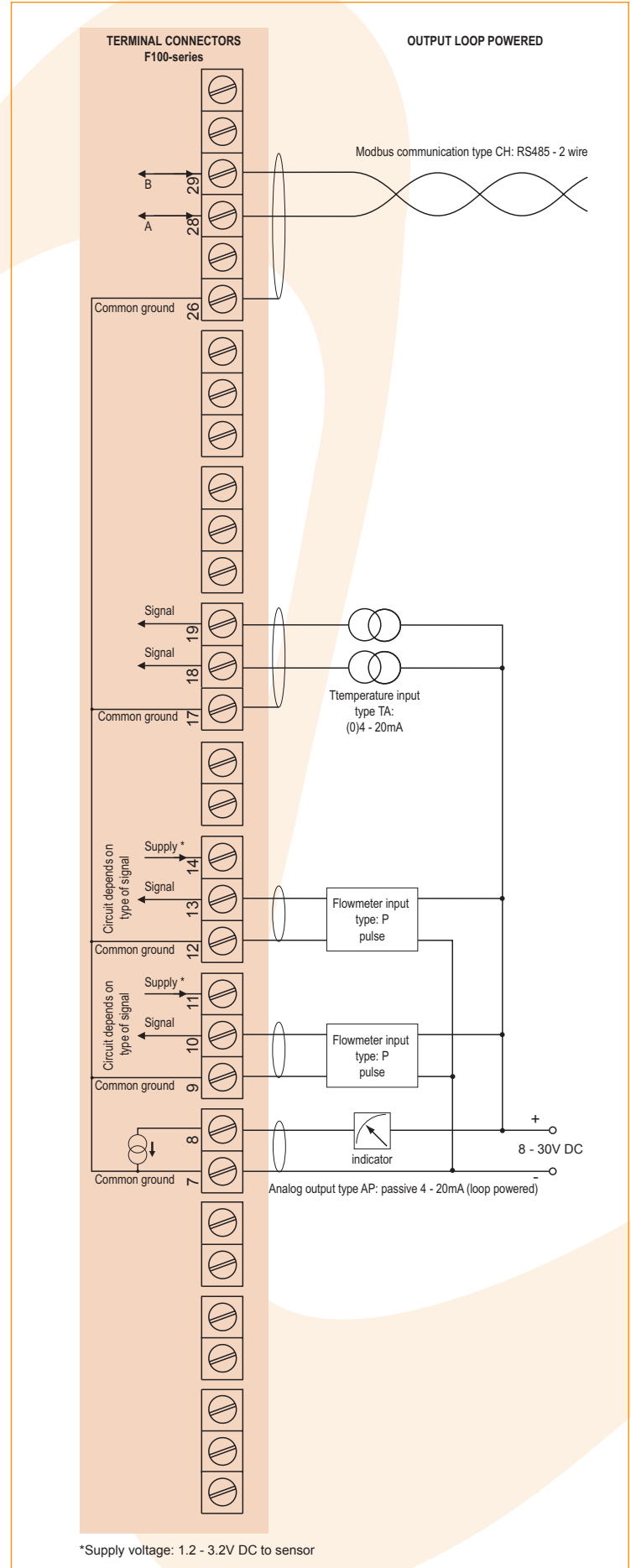
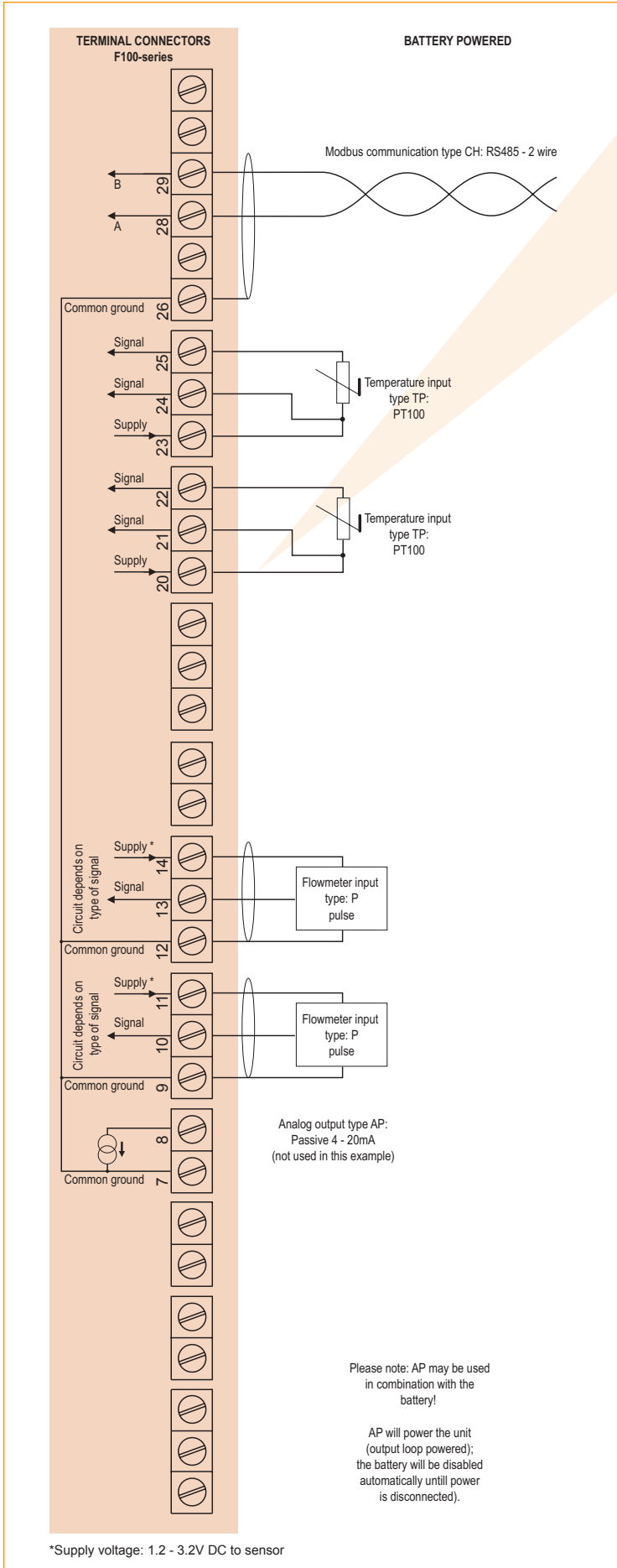

Typical wiring diagram F127-P-AI-CI-EL-PD-TA

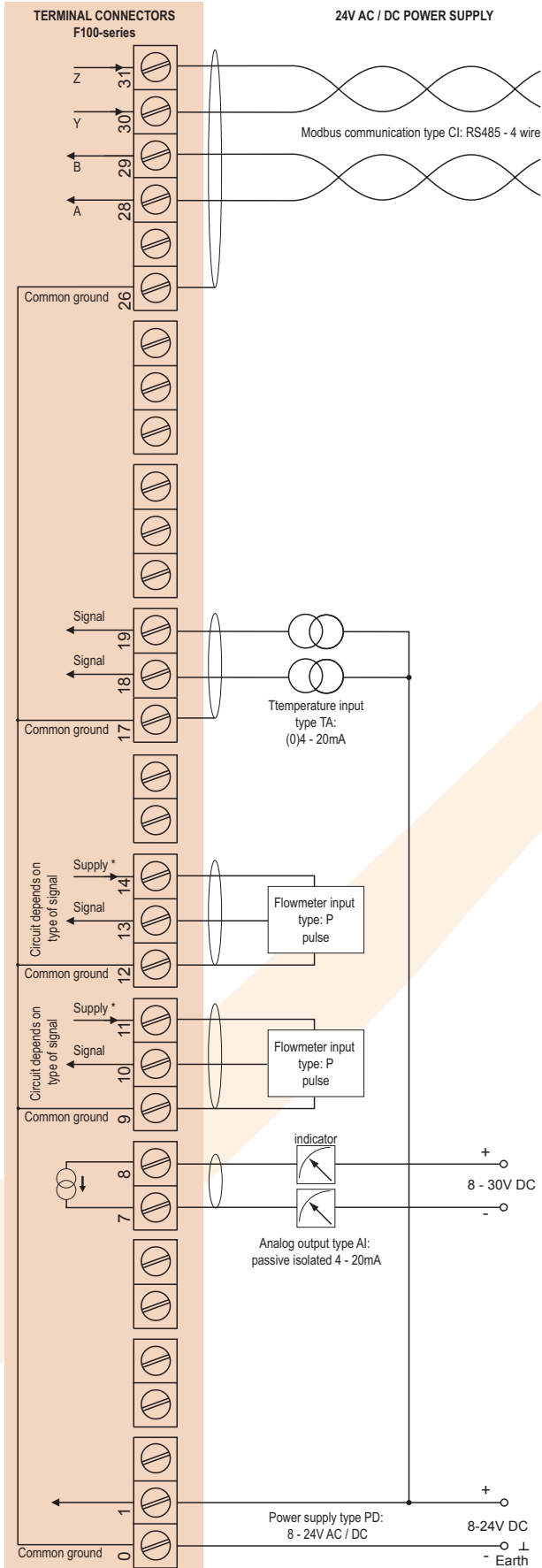

*Supply voltage: 1.2 - 3.2 - 8.2 - 12 - 24V DC to sensor

Typical wiring diagram F127-P-AA-CB-EL-PM-TP

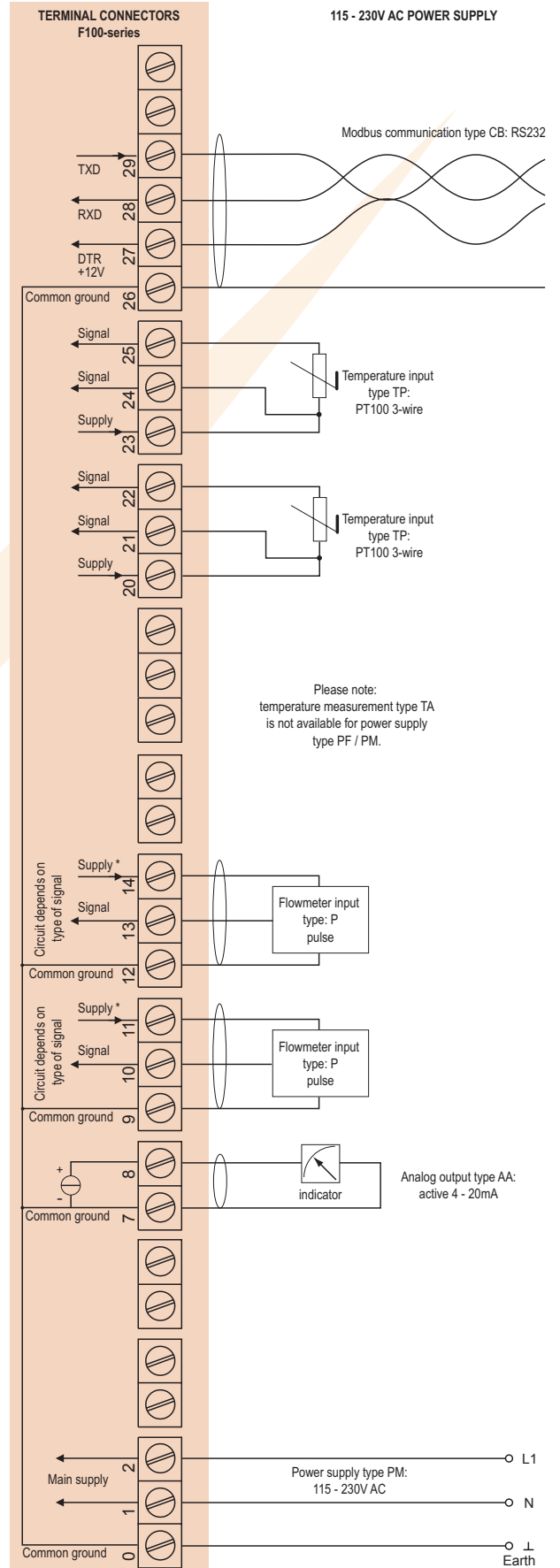

Please note:
temperature measurement type TA
is not available for power supply
type PF / PM.

*Supply voltage: 1.2 - 3.2 - 8.2 - 12 - 24V DC to sensor

Hazardous area applications

The F127-XI has been ATEX approved by KEMA for use in Intrinsically Safe applications. It is approved according to Ex II 1 GD EEx ia IIB/IIC T4 T100°C for gas and dust applications with an operational temperature range of -30°C to +70°C (-22°F to +158°F). It is allowed to connect up to six I.S. power supplies in IIB applications or one I.S. power supply in IIC applications. Full functionality of the F127 remains available, including 4 - 20mA output according to the flowrate and Modbus communication (type CT).

Power supply type PD-XI offers a 8.2V sensor supply e.g. for two Namur sensors. A flame proof enclosure with rating Ex II 2 GD EEx d IIB T5 is available as well. Please contact your supplier for further details.

Certificate of conformity KEMA 03ATEX1074 X



(1) **EC-TYPE EXAMINATION CERTIFICATE**

(2) Equipment or protective system intended for use in potentially explosive atmospheres – Directive 94/9/EC

(3) EC-Type Examination Certificate Number: KEMA 03ATEX1074 X

(4) Equipment or protective system: Indicator Model F100 Series

(5) Manufacturer: Fluidwell B.V.

(6) Address: Eisenhowerweg 1, 5466 AB Veghel, The Netherlands

(7) This equipment or protective system and any acceptable variation thereto is specified in the schedule to this certificate and the documents therein referred to.

(8) KEMA Quality B.V., notified body number 0344 in accordance with Article 9 of the Council Directive 94/9/EC of 23 March 1994, certifies that this equipment or protective system has been found to comply with the Essential Health and Safety Requirements relating to the design and construction of equipment and protective systems intended for use in potentially explosive atmospheres given in Annex II to the Directive.

The examination and test results are recorded in confidential report no. 2028528.

(9) Compliance with the Essential Health and Safety Requirements has been assured by compliance with:

EN 50014 : 1997 EN 50020 : 2002 EN 50281-1-1 : 1998 EN 50284 : 1999

(10) If the sign "X" is placed after the certificate number, it indicates that the equipment or protective system is subject to special conditions for safe use specified in the schedule to this certificate.

(11) This EC-Type Examination Certificate relates only to the design, examination and tests of the specified equipment or protective system according to the Directive 94/9/EC. Further requirements of the Directive apply to the manufacturing process and supply of this equipment or protective system. These are not covered by this certificate.

(12) The marking of the equipment or protective system shall include the following:

Ex II 1 GD EEx ia IIB/IIC T4 T100 °C

Amham, 2 July 2003
KEMA Quality B.V.

T. Pijker
Certification Manager

* This Certificate may only be reproduced in its entirety and without any change

KEMA Quality B.V.
Utrechtseweg 310, 6812 AR Amham, The Netherlands
P.O. Box 5165, 6802 ED Amham, The Netherlands
Telephone +31 26 3 56 20 08, Telefax +31 26 3 52 58 00

ACCREDITED BY THE
DUTCH ACCREDITATION
COUNCIL

Page 1/8

Configuration example IIB and IIC

F127-P-(AP)-(CT)-EL-TP-PC-XI - Battery powered unit

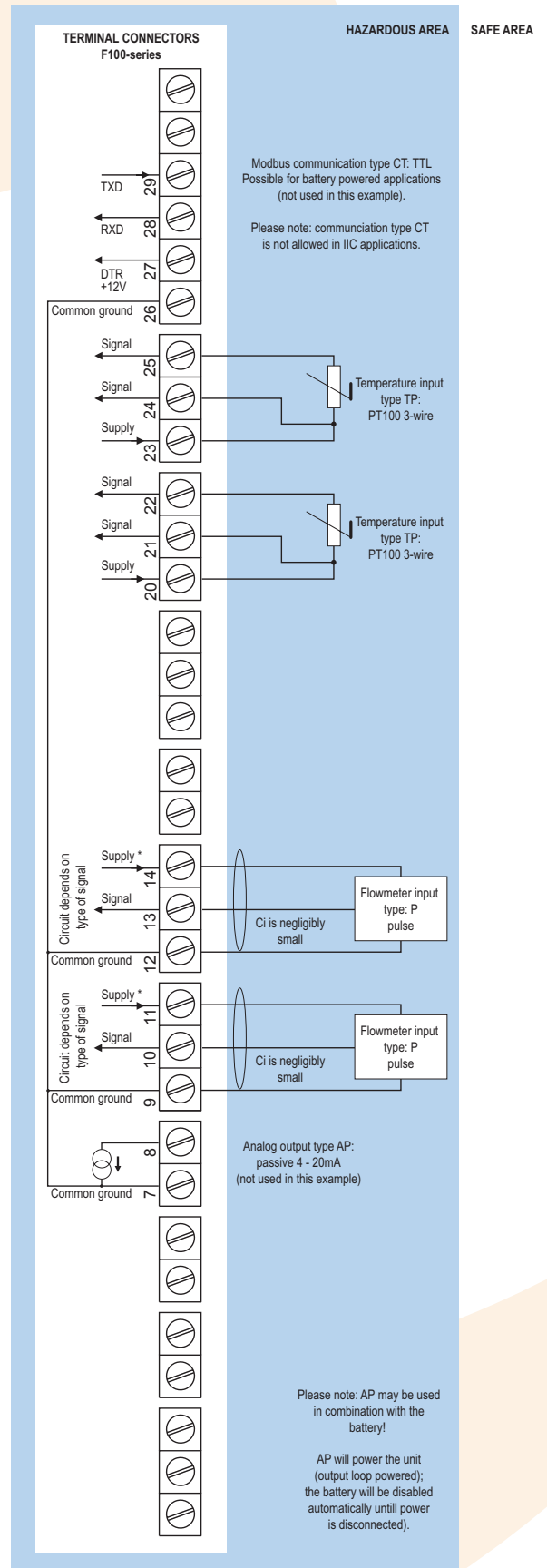

Configuration example IIB and IIC - F127-P-AP-CT-EL-PX-TP-XI - Output loop powered

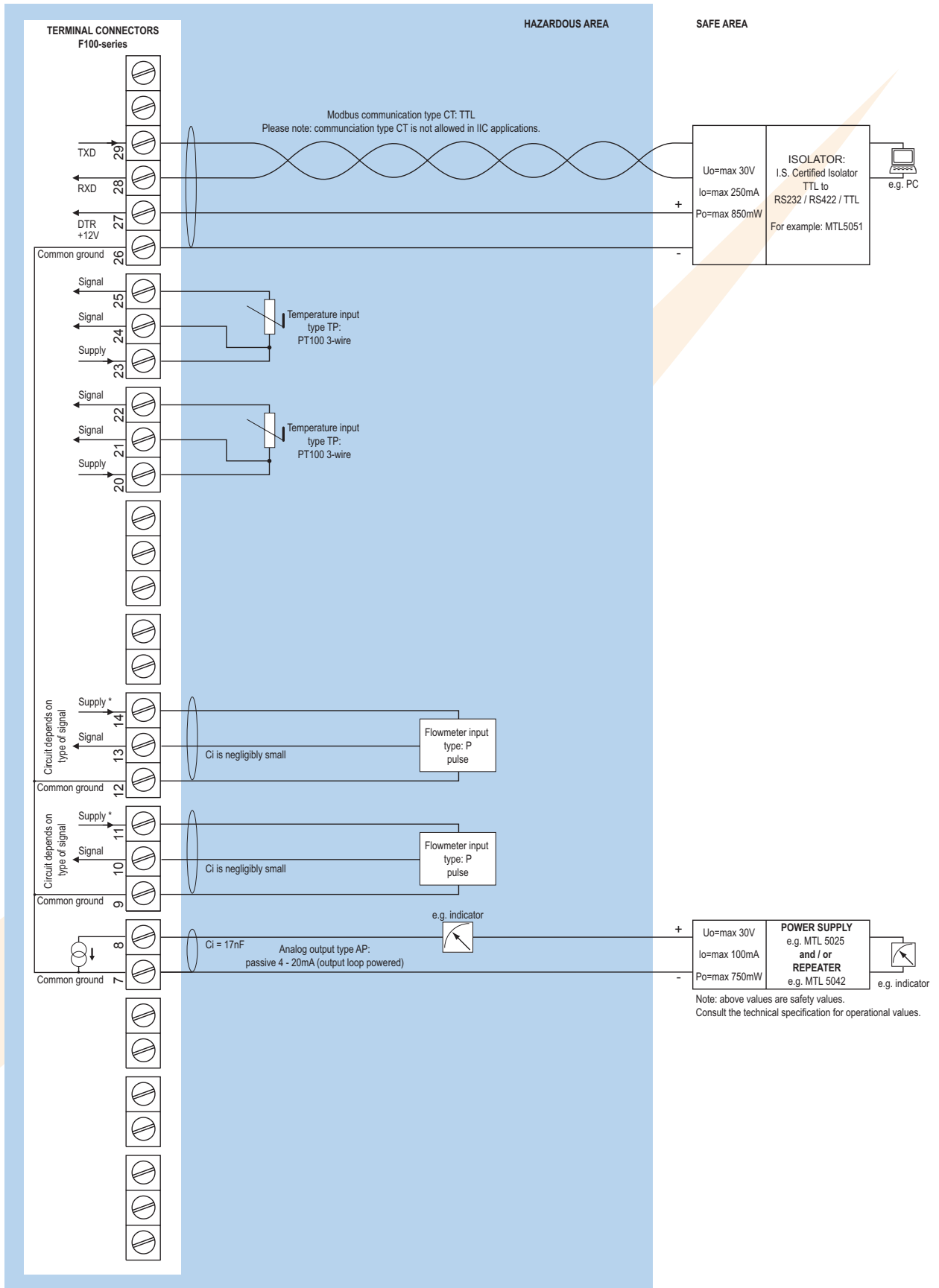

* Note sensor supply voltage: 1.2V DC for coil sensors or 3.2V DC for other pulse sensors.

Configuration example IIB and IIC - F127-P-AF-CT-EL-PD-TA-XI - Power supply 16 - 30V DC

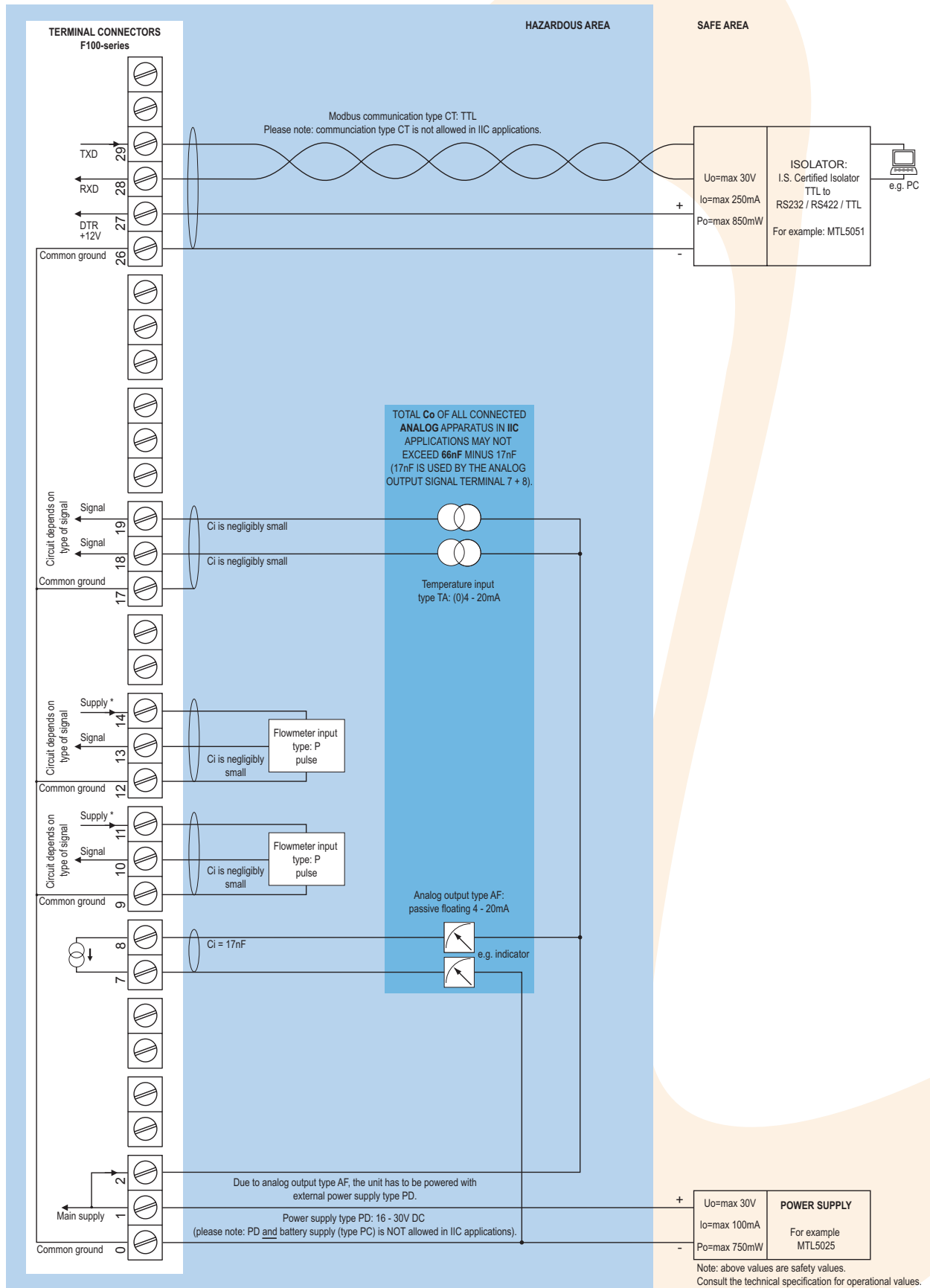

* Note power supply type PD: the supply voltage to pulse sensors is maximum 8.7V (U_o=max 8.7V I_o=max 25mA P_o=max 150mW) and to analog sensors as connected to terminal 1 (internally linked).

Configuration example IIB - F127-P-AF-CT-EL-PD-TA-XI - Power supply 16 - 30V DC

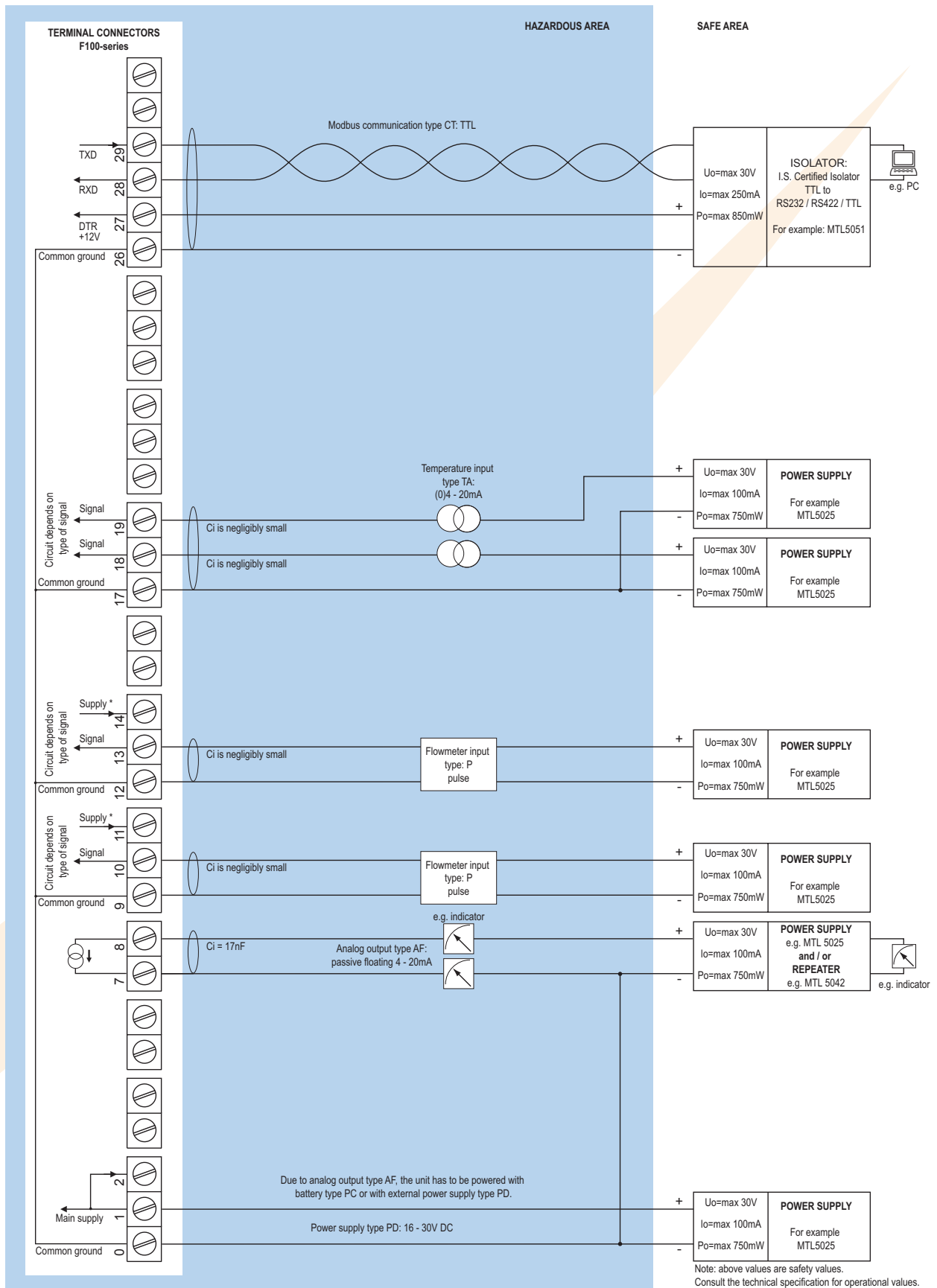

* Note power supply type PD: the supply voltage to pulse sensors is maximum 8.7V (Uo=max 8.7V Io=max 25mA Po=max 150mW) and to analog sensors as connected to terminal 1 (internally linked).

Technical specification

General

Display

Type	High intensity reflective numeric and alphanumeric LCD, UV-resistant.
Dimensions	90 x 40mm (3.5" x 1.6").
Digits	Seven 17mm (0.67") and eleven 8mm (0.31") digits. Various symbols and measuring units.
Refresh rate	User definable: 8 times/sec. - 30 secs.
Option ZB	Transflective LCD with green LED backlight. Good readings in full sunlight and darkness.
Note	Only available for safe area applications.

Casing

Window	Polycarbonate window.
Sealing	EPDM and PE.
Control keys	Three industrial micro-switch keys. UV-resistant polyester keypad.
Type HA	Die-cast aluminum field mount enclosure IP67 / NEMA 4X with 2-component UV-resistant coating.
Dimensions	130 x 114 x 58mm (5.1" x 4.5" x 2.28") - W x H x D.
Cable Entry	2 x PG9 and 1 x M20 tapped hole in the centre.
Weight	950 gr.
Type HB	Die-cast aluminum panel mount enclosure IP65 / NEMA 4 with 2-component UV-resistant coating.
Dimensions	130 x 114 x 50mm (5.1" x 4.5" x 1.97") - W x H x D.
Panel cut-out	115 x 96mm (4.53" x 3.78") LxH.
Weight	525 gr.
Type HC	ABS panel mount enclosure IP65 / NEMA 4, UV-resistant and flame retardent.
Dimensions	130 x 114 x 48mm (5.1" x 4.5" x 1.89") - W x H x D.
Panel cut-out	115 x 96mm (4.53" x 3.78") LxH.
Weight	300 gr.
Type HD	ABS wall mount enclosure IP67 / NEMA 4X, UV-resistant and flame retardent.
Dimensions	130 x 114 x 71mm (5.1" x 4.5" x 2.8") - W x H x D.
Cable Entry	None, user defined.
Weight	400 gr.
Type HU	Die-cast aluminum field mount enclosure IP67 / NEMA 4X with 2-component UV-resistant coating.
Dimensions	5.1" x 4.5" x 2.28" - W x H x D.
Cable Entry	3 x 1/2" NPT tapped hole.
Weight	950 gr.

Operating temperature

Operational	-30°C to +80°C (-22°F to +178°F).
Intrinsically Safe	-30°C to +70°C (-22°F to +158°F).

Power requirements

Type PB	Long life Lithium battery - life-time depends upon settings and configuration - up to 5 years.
Type PC	Intrinsically Safe long life lithium battery - life-time depends upon settings and configuration - up to 5 years.
Type PD	8 - 24V AC / DC \pm 10%. Power consumption max. 10 Watt. Intrinsically Safe: 16 - 30V DC; power consumption max. 0.75 Watt.
Type PF	24V AC / DC \pm 10%. Power consumption max. 15 Watt.
Type PL	Input loop powered from sensor signal 4 - 20mA (type "A") - requires types AI or AF and OT.
Type PM	115 - 230V AC \pm 10%. Power consumption max. 15 Watt.
Type PX	8 - 30V DC. Power consumption max. 0.5 Watt.
Type ZB	12 - 24V DC \pm 10% or type PD / PF / PM. Power consumption max. 1 Watt.
Note PB/PF/PM	Not available Intrinsically Safe.
Note PF/PM	The total consumption of the sensors and outputs may not exceed 400mA @ 24V.
Note	For Intrinsically Safe applications, consult the safety values in the certificate.
Note	PF and PM are only available with PT100 temperature sensors type TP.

Sensor excitation

Type PB/PC/PX	3.2V DC for pulse signals and 1.2V DC for coil pick-up.
Note	This is not a real sensor supply. Only suitable for sensors with a very low power consumption like coils (sine wave) and reed-switches.
Type PD	1.2 - 3.2 - 8.2 - 12 and 24V DC - max. 50mA @ 24V DC.
Type PD-XI	1.2 - 3.2 - 8.2V DC - max. 7mA @ 8.2V DC and mains power supply voltage (as connected to terminal 1).
Type PF / PM	1.2 - 3.2 - 8.2 - 12 and 24V DC - max. 400mA @ 24V DC.



Terminal connections

Type	Removable plug-in terminal strip. Wire max. 1.5mm ² and 2.5mm ² .
------	---

Data protection

Type	EEPROM backup of all settings. Backup of running totals every minute. Data retention at least 10 years.
Pass-code	Configuration settings can be pass-code protected.

Hazardous area

Intrinsically Safe	ATEX approval ref.:  II 1 GD EEx ia IIB/IIC T4 T100°C.
Type XI	Maximum ambient +70°C (158°F).
Explosion proof	ATEX approval ref.:  II 2 GD EEx d IIB T5.
Type XF	Dimensions of enclosure: 350 x 250 x 200mm (13.7" x 9.9" x 7.9") L x H x D.
Weight	appr. 15 Kg.

Environment

Electromagnetic compatibility	Compliant ref: EN 61326 (1997), EN 61010-1 (1993).
-------------------------------	--

Signal inputs

Flowmeter	
Type P	Coil / sine wave (minimum 20mVpp or 80mVpp - sensitivity selectable), NPN/PNP, open collector, reed-switch, Namur, active pulse signals 8, 12 and 24V DC.
Frequency	Minimum 0 Hz - maximum 7 kHz for total and flowrate. Maximum frequency depends on signal type and internal low-pass filter. E.g. reed switch with low-pass filter: max. frequency 120 Hz.
K-Factor	0.000010 - 9,999,999 with variable decimal position.
Low-pass filter	Available for all pulse signals.
Option ZF	coil sensitivity 10mVpp.

Temperature	
Accuracy	Resolution: 14 bit. Error < 0.025mA / ± 0.125% FS. Low level cut-off programmable.
Update time	Four times per second.
Type TA	(0)4 - 20mA. Analog input signal can be scaled to any desired range within 0 - 20mA.
Span	0.000010 - 9,999,999 with variable decimal position.
Offset	0.00 - 99,999.99 K.
Voltage drop	2.5V @ 20mA.
Type TP	2 or 3 wire PT100.
Range	-100°C to +200°C (-148°F to 392°F). Accuracy 0.1°C (0.18°F).
Option ZV	Range: -200°C to +800°C (-328°F to 1832°F). Accuracy 0.5°C (0.9°F).
Type TU	0 - 10 V DC. Analog input signal can be scaled to any desired range within 0 - 10V DC.
Span	0.000010 - 9,999,999 with variable decimal position.
Offset	0.00 - 99,999.99 K.
Load impedance	3kΩ.
Note 1	TA / TU are not available for PF and PM.
Note 2	For signal TA and TU: power supply to temperature sensor is required; e.g. PD.

Signal outputs

Analog output	
Function	Transmitting compensated differential flowrate.
Accuracy	10 bit. Error < 0.05%. Analog output signal can be scaled to any desired range.
Update time	Ten times per second.
Type AA	Active 4 - 20mA output (requires PD, PF or PM).
Type AB	Active 0 - 20mA output (requires PD, PF or PM).
Type AF	Passive floating 4 - 20mA output for Intrinsically Safe applications (requires PC or PD).
Type AI	Passive galvanically isolated 4 - 20mA output - also available for battery powered models (requires PB, PD, PF or PM).
Type AP	passive 4 - 20mA output - not isolated. Unit will be loop powered.
Type AU	Active 0 - 10V DC output (requires PD, PF or PM).

Communication	
Functions	Reading display information, reading / writing all configuration settings.
Protocol	Modbus RTU.
Speed	1200 - 2400 - 4800 - 9600 baud.
Addressing	Maximum 255 addresses.
Type CB	RS232
Type CH	RS485 2-wire
Type CI	RS485 4-wire
Type CT	TTL Intrinsically Safe.

Operational

Operator functions	
Displayed function	<ul style="list-style-type: none"> Compensated differential flowrate (consumption). Compensated differential total and accumulated total. Supply line - Inlet temperature and compensated flowrate. Return line - Outlet temperature and compensated flowrate. Total can be reset to zero by pressing the CLEAR-key twice.

Total	
Digits	7 digits.
Units	L, m ³ , GAL, USGAL, KG, lb, bbl, no unit.
Decimals	0 - 1 - 2 or 3.
Note	Total can be reset to zero.

Accumulated total	
Digits	11 digits.
Units / decimals	According to selection for total.
Note	Can not be reset to zero.

Flowrate	
Digits	7 digits.
Units	mL, L, m ³ , Gallons, KG, Ton, lb, bl, cf, RND, ft ³ , scf, Nm ³ , NL, igal - no units.
Decimals	0 - 1 - 2 or 3.
Time units	/sec - /min - /hr - /day.

Line temperature	
Digits	6 digits.
Units	°C, °F or K.
Decimals	1.

Flow equations	
Type EL	Corrected liquid volume.
Formula	$Q_{normal} = Q \times (1 + \alpha (T_{normal} - T))$ where α = thermal expansion coefficient.
Normal temperature	Default: 273.15 K - any temperature can be set.

Display example - 90 x 40mm (3.5" x 1.6")

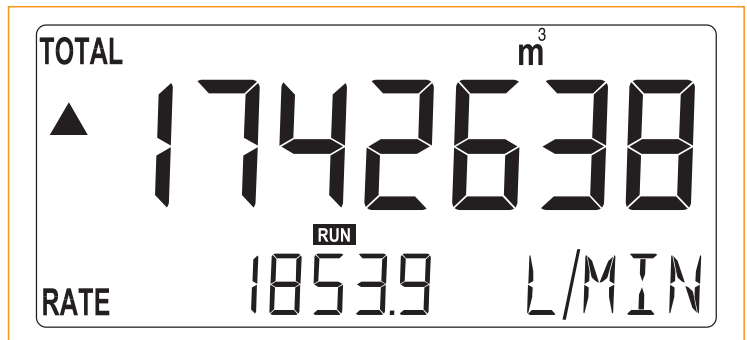

Ordering information

Example (standard configuration)

F127-P-AP-CX-EL-HC-PX-TA-XX-ZX.

Explanation standard configuration:

P: flowmeter signal: pulse; AP: passive 4 - 20mA analog output; CX: no communication; EL: equations corrected liquid volume; HC: ABS panel mount enclosure; PX: basic power supply 8 - 30V DC (requires AP); TA: (0)4 - 20mA temperature inputs; XX: safe area; ZX: no options.

Ordering information:	F127	-P	-A	-C	-EL	-H	-P	-T	-X	-Z
Flowmeter input signal										
P	☒									
Pulse: coil, npn, pnp, namur, reed-switch input.										
Analog output signal										
AA										
Active 4 - 20mA output - requires PD, PF or PM.										
AB										
Active 0 - 20mA output - requires PD, PF or PM.										
AF	☒									
I.S. floating 4 - 20mA output - requires PC or PD.										
AI										
Isolated 4 - 20mA output - requires PB, PD, PF or PM.										
AP	☒									
Passive 4 - 20mA output, loop powered unit.										
AU										
Active 0 - 10V DC output - requires PD, PF or PM.										
Communication										
CB										
Communication RS232 - Modbus RTU.										
CH										
Communication RS485 - 2-wire - Modbus RTU.										
CI										
Communication RS485 - 4-wire - Modbus RTU.										
CT	☒									
Intrinsically Safe TTL - Modbus RTU.										
CX	☒									
No communication.										
Flow equation										
EL	☒									
Corrected liquid volume.										
Enclosure										
HA	☒									
Aluminum field mount enclosure IP67 / NEMA 4X.										
HB	☒									
Aluminum panel mount enclosure IP65 / NEMA 4.										
HC	☒									
ABS panel mount enclosure IP65 / NEMA 4.										
HD	☒									
ABS wall mount enclosure IP67 / NEMA 4X.										
HU	☒									
Aluminum field mount enclosure IP67 / NEMA 4X.										
Power supply										
PB										
Lithium battery powered.										
PC	☒									
Lithium battery powered - Intrinsically Safe.										
PD	☒									
8 - 24V AC/DC + sensor supply - in combination with XI: 16 - 30V DC.										
PF										
24V AC/DC + sensor supply - only available with TP.										
PM										
115 - 230V AC + sensor supply - only available with TP.										
PX	☒									
Basic power supply 8 - 30V DC (no real sensor supply). Unit requires external loop AP.										
Temperature input signal										
TA	☒									
(0)4 - 20mA input.										
TP	☒									
PT100 input.										
TU	☒									
0 - 10V DC input.										
Hazardous area										
XI	☒									
Intrinsically Safe.										
XF	☒									
EExd enclosure - 3 keys.										
XX	☒									
Safe area only.										
Options										
ZB										
Backlight.										
ZF	☒									
Coil input 10mVpp.										
ZV	☒									
PRTD-range -200°C / +800°C.										
ZX	☒									
No options.										

The bold marked text contains the standard configuration.

☒ Available Intrinsically Safe.

Specifications are subject to change without notice.