

Nokeval

No 050101

**User's Manual
Models 301 & 302
and 305 & 306**



Contents

Autopowered LED-displays	3
General description	3
Disabling front panel keys	4
Front panel buttons and indicators	5
Configuration mode	5
Resetting configuration parameters	5
Alarm level setting	5
Alarm functions	5
Disable alarms	5
Manual reset	5
Configuration	6
Enter configuration mode	6
Access code for configuration	6
Description	7
Input terminals	7
Alarm connections, only with model 302	7
Measuring mode	7
Configuration mode	7
Alarms off	7

Manufacturer:

Nokeval Oy	Tel.	+358 (0)3 342 4800
Yrittäjätatu 12	Fax.	+358 (0)3 342 2066
37100 NOKIA	email	mail@nokeval.com
FINLAND	http://	www.nokeval.com

Autopowered LED-displays

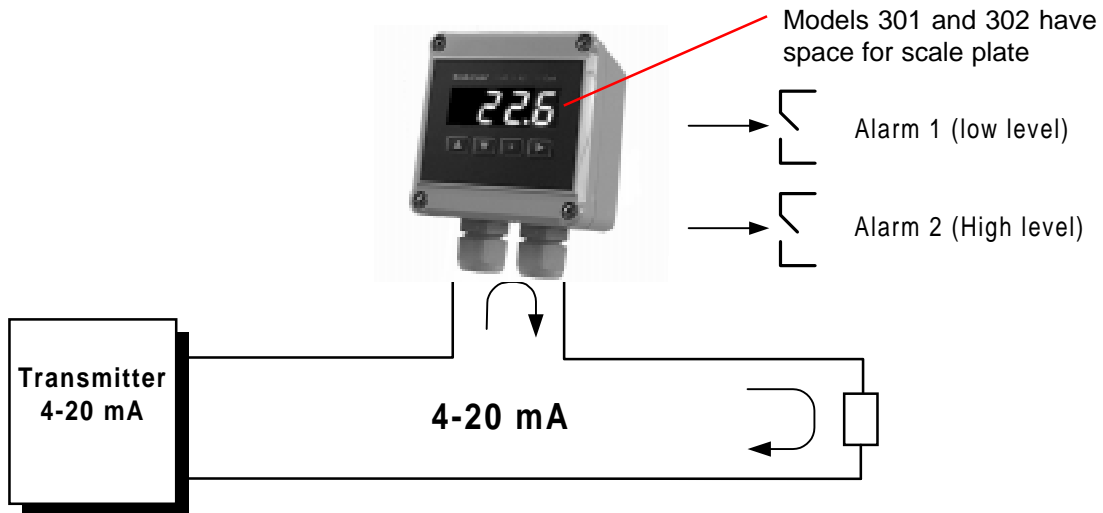

- For process input 4-20 mA
- Without external power supply
- Loop resistance 240 ohm only
- 4-digit processor based display
- Scaling on front panel
- 2 settable alarms (option)
- Passwords for alarms and configuration
- Field enclosure rating IP 65

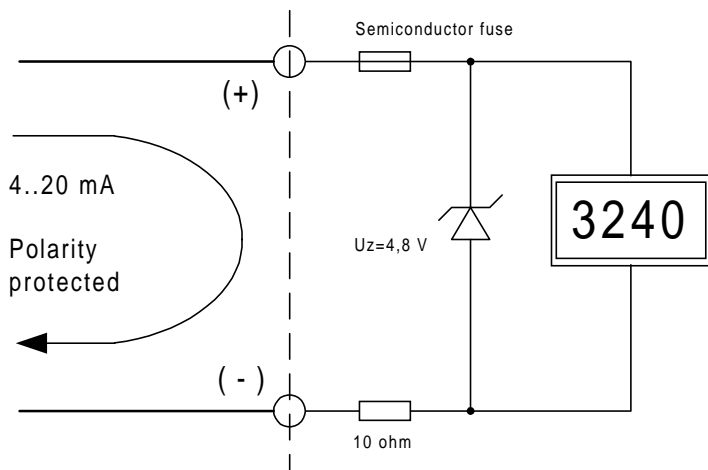

General description

Autopowered bright red LED-displays need no external power supply. Current signal 4-20 mA provides the necessary energy. Therefore, it is possible to install the meter in places having no auxiliary power available. You can now replace the autopowered LCD-displays, having very poor visibility, by bright red LED-displays. There are four models according to optional alarms and plastic case (ABS) IP65 size: 100 x 100 mm basic model 301 without alarms and model 302 with two alarm contacts. Correspondingly models 305 and

306 are in 82 x 80 x 57 mm case. Both size versions has same functions.

Display scaling and configuration by front panel buttons. Unit has digital filter for stabilizing the 4-digit display. In models 302 and 306 You may configure two optional alarms, high and low. More versatile alarm settings and alternative alarm modes offers our powered models 2011 and 2021. Password is settable for entering configuration and alarm stages.

Technical specifications:

Input	4..20 mA
Display scaling	-999....+9999
Accuracy	0.05% of span
Input voltage drop 301	continuous 4,8 V = 4-20 mA (comparable 240 Ω, non resistive)
302	continuous 7,3 V = 4-20 mA (comparable 340 Ω, non resistive) with alarms
Alarm relays (option)	2 solid state relays (SSR), max. 250 VAC, 150 mA
Alarm reset	automatic or manual (hold) via front panel key
Alarm mode	High and low level
Hysteresis	Selectable 0..100 %
Display	4-digit red LED, 14.5 mm, adjustable brightness
Push buttons	Switches under front panel surface
Case protection	IP65
Case material and color	ABS-plastic, grey
Case dimensions:	301/302 100 x 100 x 57 mm
	305/306 82 x 80 x 57 mm
Ambient temperature	0...+60 °C
Terminals	Detachable 2,5 mm ² (models 305 and 306 1,5 mm ²)
Weight	200 g

Order codes:

Model 301-4/20 mA	4-digit 4-20 mA loop powered indicator
Model 302-4/20 mA	With optional 2 alarms
Model 305-4/20 mA	Smaller case 82 x 80 x 57mm
Model 306-4/20 mA	Smaller case with alarms

Connections:

Disabling front panel keys

Use of front panel keys can be enabled/disabled with short cut jumper. When short cut jumper is installed keys can be used to configure and set alarm levels.

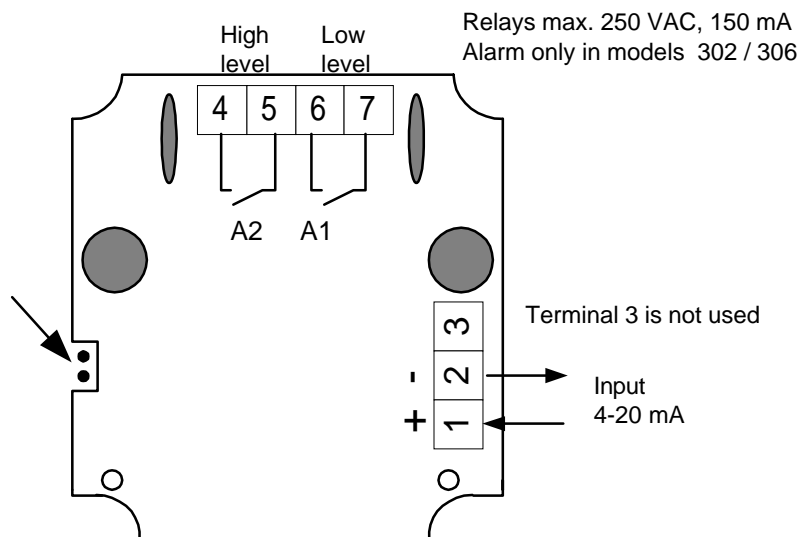

Case dimensions (mm):

Inlets 2 x 11 mm PG
Case protection IP65
Case material ABS.

Models 305 and 306 dimensions are in brackets.
This small size enclosure has only one PG11 inlet.

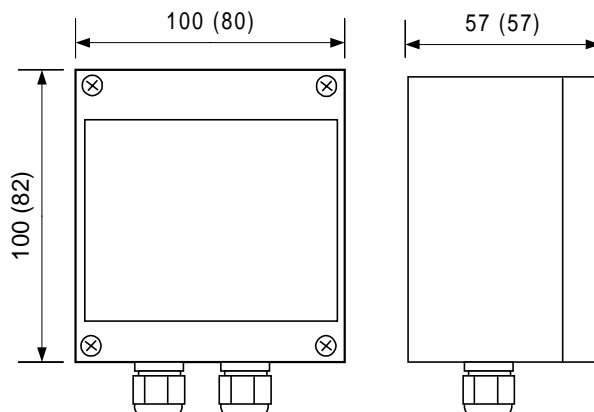

Front panel buttons and indicators

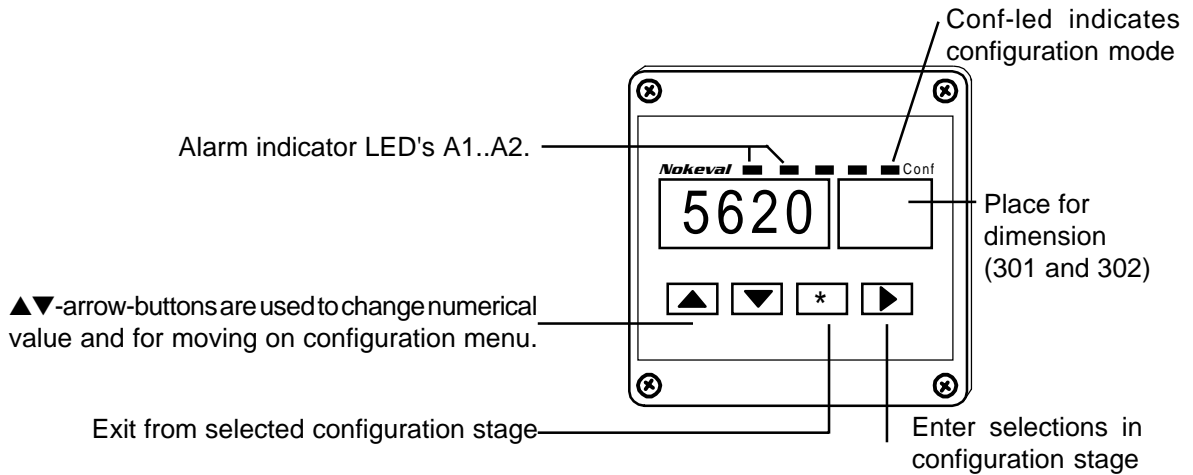

Configuration mode

Configuration can be started by pressing and holding ★- and ▲-keys simultaneously for 2 seconds. Configuration stage is for selecting input, display scaling and alarm function. Specified instructions on pages 6-7 section Configuration.

Resetting configuration parameters

Some times it is necessary to return indicator parameters to factory defaults, e.g. if secret access code is missed. Resetting can be done by pressing and holding ★- and ►-keys simultaneously for 2 seconds when connecting input signal 4..20 mA. Procedure will reset all settings to factory defaults.

Alarm functions

Alarms can be viewed in configuration mode. Special instructions on pages 6-7, section configuration.

Disable alarms

Negative hysteresis value disables alarm function.

Manual reset

Auto reset is a standard function. Manual reset with front panel ▼-key can be selected by choosing wider hysteresis than full span (Hi -Lo). For example: Input scaling is 0..100,0 i.e. full span is 100. Select hysteresis larger than 100 (9999) and You will have manual reset.

Alarm level setting

Alarm levels are selected with ▲▼-buttons one number at a time. Changing begins from the most significant digit on the left, decimal point is selected first. Next digit to right is selected with ►-button. Accept and exit with ★ -button.

Value selection

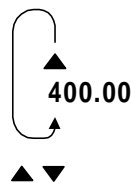

Numbers
0...9

Selecting next digit

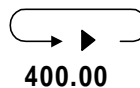

Decimal point selection
with ▲▼ -keys before
number selection

Configuration

Configuration can be started by pressing and holding **★**- and **▲**-keys simultaneously for 2 seconds. Arrow keys **▲▼** moves up and down in main menu. Desired function is selected with **▶**-key. Save mode can be selected directly by pushing **★**-key in main menu.

Alarm values and hysteresis are selected in configuration mode.

Changes can be restored by selecting text UnDO into display and pressing **▶**-key. **Note!** Detailed configuration stage description on next page.

Enter into configuration mode

Configuration can be started by pressing and holding **★**- and **▲**-keys simultaneously for 2 seconds. Arrow keys **▲▼** move up and down in main menu.

Access code for configuration

Configuration mode can be secured with pass word. If function is selected unit asks **CODE**. Enter required key combination as shown on page 7 section **CFCo**.

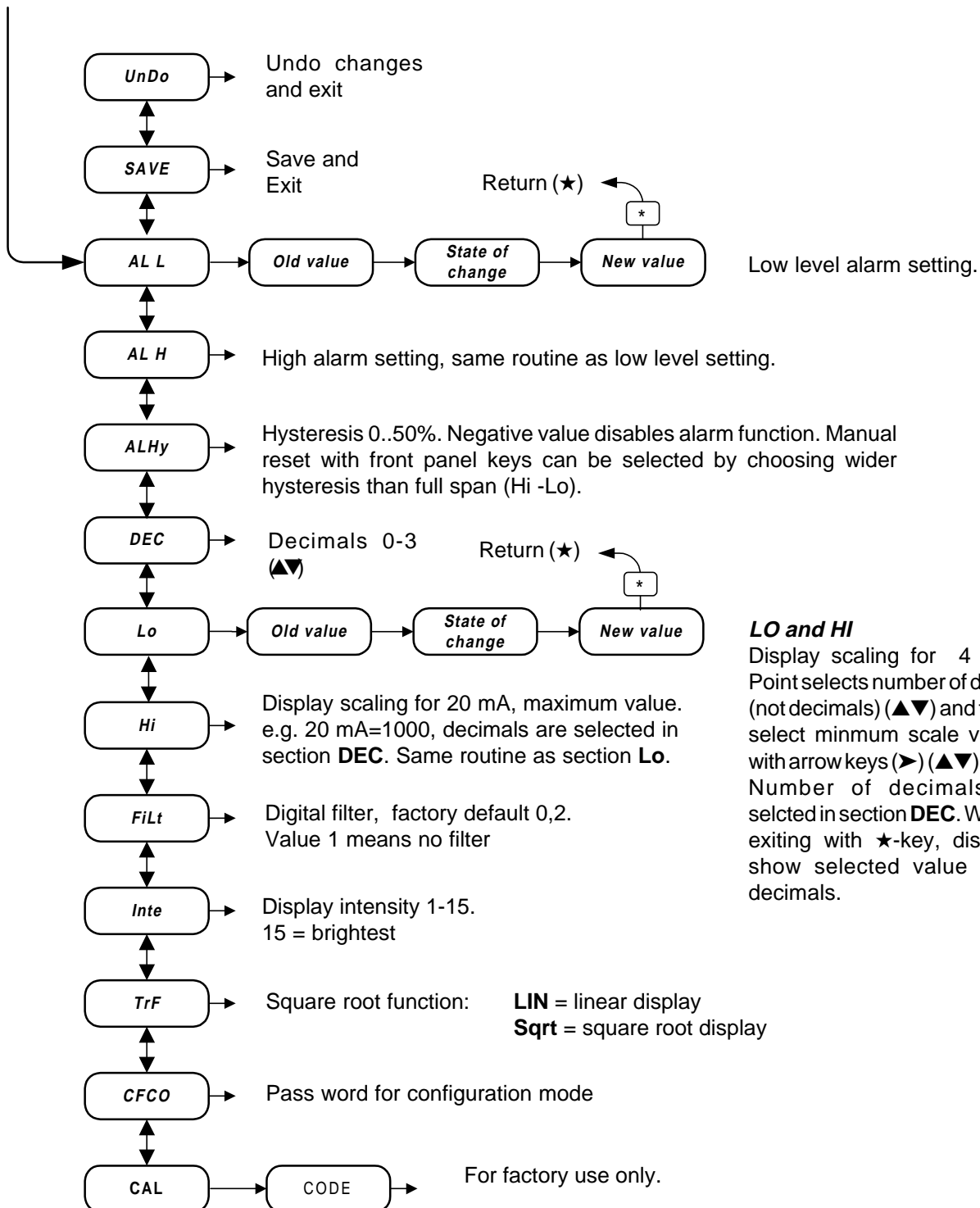

LO and HI

Display scaling for 4 mA. Point selects number of digits (not decimals) (▲▼) and then select minimum scale value with arrow keys (▶) (▲▼). Number of decimals is selected in section **DEC**. When exiting with **★**-key, display show selected value with decimals.

Description

Input terminals

- 1 (+) signal loop (4...20mA)
- 2 (-) signal loop
- 3 Not used, can be used as a spare terminal

Voltage drop in 4..20 mA input loop is max 4.8 V. This corresponds 240 ohm loop resistance. When alarms are used (optional) voltage drop is max 7,3 V. Input is secured for reversed polarity and over current tolerance is 100 mA.

Alarm connections, only models 302 and 306

- 6, 7** Low level alarm, display is lower than alarm level
4, 5 High level alarm, display is higher than alarm level

Solid state relays, SSR: max. 250 V \pm DC/AC, 150 mA, 12 ohm. Isolation between input loop 4 kV.

Alarms can be taken into use by removing jumper inside the case. Voltage drop will increase to 7,3 V.

Measuring mode

This is normal operating mode. Scaled input signal is in display. LED indicator functions are:

- A1 = Low level alarm
- A2 = High level alarm
- Conf = Unit in configuration or calibration mode

Measuring mode can be changed to Configuration mode by pressing simultaneously **▲★**-keys. If access code is used it must be entered when display shows **Code**.

Configuration mode

Undo, Save ►

Exit from configuration mode. **SAVE** saves new configuration and **Undo** exits without saving.

AL L, AL H ►

Alarm levels (L=low, H=high). Both alarms cannot be energized at the same time. Therefore low level cannot have higher value than high alarm and vice versa.

If input signal is under 3 mA relays will be de-energized. (Normal open 'NO' relays need energy to be closed).

ALHy ►

Alarm hysteresis is number of digits below or above selected alarm level (both sides have same value). Normally alarm relays are energized when display value goes to alarm level and de-energized when it goes over hysteresis value.

Alarms can also have manual reset when hysteresis

value is set larger than measuring range (full span). Manual reset is done with **▼**-key from front panel.

An example of Manual reset / hold function:

High level alarm is 100 °C and low level -5 °C. When input is over 100 °C, LED A2 lits (relay A2 energized) and it don't go off even if the input goes below 100 °C. It must be resetted manually with front panel key **▼**. Alarm will be resetted also if input goes below selected low level (-5°C). That is because both relays cannot be energized at the same time. If You do not want to use this possibility given by the other alarm, select it's value outside that the scaled range (not in use).

Alarms off

Negative hysteresis value disables alarm function.

Dec ►

Decimal selection 0..3, i.e. 0.9, 0.99 or 0.999

Lo, Hi ►

Lo and **Hi** scales display to input signal 4..20 mA. **Lo** value is selected for input 4 mA and correspondingly **Hi** value is for 20 mA input.
e.g. 4..20 mA = display **Lo** -100.. **Hi** +200

Filt ►

Display Filter. This function stabilizes display value when wide measuring range is used.

Filter value can be set between 1 (min) ..0.010 (max).

1.000 = no filter

0.200 = normal filter

e.g. 0.2 =(1/5) one new measurement and 4 old values or

0.1 = (1/10) one new + 9 old values (slower)

Alarms are controlled with the filtered value (filter affects to alarms reaction time).

Inte ►

Display intensity (brightness). You can change the intensity with **▲▼**-buttons. Hold **▼**-key to decrease intensity and vice versa.

In measuring mode intensity decreases automatically when input is under 6 mA.

TrF ►

Transfer function selection.

Lin = normal function

Sqrt = square root function

CFCo ►

Access code for configuration mode. Access code is formed with **▲▼★►**-keys. Code is formed with six pushes of front panel buttons. Not in use when code is set to **(★★★★★)** (factory default).

If configuration access code is forgotten, all the settings can be returned to factory defaults (not calibration) by holding down buttons **★** and **►** while connecting input signal 4..20 mA.

Calibration

When calibrating, accurate 4 and 20 mA signals are needed. The device is factory supplied calibrated, and it is scaled to display 0-100.0 unless ordered differently.

CAL >

If the device displays incorrect readings (more than 0.05% of range), it should be recalibrated. Before doing that, ensure that the input signal is correct (using a separate mA meter) and that the scaling (Lo, Hi) is appropriate.

Enter configuration menu, select CAL and press ► key. Enter calibration password 112213, ▲▲▼▼▲★. "4_20" is displayed.

Feed a precise 4.000 mA signal to the device and press ▼ key. Wait until the display reappears. Then feed 20.000 mA and press ▲ key. Calibration values are stored immediately and cannot be undone.

Finally exit to the configuration menu with ★ key.

Manufacturer:

Nokeval Oy
Yrittäjäkatu 12
37100 NOKIA
FINLAND

Tel. +358 (0)3 342 4800
Fax. +358 (0)3 342 2066
email mail@nokeval.com
http:// www.nokeval.com