

To prevent accidents arising from the misuse of this controller, please ensure the operator using it receives this manual.

⚠ Caution

- This instrument should be used according to the specifications described in the manual. If it is not used according to the specifications, it may malfunction or cause fire.
- Be sure to follow the warnings, cautions and notices. If not, it could cause serious injury or malfunction.
- Specifications of the JCS-33A and the contents of this instruction manual are subject to change without notice.
- This instrument is designed to be installed in a control panel. If not, measures must be taken to ensure that the operator cannot touch power terminals or other high voltage sections.
- Be sure to turn the power supplied to the instrument OFF before cleaning this instrument.
- Use a soft and dry cloth when cleaning the instrument.
(If paint thinner is used, it might deform or tarnish the unit.)
- As the display section is vulnerable, do not strike or scratch it with a hard object.
- Any unauthorized transfer or copying of this document, in part or in whole, is prohibited.
- Shinko Technos CO., LTD. is not liable for any damages or secondary damages incurred as a result of using this product, including any indirect damages.

1. Name

1.1 Model name

JCS-3 3 □-□/□ □, □□□		Series name: JCS-33A (W48 x H48 x D96.5mm)	
Control action	3	PID	
A1	A	Alarm action is selectable by key operation. *1	
OUT1	R	Relay contact: 1a	
	S	Non-contact voltage (for SSR drive): 12 ⁺² ₀ V DC	
	A	DC current: 4 to 20mA DC	
Input	M	Multi-range *2	
Supply voltage	1	24V AC/DC *3	
Option	A2	Alarm 2 (A2) *1	
	W (5A)	Heater burnout alarm	CT rated current: 5A
	W (10A)		CT rated current: 10A
	W (20A)		CT rated current: 20A
	W (50A)		CT rated current: 50A
	DT	OUT2 (Heating/Cooling control output)	Non-contact relay
	C5	Serial communication (RS-485)	
	SM	SV1/SV2 external selection	
	LA	Loop break alarm	
	BK	Color Black	
TC	Terminal cover		

*1: Alarm actions (9 types and No alarm action) and Energized/Deenergized can be selected by key operation.

*2: Thermocouple, RTD, DC current, and DC voltage can be selected by key operation.

*3: 100 to 240V AC is standard specification for the supply voltage. However, when ordering 24V AC/DC, enter "1" after the input code.

1.2 How to indicate the model nameplate

Model nameplates are put on the case and on the inner assembly.

For Heater burnout alarm output, CT rated current is written in the bracket.

(1): Model name (2): Option, supply voltage ("1" is entered only for 24V AC/DC)
(3): Instrument No. (Only on inner assembly)

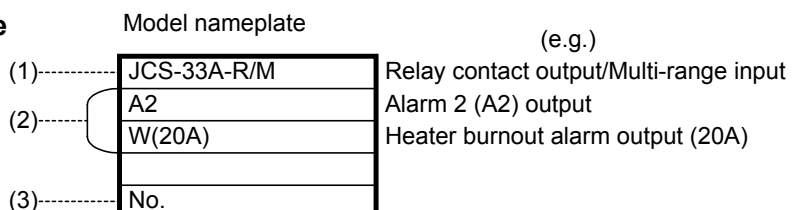

2. Name and functions of the sections

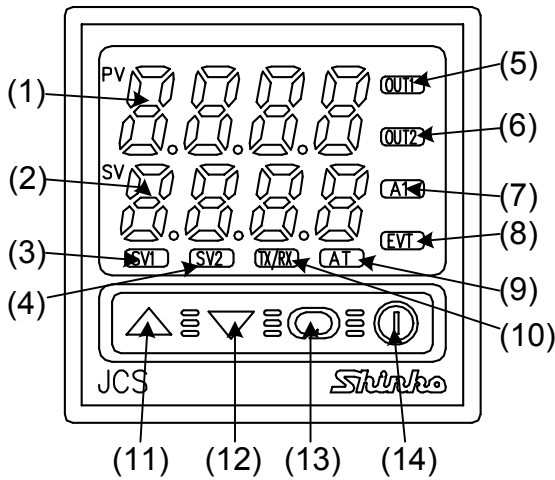

(Fig. 2-1)

- (1) **PV display**: Indicates the input value with a red LED.
- (2) **SV display**: Indicates the setting value with a green LED.
- (3) **SV1 indicator**: A green LED lights up when SV1 is indicated on the SV display.
- (4) **SV2 indicator**: A yellow LED lights up when SV2 is indicated on the SV display.
- (5) **OUT1 indicator**: When OUT1 or heating output is ON, a green LED lights up. (For A/□ type, it blinks corresponding to the manipulated variable in a 0.25 second cycle)
- (6) **OUT2 indicator**: When OUT2 (option DT) is ON, a yellow LED lights up.
- (7) **A1 indicator**: When A1 output is ON, a red LED lights up.
- (8) **EVT indicator**: When Event output (option: A2, LA or W) is ON, a red LED lights up.
- (9) **AT indicator**: When auto-tuning or auto-reset is being performed, a yellow LED blinks.
- (10) **TX/RX indicator**: A yellow LED blinks during serial communication output (transmitting).
- (11) **Increase key**: Increases the numeric value.
- (12) **Decrease key**: Decreases the numeric value.
- (13) **Mode key**: Selects the setting mode or registers the setting value.
(By pressing the Mode key, the setting value or selected value can be registered)
- (14) **OUT/OFF key**: The control output ON/OFF function or Auto/Manual control function can be switched. (To cancel the control output ON/OFF function, press the OUT/OFF key again for approx. 1 second.)



Notice

When setting the specifications and functions of this controller, connect the terminals 1 and 2 for power source first, then set them referring to “5. Setup” before performing “3. Mounting to control panel” and “4. Wiring connection”.

3. Mounting to control panel

3.1 Site selection

This instrument is intended to be used under the following environmental conditions (IEC61010-1): Overvoltage category II, Pollution degree 2

Mount the controller in a place with:

- A minimum of dust, and an absence of corrosive gases
- No flammable, explosive gasses
- Few mechanical vibrations or shocks
- No exposure to direct sunlight, an ambient temperature of 0 to 50°C (32 to 122°F) that does not change rapidly
- An ambient non-condensing humidity of 35 to 85%RH
- No large capacity electromagnetic switches or cables through which large current is flowing
- No water, oil or chemicals or where the vapors of these substances can come into direct contact with the controller

3.2 External dimension

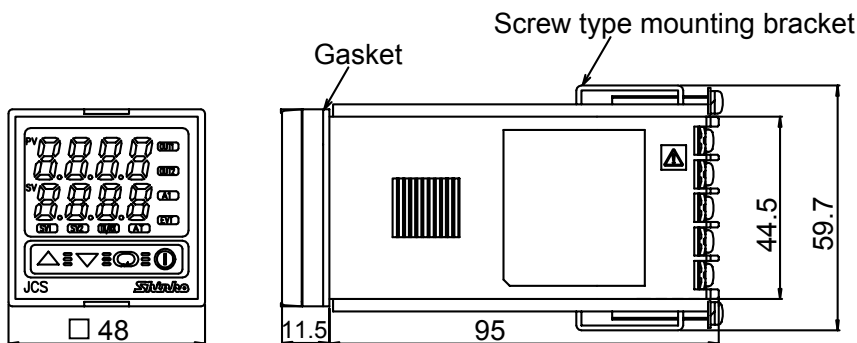

(Fig. 3.2-1)

3.3 Panel cutout

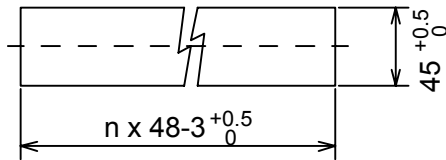
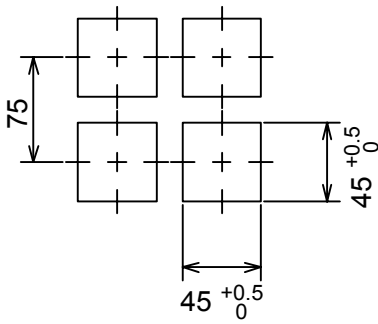

Lateral close mounting
n: Number of units mounted

⚠ Caution: If lateral close mounting is used for the controller, IP66 specification will not be fulfilled.

(Fig. 3.3-1)

3.4 CT (Current transformer) external dimension

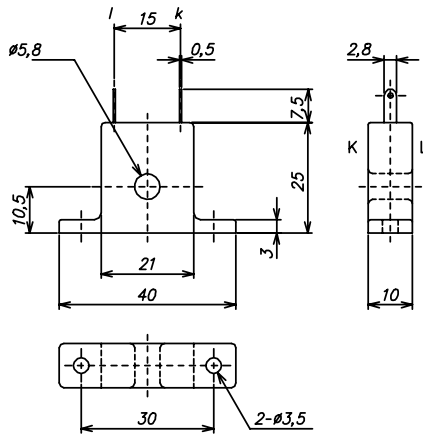

CTL-6S (for 5A, 10A, 20A)

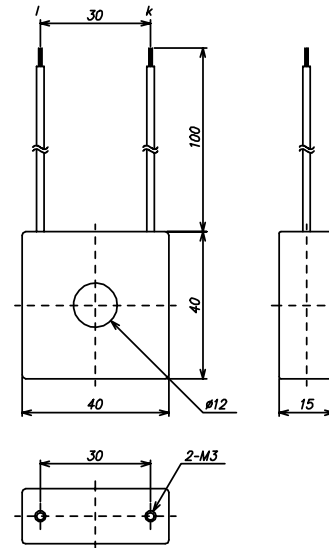

CTL-12-S36-10L1 (for 50A)

(Fig. 3.4-1)

3.5 Mounting

Mount the controller vertically to fulfill the Dust-proof/Drip-proof specification (IP66).

Mountable panel thickness: Within 1 to 15mm

Insert the controller from the front side of the panel.

Attach the mounting brackets by the holes at the top and bottom of the case and secure the controller in place with the screws.

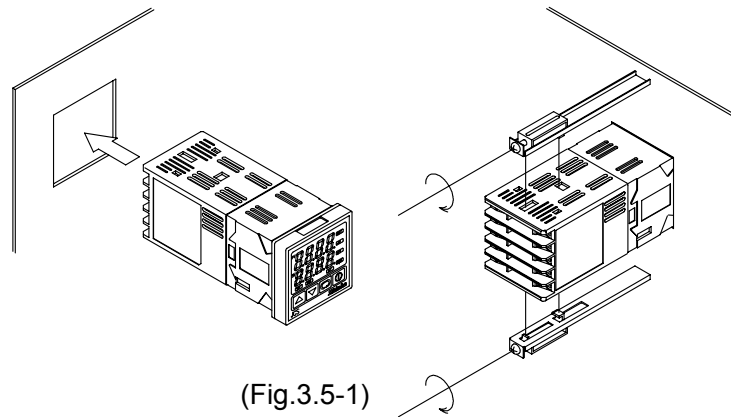

(Fig.3.5-1)



Warning

As the case is made of resin, do not use excessive force while screwing in the mounting bracket, or the case or screw type mounting bracket could be damaged. The torque is approximately 0.12N•m.

4. Wiring connection



Warning

Turn the power supply to the instrument off before wiring or checking it.
Working or touching the terminal with the power switched on may result in Electric Shock causing severe injury or death.

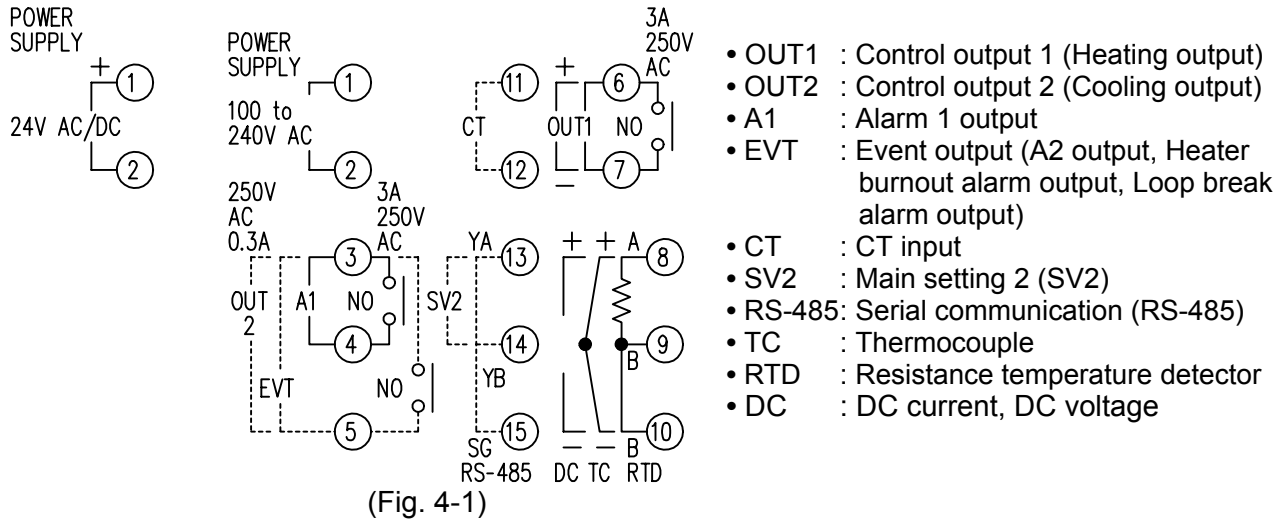

Notice

- The terminal block of the JCS-33A is designed to be wired from the left side. The lead wire must be inserted from the left side of the terminal, and fastened by the terminal screw.
- Dotted lines show options.
- Use a thermocouple and compensating lead wire according to the sensor input specification of this controller.
- Use the 3-wire RTD which corresponds to the input specification of this controller.
- This controller does not have built-in power switch, circuit breaker or fuse. Therefore, it is necessary to install them in the circuit near the external controller.
(Recommended fuse: Time-lag fuse, rated voltage 250V AC, rated current 2A)
- **When using a 24V AC/DC for the power source, do not confuse the polarity when it is DC.**
- When using a relay contact output type, externally use a relay according to the capacity of the load to protect the built-in relay contact.
- When wiring, keep input wires (thermocouple, RTD, etc.) away from AC sources or load wires to avoid external interference.
- Do not apply a commercial power source to the sensor connected to the input terminal nor allow the power source to come into contact with the sensor.

Lead wire solderless terminal

Use a solderless terminal with isolation sleeve that fits in the M3 screw as shown below. The torque is approximately 0.6N•m to 1.0N•m.

Solderless terminal	Manufacturer	Model name	Tightening torque
Y type	Nichifu Terminal Industries CO.,LTD.	1.25Y-3	0.6N•m Max. 1.0N•m
	Japan Solderless Terminal MFG CO.,LTD.	VD1.25-B3A	
Round type	Nichifu Terminal Industries CO.,LTD.	1.25-3	
	Japan Solderless Terminal MFG CO.,LTD.	V1.25-3	

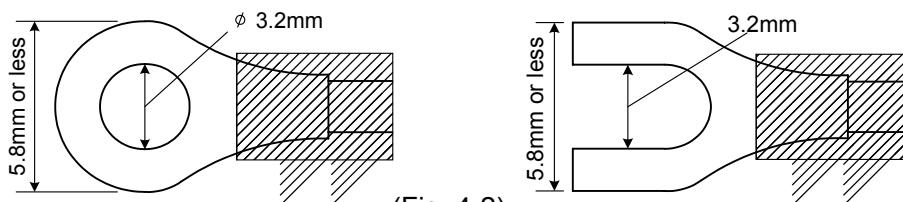

Option: Heater burnout alarm

- (1) **This alarm is not available for detecting heater current under phase control.**
- (2) Use the current transformer (CT) provided, and pass one lead wire of the heater circuit into the hole of the CT.
- (3) When wiring, keep the CT wire away from AC sources or load wires to avoid the external interference.

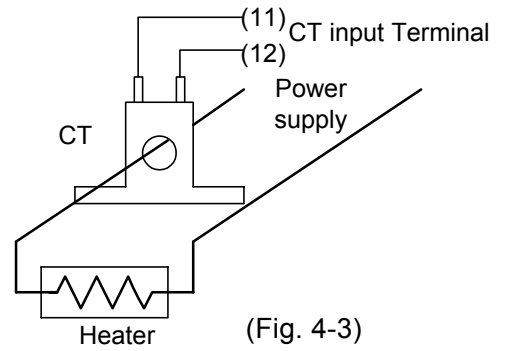

(Fig. 4-3)

5. Setup

Wire the power terminals only. After the power is turned on, the sensor input characters and temperature unit are indicated on the PV display and the input range high limit value is indicated on the SV display for approximately 3 seconds. (Table 5-1)

(If any other value is set during the scaling high limit setting, the set value is indicated on the SV display) During this time, all outputs and the LED indicators are in OFF status.

Control will then start and the input value will be indicated on the PV display and main setting value (SV) will be indicated on the SV display. (While control output OFF function is working, OFF is indicated on the PV display.)

(Table 5-1)

Sensor input	°C		°F	
	PV display	SV display	PV display	SV display
K	K	1370	F	2500
J	J	4000	F	7500
R	R	1000	F	1800
S	S	1760	F	3200
B	B	1760	F	3200
E	E	1820	F	3300
T	T	800	F	1500
N	N	4000	F	7500
PL-II	PL2C	1390	PL2F	2500
C (W/Re5-26)	C	2315	F	4200
Pt100	Pt	8500	Pt	9999
JPt100	JPt	850	JPt	1500
	JPtC	5000	JPtF	9000
	JPtC	500	JPtF	900
4 to 20mA DC	420A		420A	
0 to 20mA DC	020A		020A	
0 to 1V DC	0 1V	Scaling high limit value	0 1V	Scaling high limit value
0 to 5V DC	0 5V		0 5V	
1 to 5V DC	1 5V		1 5V	
0 to 10V DC	0 10V		0 10V	

5.1 Setup flow chart

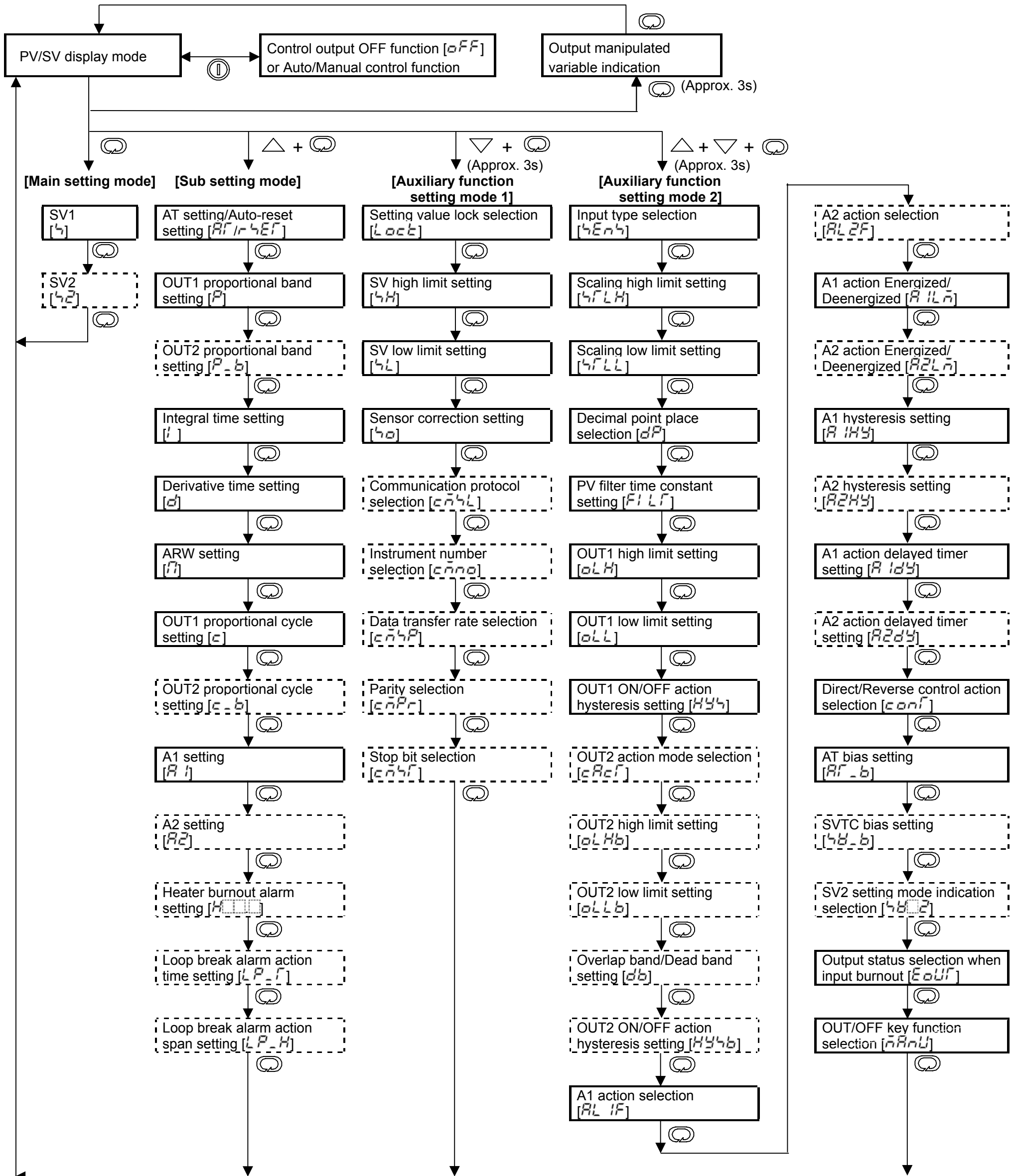

[Key operation]

- △ + (circle with arrow) : Press the (circle with arrow) key while holding down the △ key.
- ▽ + (circle with arrow) (Approx. 3s): Press the (circle with arrow) key for 3 seconds while holding down the ▽ key.
- △ + ▽ + (circle with arrow) (Approx. 3s): Press the (circle with arrow) for 3 seconds while holding down the △ and ▽ keys.

Dotted lines show options, which are indicated only when the options are applied.

5.2 Main setting mode

Character	Name, Function, Setting range	Default value
4	SV1 <ul style="list-style-type: none"> Sets SV1. Setting range: SV low limit to SV high limit 	0°C
42	SV2 <ul style="list-style-type: none"> Sets SV2. Available only when the option SM is applied. Setting range: SV low limit to SV high limit 	0°C

5.3 Sub setting mode

Character	Name, Function, Setting range	Default value
AT r4Er	AT setting/Auto-reset setting <ul style="list-style-type: none"> Designates auto-tuning Performance or auto-reset Performance. If the auto-tuning is cancelled during the process, P, I and D values revert to the former value at which AT is performed. When auto-tuning has not finished after 4 hours, it is cancelled automatically. Auto-reset is cancelled in approximately 4 minutes. 	----
P	OUT1 proportional band setting <ul style="list-style-type: none"> Sets the proportional band for OUT1. OUT1 becomes ON/OFF action when set to 0 or 0.0 0 to 1000°C(2000°F), 0.0 to 999.9°C(°F) or 0.0 to 100.0% 	10°C
P_b	OUT2 proportional band setting <ul style="list-style-type: none"> Sets the proportional band for OUT2. OUT2 becomes ON/OFF action when OUT1 proportional band is set to 0 or 0.0. Not available if option DT is not added or if OUT1 is ON/OFF action. 0.0 to 10.0 times (multiplying factor to OUT1 proportional band) 	1.0 times
I	Integral time setting <ul style="list-style-type: none"> Sets integral time for OUT1. Setting the value to 0 disables the function. Not available when OUT1 is ON/OFF action. Auto-reset can be performed when PD action (I=0). Setting range: 0 to 1000 seconds 	200 seconds
d	Derivative time setting <ul style="list-style-type: none"> Sets derivative time for OUT1. Setting the value to 0 disables the function. Not available when OUT1 is ON/OFF action. Setting range: 0 to 300 seconds 	50 seconds
n	ARW setting <ul style="list-style-type: none"> Sets ARW for OUT1. Available only when PID is the control action. Setting range: 0 to 100% 	50%
c	OUT1 proportional cycle setting <ul style="list-style-type: none"> Sets proportional cycle for OUT1. Not available for DC current output type or when OUT1 is ON/OFF action. Setting range: 1 to 120 seconds 	30 seconds or 3 seconds
c_b	OUT2 proportional cycle setting <ul style="list-style-type: none"> Sets proportional cycle for OUT2. Not available if the option DT is not applied or when OUT2 is ON/OFF action. Setting range: 1 to 120 seconds 	3 seconds
A1	A1 setting <ul style="list-style-type: none"> Sets action point for A1 output. Not available if No alarm action is selected in A1 action selection Refer to (Table 5.3-1). 	0°C
A2	A2 setting <ul style="list-style-type: none"> Sets action point for A2 output. Not available if option A2 is not applied or if No alarm action is selected in A2 action selection. Refer to (Table 5.3-1). 	0°C
H XX.X indicated in turn	Heater burnout alarm setting <ul style="list-style-type: none"> Sets the heater current value for Heater burnout alarm. Self-holding is not available for the alarm output. Available only when the option W is added. Rating 5A : 0.0 to 5.0A Rating 10A: 0.0 to 10.0A Rating 20A: 0.0 to 20.0A Rating 50A: 0.0 to 50.0A 	0.0A

<i>LP_L</i>	Loop break alarm action time setting <ul style="list-style-type: none"> • Sets the time to assess the Loop break alarm. • Available only when the option LA is applied. • Setting range: 0 to 200 minutes 	0 minutes
<i>LP_H</i>	Loop break alarm action span setting <ul style="list-style-type: none"> • Sets the temperature to assess the Loop break alarm. • Available only when the option LA is applied. • Setting range: 0 to 150°C (°F), 0.0 to 150.0°C (°F) or 0 to 1500 	0°C

(Table 5.3-1)

Alarm action type	Setting range	
High limit alarm	– (Input span) to input span°C(°F)	*1
Low limit alarm	– (Input span) to input span°C(°F)	*1
High/Low limits alarm	0 to input span°C(°F)	*1
High/Low limit range alarm	0 to input span°C(°F)	*1
Process high alarm	Input range low limit value to input range high limit value	*2
Process low alarm	Input range low limit value to input range high limit value	*2
High limit alarm with standby	– (Input span) to input span°C(°F)	*1
Low limit alarm with standby	– (Input span) to input span°C(°F)	*1
High/Low limits alarm with standby	0 to input span°C(°F)	*1

• When input has a decimal point, the negative low limit value is –199.9, and the positive high limit value is 999.9.

• All alarm actions except process alarms are \pm deviation setting to the main setting.

*1: For DC input, the input span is the same as the scaling span.

*2: For DC input, input range low (high) limit value is the same as scaling low (high) limit value.

5.4 Auxiliary function setting mode 1

Character	Name, Function, Setting range	Default value
<i>Lock</i>	Setting value lock selection <ul style="list-style-type: none"> • Locks the setting values to prevent setting errors. The setting item to be locked depends on the designation. • When Lock 1 or Lock 2 is designated, PID Auto-tuning and Auto-reset cannot be carried out. • ---- (Unlock): All setting values can be changed. <i>Loc1</i> (Lock 1): None of the setting values can be changed. <i>Loc2</i> (Lock 2): Only main setting value can be changed. <i>Loc3</i> (Lock 3): All setting values can be changed. However, do not change the setting items in the Auxiliary function setting mode 2. They return to their former value after power is turned off because they are not saved in the non-volatile memory. It is suitable to use in combination with our programmable controller (with SVTC) as this has no relation to memory life. 	Unlock
<i>4H</i>	SV high limit setting <ul style="list-style-type: none"> • Sets the SV high limit. • Setting range: SV low limit to input range high limit value or SV low limit to scaling high limit value 	Input range high limit value
<i>4L</i>	SV low limit setting <ul style="list-style-type: none"> • Sets the SV low limit. • Setting range: Input range low limit value to SV high limit or scaling low limit value to SV high limit 	Input range low limit value
<i>40</i>	Sensor correction setting <ul style="list-style-type: none"> • Sets the correction value for the sensor. • Setting range: –100.0 to 100.0°C (°F), or –1000 to 1000 	0.0°C
<i>cñ4L</i>	Communication protocol selection <ul style="list-style-type: none"> • Selects communication protocol. • Available only when the option C5 is applied. • Shinko protocol : <i>ñodñL</i>, Modbus ASCII mode : <i>ñodñA</i>, Modbus RTU mode : <i>ñodñR</i> 	Shinko protocol
<i>cñno</i>	Instrument number setting <ul style="list-style-type: none"> • Sets the instrument number individually to each instrument when communicating by connecting plural instruments in serial communication. • Available only when option C5 is added. • Setting range: 0 to 95 	0
<i>cñ4P</i>	Data transfer rate selection <ul style="list-style-type: none"> • Selects a transfer rate to be equal to the rate of the host computer. • Available only when option [C5] is added. • 2400bps: <i>24</i>, 4800bps: <i>48</i>, 9600bps: <i>96</i>, 19200bps: <i>192</i> 	9600bps

<i>cāPr</i>	Parity selection <ul style="list-style-type: none"> • Selects the parity. • Not available when the option C5 is not added or when Shinko protocol is selected in the Communication protocol selection. • No parity: <i>nonE</i>, Even parity: <i>EBEn</i>, Odd parity: <i>odd</i> 	Even parity
<i>cā4r</i>	Stop bit selection <ul style="list-style-type: none"> • Selects the stop bit. • Not available when option C5 is not added or when Shinko protocol is selected in the Communication protocol selection. • Setting range: 1, 2 	1

5.5 Auxiliary function setting mode 2

Character	Name, Function, Setting range	Default value																																																																																				
<i>4En4</i>	Input type selection <ul style="list-style-type: none"> • The input type can be selected from thermocouple (10 types), RTD (2 types), DC current (2 types) and DC voltage (4 types), and the unit °C/°F can be selected as well. • When changing the input from DC voltage to other inputs, remove the sensor connected to this controller first, then change for the input. If the input is changed with the sensor connected, the input circuit may be broken. 	K (-200 to 1370°C)																																																																																				
	<table border="0"> <tr> <td>K</td> <td>-200 to 1370°C: <i>e L</i></td> <td>K</td> <td>-320 to 2500 °F: <i>e F</i></td> </tr> <tr> <td></td> <td>-199.9 to 400.0°C: <i>e .L</i></td> <td></td> <td>-199.9 to 750.0°F: <i>e .F</i></td> </tr> <tr> <td>J</td> <td>-200 to 1000 °C: <i>J L</i></td> <td>J</td> <td>-320 to 1800 °F: <i>J F</i></td> </tr> <tr> <td>R</td> <td>0 to 1760 °C: <i>r L</i></td> <td>R</td> <td>0 to 3200 °F: <i>r F</i></td> </tr> <tr> <td>S</td> <td>0 to 1760 °C: <i>s L</i></td> <td>S</td> <td>0 to 3200 °F: <i>s F</i></td> </tr> <tr> <td>B</td> <td>0 to 1820 °C: <i>b L</i></td> <td>B</td> <td>0 to 3300 °F: <i>b F</i></td> </tr> <tr> <td>E</td> <td>-200 to 800 °C: <i>E L</i></td> <td>E</td> <td>-320 to 1500 °F: <i>E F</i></td> </tr> <tr> <td>T</td> <td>-199.9 to 400.0°C: <i>T L</i></td> <td>T</td> <td>-199.9 to 750.0°F: <i>T F</i></td> </tr> <tr> <td>N</td> <td>-200 to 1300 °C: <i>n L</i></td> <td>N</td> <td>-320 to 2300 °F: <i>n F</i></td> </tr> <tr> <td>PL-II</td> <td>0 to 1390 °C: <i>PL2L</i></td> <td>PL-II</td> <td>0 to 2500 °F: <i>PL2F</i></td> </tr> <tr> <td>C (W/Re5-26)</td> <td>0 to 2315 °C: <i>c L</i></td> <td>C (W/Re5-26)</td> <td>0 to 4200 °F: <i>c F</i></td> </tr> <tr> <td>Pt100</td> <td>-199.9 to 850.0°C: <i>Pt L</i></td> <td>Pt100</td> <td>-199.9 to 999.9°F: <i>Pt F</i></td> </tr> <tr> <td>JPt100</td> <td>-199.9 to 500.0°C: <i>JPt L</i></td> <td>JPt100</td> <td>-199.9 to 900.0°F: <i>JPt F</i></td> </tr> <tr> <td>Pt100</td> <td>-200 to 850 °C: <i>Pt L</i></td> <td>Pt100</td> <td>-300 to 1500°F: <i>Pt F</i></td> </tr> <tr> <td>JPt100</td> <td>-200 to 500 °C: <i>JPt L</i></td> <td>JPt100</td> <td>-300 to 900 °F: <i>JPt F</i></td> </tr> <tr> <td>4 to 20mA</td> <td>-1999 to 9999: <i>420A</i></td> <td></td> <td></td> </tr> <tr> <td>0 to 20mA</td> <td>-1999 to 9999: <i>020A</i></td> <td></td> <td></td> </tr> <tr> <td>0 to 1V</td> <td>-1999 to 9999: <i>0 1V</i></td> <td></td> <td></td> </tr> <tr> <td>0 to 5V</td> <td>-1999 to 9999: <i>0 5V</i></td> <td></td> <td></td> </tr> <tr> <td>1 to 5V</td> <td>-1999 to 9999: <i>1 5V</i></td> <td></td> <td></td> </tr> <tr> <td>0 to 10V</td> <td>-1999 to 9999: <i>0 10V</i></td> <td></td> <td></td> </tr> </table>	K	-200 to 1370°C: <i>e L</i>	K	-320 to 2500 °F: <i>e F</i>		-199.9 to 400.0°C: <i>e .L</i>		-199.9 to 750.0°F: <i>e .F</i>	J	-200 to 1000 °C: <i>J L</i>	J	-320 to 1800 °F: <i>J F</i>	R	0 to 1760 °C: <i>r L</i>	R	0 to 3200 °F: <i>r F</i>	S	0 to 1760 °C: <i>s L</i>	S	0 to 3200 °F: <i>s F</i>	B	0 to 1820 °C: <i>b L</i>	B	0 to 3300 °F: <i>b F</i>	E	-200 to 800 °C: <i>E L</i>	E	-320 to 1500 °F: <i>E F</i>	T	-199.9 to 400.0°C: <i>T L</i>	T	-199.9 to 750.0°F: <i>T F</i>	N	-200 to 1300 °C: <i>n L</i>	N	-320 to 2300 °F: <i>n F</i>	PL-II	0 to 1390 °C: <i>PL2L</i>	PL-II	0 to 2500 °F: <i>PL2F</i>	C (W/Re5-26)	0 to 2315 °C: <i>c L</i>	C (W/Re5-26)	0 to 4200 °F: <i>c F</i>	Pt100	-199.9 to 850.0°C: <i>Pt L</i>	Pt100	-199.9 to 999.9°F: <i>Pt F</i>	JPt100	-199.9 to 500.0°C: <i>JPt L</i>	JPt100	-199.9 to 900.0°F: <i>JPt F</i>	Pt100	-200 to 850 °C: <i>Pt L</i>	Pt100	-300 to 1500°F: <i>Pt F</i>	JPt100	-200 to 500 °C: <i>JPt L</i>	JPt100	-300 to 900 °F: <i>JPt F</i>	4 to 20mA	-1999 to 9999: <i>420A</i>			0 to 20mA	-1999 to 9999: <i>020A</i>			0 to 1V	-1999 to 9999: <i>0 1V</i>			0 to 5V	-1999 to 9999: <i>0 5V</i>			1 to 5V	-1999 to 9999: <i>1 5V</i>			0 to 10V	-1999 to 9999: <i>0 10V</i>			
K	-200 to 1370°C: <i>e L</i>	K	-320 to 2500 °F: <i>e F</i>																																																																																			
	-199.9 to 400.0°C: <i>e .L</i>		-199.9 to 750.0°F: <i>e .F</i>																																																																																			
J	-200 to 1000 °C: <i>J L</i>	J	-320 to 1800 °F: <i>J F</i>																																																																																			
R	0 to 1760 °C: <i>r L</i>	R	0 to 3200 °F: <i>r F</i>																																																																																			
S	0 to 1760 °C: <i>s L</i>	S	0 to 3200 °F: <i>s F</i>																																																																																			
B	0 to 1820 °C: <i>b L</i>	B	0 to 3300 °F: <i>b F</i>																																																																																			
E	-200 to 800 °C: <i>E L</i>	E	-320 to 1500 °F: <i>E F</i>																																																																																			
T	-199.9 to 400.0°C: <i>T L</i>	T	-199.9 to 750.0°F: <i>T F</i>																																																																																			
N	-200 to 1300 °C: <i>n L</i>	N	-320 to 2300 °F: <i>n F</i>																																																																																			
PL-II	0 to 1390 °C: <i>PL2L</i>	PL-II	0 to 2500 °F: <i>PL2F</i>																																																																																			
C (W/Re5-26)	0 to 2315 °C: <i>c L</i>	C (W/Re5-26)	0 to 4200 °F: <i>c F</i>																																																																																			
Pt100	-199.9 to 850.0°C: <i>Pt L</i>	Pt100	-199.9 to 999.9°F: <i>Pt F</i>																																																																																			
JPt100	-199.9 to 500.0°C: <i>JPt L</i>	JPt100	-199.9 to 900.0°F: <i>JPt F</i>																																																																																			
Pt100	-200 to 850 °C: <i>Pt L</i>	Pt100	-300 to 1500°F: <i>Pt F</i>																																																																																			
JPt100	-200 to 500 °C: <i>JPt L</i>	JPt100	-300 to 900 °F: <i>JPt F</i>																																																																																			
4 to 20mA	-1999 to 9999: <i>420A</i>																																																																																					
0 to 20mA	-1999 to 9999: <i>020A</i>																																																																																					
0 to 1V	-1999 to 9999: <i>0 1V</i>																																																																																					
0 to 5V	-1999 to 9999: <i>0 5V</i>																																																																																					
1 to 5V	-1999 to 9999: <i>1 5V</i>																																																																																					
0 to 10V	-1999 to 9999: <i>0 10V</i>																																																																																					
<i>4FLH</i>	Scaling high limit setting <ul style="list-style-type: none"> • Sets scaling high limit value. • Available only for DC inputs • Setting range: Scaling low limit value to input range high limit value 	9999																																																																																				
<i>4FLl</i>	Scaling low limit setting <ul style="list-style-type: none"> • Sets scaling low limit value. • Available only for DC inputs • Setting range: Input range low limit value to scaling high limit value 	-1999																																																																																				
<i>dP</i>	Decimal point place selection <ul style="list-style-type: none"> • Selects decimal point place. • Available only for DC inputs • No decimal point: <i>0000</i> 1 digit after decimal point: <i>0000</i> • 2 digits after decimal point: <i>0000</i> 3 digits after decimal point: <i>0000</i> 	No decimal point																																																																																				
<i>FILF</i>	PV filter time constant setting <ul style="list-style-type: none"> • Sets PV filter time constant. (If the value is set too large, it affects control result due to the delay of response) • Setting range: 0.0 to 10.0 seconds 	0.0 seconds																																																																																				
<i>oLH</i>	OUT1 high limit setting <ul style="list-style-type: none"> • Sets the high limit value of OUT1. • Not available when OUT1 is ON/OFF action • Setting range: OUT1 low limit value to 105% (Setting greater than 100% is effective to DC current output type) 	100%																																																																																				

<i>oLL</i>	OUT1 low limit setting <ul style="list-style-type: none"> Sets the low limit value of OUT1. Not available when OUT1 is ON/OFF action. Setting range: -5% to OUT1 high limit value (Setting less than 0% is effective to DC current output type) 	0%
<i>H34</i>	OUT1 ON/OFF action hysteresis setting <ul style="list-style-type: none"> Sets ON/OFF action hysteresis for OUT1. Available only when OUT1 is ON/OFF action Setting range: 0.1 to 100.0°C (°F), or 1 to 1000 	1.0°C
<i>cARf</i>	OUT2 action mode selection <ul style="list-style-type: none"> Selects OUT2 action from air, oil and water coolings. Not available when the option DT is not added or when OUT2 is ON/OFF action Air cooling: <i>Air</i>, oil cooling: <i>oil</i>, water cooling: <i>WAR</i> 	Air cooling
<i>oLHb</i>	OUT2 high limit setting <ul style="list-style-type: none"> Sets the high limit value of OUT2. Not available when the option DT is not added or when OUT2 is ON/OFF action Setting range: OUT2 low limit value to 105% (Setting greater than 100% is effective to DC current output type) 	100%
<i>oLLb</i>	OUT2 low limit setting <ul style="list-style-type: none"> Sets the low limit value of OUT2. Not available when the option DT is not added or when OUT2 is ON/OFF action Setting range: -5% to OUT2 high limit value (Setting less than 0% is effective to DC current output type) 	0%
<i>db</i>	Overlap band/Dead band setting <ul style="list-style-type: none"> Sets the overlap band or dead band for OUT1 and OUT2. + setting value: Dead band, - setting value: Overlap band Available only when the option DT is added Setting range: -100.0 to 100.0°C (°F), or 1 to 1000 	0°C
<i>H34b</i>	OUT2 ON/OFF action hysteresis setting <ul style="list-style-type: none"> Sets ON/OFF action hysteresis for OUT2. Available only when the option DT is added Setting range: 0.1 to 100.0°C (°F), or 1 to 1000 	1.0°C
<i>ALIF</i>	A1 action selection <ul style="list-style-type: none"> Selects an action for A1. <pre> No alarm action : ---- Process high alarm : AH High limit alarm : H Process low alarm : rAH Low limit alarm : L High limit alarm w/standby: H u H/L limits alarm : HL Low limit alarm w/standby: L u H/L limit range alarm: uld H/L limits alarm w/standby: HL u </pre>	No alarm action
<i>AL2F</i>	A2 action selection <ul style="list-style-type: none"> Selects an action for A2. Available only when alarm A2 is added Action selection and default value are the same as those of A1 action selection. 	No alarm action
<i>A1Lā</i>	A1 action Energized/Deenergized selection <ul style="list-style-type: none"> Selects Energized/Deenergized for A1. Not available if No alarm action is selected in A1 action selection Energized: <i>noAL</i> Deenergized: <i>rEB4</i> 	Energized
<i>A2Lā</i>	A2 action Energized/Deenergized selection <ul style="list-style-type: none"> Selects Energized/Deenergized for A2. Not available if alarm A2 is not added or if No alarm action is selected in A2 action selection Action selection and default value are the same as those of A1 action Energized/Deenergized selection. 	Energized
<i>A1H4</i>	A1 hysteresis setting <ul style="list-style-type: none"> Sets hysteresis for A1. Not available if No alarm action is selected in A1 action selection Setting range: 0.1 to 100.0°C(°F), or 1 to 1000 	1.0°C
<i>A2H4</i>	A2 hysteresis setting <ul style="list-style-type: none"> Sets hysteresis for A2. Not available if alarm A2 is not added or if No alarm action is selected in A2 action selection Setting range: 0.1 to 100.0°C(°F), or 1 to 1000 	1.0°C

<i>R1d4</i>	A1 action delayed timer setting • Sets action delayed timer for A1. When setting time has passed after the input enters the alarm output range, the alarm is activated. • Not available if No alarm action is selected in A1 action selection • Setting range: 0 to 9999 seconds	0 seconds
<i>R2d4</i>	A2 action delayed timer setting • Sets action delayed timer for A2. When setting time has passed after the input enters the alarm output range, the alarm is activated. • Not available if alarm A2 is not added or if No alarm action is selected in A2 action selection • Setting range: 0 to 9999 seconds	0 seconds
<i>conf</i>	Direct/ Reverse action selection • Selects Reverse (Heating) or Direct (Cooling) action. • Reverse (Heating): <i>HEAT</i> Direct (Cooling): <i>COOL</i>	Reverse (Heating) action
<i>Rf_b</i>	AT bias setting • Sets bias value during PID auto-tuning. • Not available for DC inputs • Setting range: 0 to 50°C(0 to 100°F) or 0.0 to 50.0°C(0.0 to 100.0°F)	20°C
<i>48_b</i>	SVTC bias setting • Control desired value adds SVTC bias value to the value received by the SVTC command. • Available only when option C5 is added • Converted value of $\pm 20\%$ of the rated value or $\pm 20\%$ of the scaling range	0
<i>482</i>	SV2 indication selection • Selects whether SV2 setting item is indicated or not. • Available only when the option SM is added. • <i>OFF</i> (No indication), <i>ON</i> (Indication)	No indication
<i>Eouf</i>	Output status selection when input burnout • Selects whether OUT1 is turned OFF or not when DC input is overscale or underscale. • Available only for DC current output type with DC inputs • <i>OFF</i> (Output OFF), <i>ON</i> (Output ON)	Output OFF
<i>ARnU</i>	OUT/OFF key function selection • Selects whether OUT/OFF key is used for control output OUT/OFF function or for Auto/Manual control function. • <i>OFF</i> (OUT/OFF function) <i>ARnU</i> (Auto/Manual control function)	OUT/OFF function

Sensor correction function

This corrects the input value from the sensor. When a sensor cannot be set at a location where control is desired, the sensor measuring temperature may deviate from the temperature in the controlled location. When controlling with plural controllers, sometimes the temperatures measured (input value) do not concur with the same setting value due to difference in sensor accuracy or dispersion of load capacities. In such a case, the control can be set at the desired temperature by adjusting the input value of sensors.

Energized/Deenergized

When [alarm action energized] is selected, the alarm output (between terminals 3-4, or 3-5) is conducted (ON) while the alarm output indicator is lit. The alarm output is not conducted (OFF) while the alarm output indicator is not lit.

When [alarm action deenergized] is selected, the alarm output (between terminals 3-4, or 3-5) is not conducted (OFF) while the alarm output indicator is lit. The alarm output is conducted (ON) while the alarm output indicator is not lit.

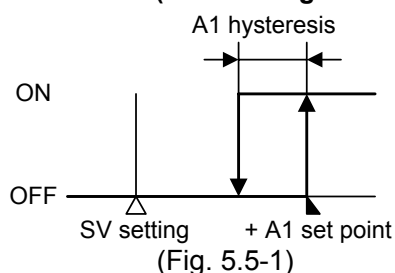

High limit alarm (when Energized is set)

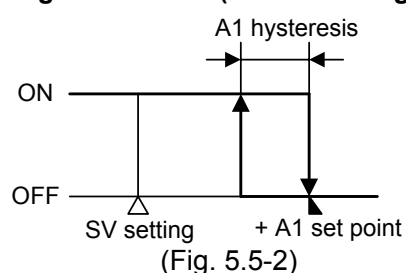

High limit alarm (when Deenergized is set)





5.6 Auto/Manual control function

Name, Functions	
Auto/Manual control function	
<ul style="list-style-type: none"> If Auto/Manual control function is selected in the OUT/OFF key function selection, Automatic or Manual control function can be switched by pressing the  key in the PV/SV display mode. If control action is switched from automatic to manual or vice versa, balanceless-bumpless function works to prevent sudden change of manipulated variable. When automatic control is switched to manual control, the 1st dot from the right on the SV display blinks, and the output manipulated variable (MV) can be increased or decreased by pressing \triangle or ∇ key to perform the control. By pressing the  key again, the mode reverts to the PV/SV display mode (automatic control). (Whenever the power to the controller is turned on, automatic control starts.) 	

5.7 Control output OFF function

Character	Name, Functions
OFF	Control output OFF function <ul style="list-style-type: none"> A function to pause the control action or turn the control output of the unused instrument of the plural units OFF even if the power to the instrument is supplied. [OFF] is indicated on the PV display while the function is working. Once the control output OFF function is enabled, the function cannot be released even if the power to the instrument is turned OFF and ON again. To cancel the function, press the  key again for approx. 1 second.

5.8 Output manipulated variable (MV) indication

Name and functions	
Output manipulated variable indication	
<ul style="list-style-type: none"> In the PV/SV display mode, press the  key for approx. 3 seconds. Keep pressing the  key until the output manipulated variable shows up, though the main setting mode appears temporarily during the process. (The SV display indicates output manipulated variable and the decimal point blinks at a cycle of every 0.5 second). If the  key is pressed again, the mode reverts to the PV/SV display. 	

6. Running

After the controller has been mounted to the control panel and wiring is completed, it can be started in the following manner.

(1) Turn the power supply to the JCS-33A ON.

Turn the power supply to the JCS-33A ON.

- For approx. 3s after the power is switched ON, the sensor input character and the temperature unit are indicated on the PV display and input range high limit value is indicated on the SV display. See (Table 5-1). (If any other value has been set in the scaling high limit setting, the set value is indicated on the SV display) During this time, all outputs and LED indicators are in OFF status.
- After that, control starts indicating input value on the PV display, and main setting value on the SV display.
- While the Control output OFF function is working, OFF is indicated on the PV display.

(2) Input each setting value. Input each setting value, referring to "5. Setup".

(3) Turn the load circuit power ON.

Starts the control action so as to keep the controlled object at the main setting value.

7. Action explanation

7.1 OUT1 action

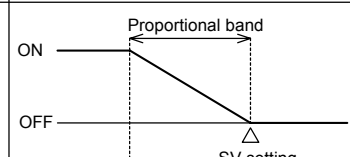
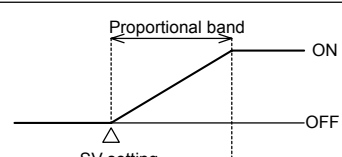
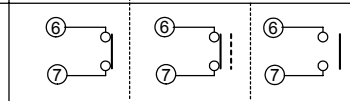
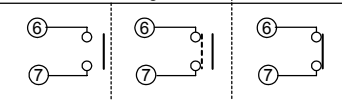
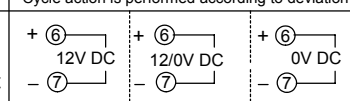
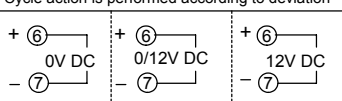
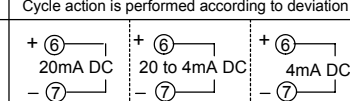
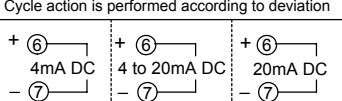
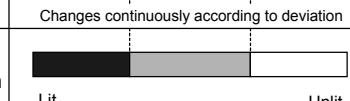
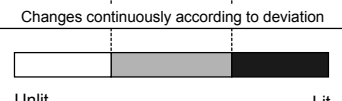
	Heating (Reverse) action			Cooling (Direct) action		
Control action						
Relay contact output	 <p>Cycle action is performed according to deviation</p>			 <p>Cycle action is performed according to deviation</p>		
Non-contact voltage output	 <p>Cycle action is performed according to deviation</p>			 <p>Cycle action is performed according to deviation</p>		
DC current output	 <p>Changes continuously according to deviation</p>			 <p>Changes continuously according to deviation</p>		
Indication (OUT1) Green	 <p>Lit Unlit</p>			 <p>Unlit Lit</p>		

 part : Acts ON or OFF.

7.2 EVT (Heater burnout alarm) action

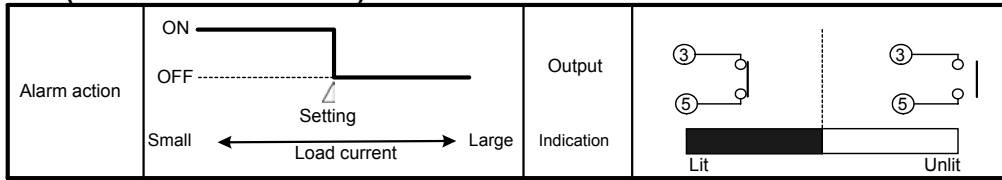

7.3 OUT1 ON/OFF action

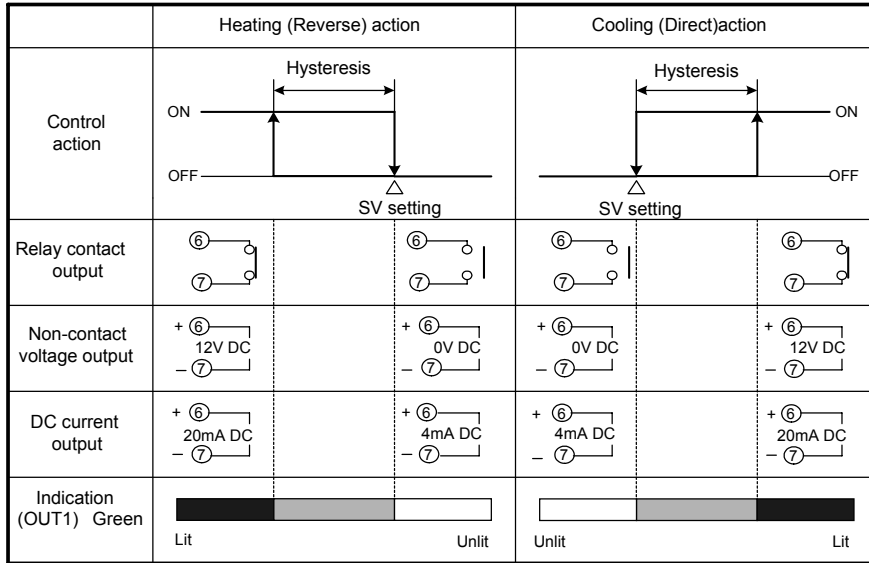

7.4 Temperature alarm action

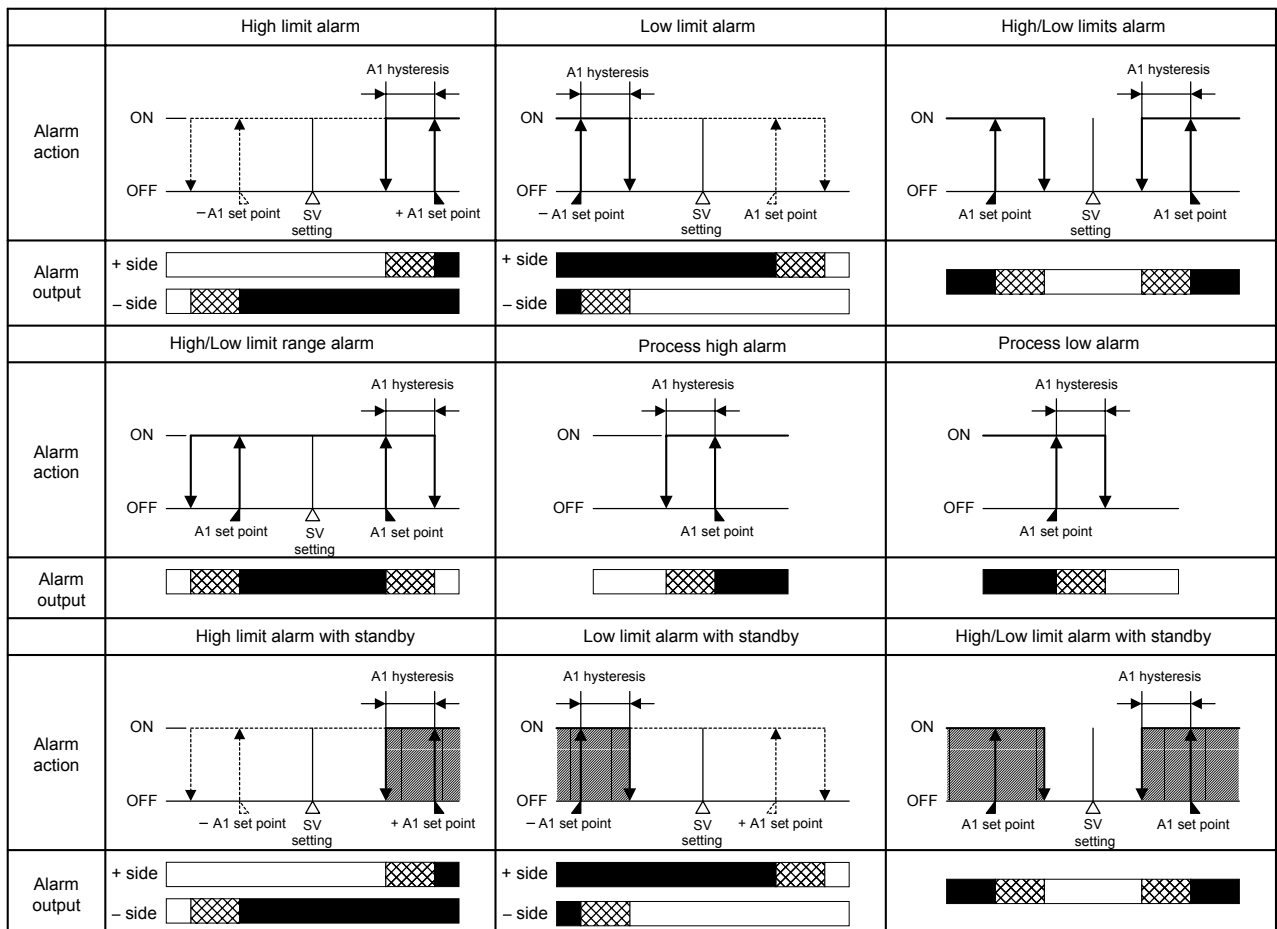

- : Alarm output terminals between 3 and 4 is ON.
- : Alarm output terminals between 3 and 4 is ON or OFF.
- : Alarm output terminals between 3 and 4 is OFF.
- : Standby functions in this section.

A1 indicator lights up when output terminals between 3 and 4 is ON, and goes out when between them is OFF.

7.5 OUT2 (Heating/Cooling control) action

Control action			
Relay contact output (OUT1)	<p>Cycle action is performed according to deviation.</p>		
Non-contact voltage output (OUT1)	<p>Cycle action is performed according to deviation.</p>		
DC current output (OUT1)	<p>Changes continuously according to deviation.</p>		
Non-contact relay output (OUT2)	<p>Cycle action is performed according to deviation.</p>		
Indication (OUT1) Green			
Indication (OUT2) Yellow			

: Acts ON (lit) or OFF (unlit).
 : Represents Heating control action.
 : Represents Cooling control action.

7.6 OUT2 (Heating/Cooling control) action (When setting Dead band)

Control action			
Relay contact output (OUT1)	<p>Cycle action is performed according to deviation.</p>		
Non-contact voltage output (OUT1)	<p>Cycle action is performed according to deviation.</p>		
DC current output (OUT1)	<p>Changes continuously according to deviation.</p>		
Non-contact relay output (OUT2)	<p>Cycle action is performed according to deviation.</p>		
Indication (OUT1) Green			
Indication (OUT2) Yellow			

: Acts ON (lit) or OFF (unlit).
 : Represents Heating control action.
 : Represents Cooling control action.

7.7 OUT2 (Heating/Cooling control) action (When setting Overlap band)

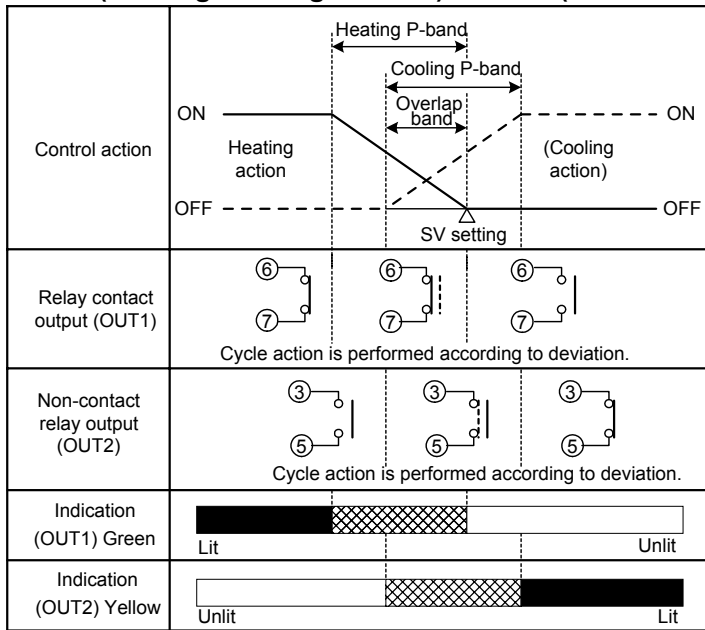

: Acts ON (lit) or OFF (unlit).
 — : Represents Heating control action.
 - - - : Represents Cooling control action.

8. PID auto-tuning of this controller

In order to set each value of P, I, D and ARW automatically, fluctuation is applied to the controlled object to get an optimal value. One of 3 types of fluctuation below is automatically selected.

(1) When the difference between the setting value and processing temperature is large as the temperature rises.

When AT bias is set to 20°C(°F), fluctuation is applied at the temperature 20°C lower than the setting value.

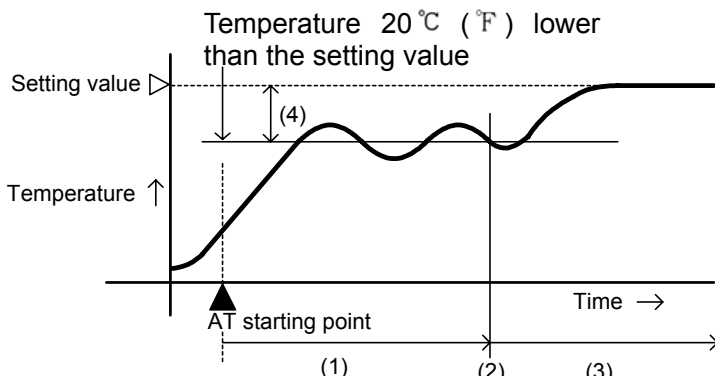

- (1) Calculating PID constant
- (2) PID constant calculated
- (3) Controlled by the PID constant set by auto-tuning.
- (4) AT bias value

(2) When the control is stable or when control temperature is within ±20°C(°F) of setting value.

Fluctuation is applied at the setting value.

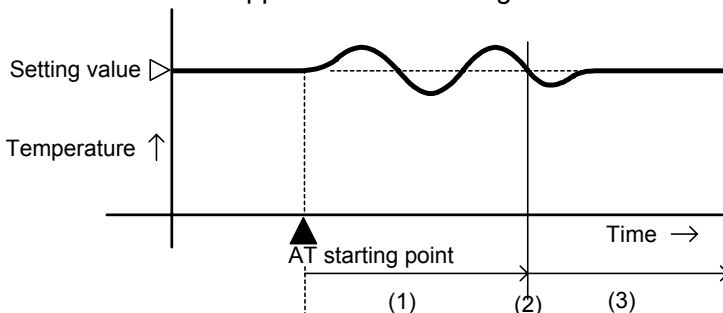

- (1) Calculating PID constant
- (2) PID constant calculated
- (3) Controlled by the PID constant set by auto-tuning.

(3) When the control temperature is 20°C (°F) or higher than the setting value.

When AT bias is set to 20°C (°F), fluctuation is applied at the temperature 20°C (°F) higher than the setting value.

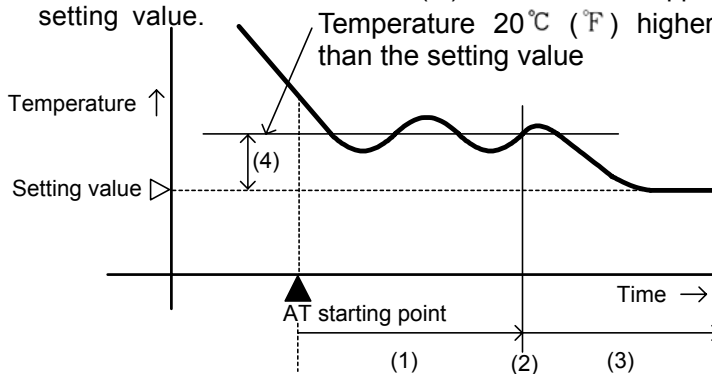

- (1) Calculating PID constant
- (2) PID constant calculated
- (3) Controlled by the PID constant set by auto-tuning.
- (4) AT bias value

9. Specifications

9.1 Standard specifications

Mounting method : Flush

Setting method : Input system using membrane sheet key

Display PV display : Red LED 4 digits, character size 10.2 x 4.9 mm (H x W)
SV display : Green LED 4 digits, character size 8.8 x 4.9 mm (H x W)

Accuracy (Setting and Indication):

Thermocouple : Within $\pm 0.2\%$ of each input span ± 1 digit, or within $\pm 2^\circ\text{C}$ (4°F), whichever is greater

However R, S inputs, 0 to 200°C (400°F): Within $\pm 6^\circ\text{C}$ (12°F)

B input, 0 to 300°C (600°F): Accuracy is not guaranteed

K, J, E, T, N inputs, less than 0°C (32°F): Within $\pm 0.4\%$ of input span ± 1 digit

RTD : Within $\pm 0.1\%$ of each input span ± 1 digit, or within $\pm 1^\circ\text{C}$ (2°F), whichever is greater

DC current : Within $\pm 0.2\%$ of each input span ± 1 digit

DC voltage : Within $\pm 0.2\%$ of each input span ± 1 digit

Input sampling period : 0.25 seconds

Input Thermocouple : K, J, R, S, B, E, T, N, PL-II, C(W/Re5-26) External resistance, 100Ω or less (However, B input: External resistance, 40Ω or less)

RTD : Pt100, JPt100, 3-wire system

Allowable input lead wire resistance (10Ω or less per wire)

DC current : 0 to 20mA DC, 4 to 20mA DC

Input impedance: External shunt resistor 50Ω

Allowable input current (50mA or less)

DC voltage : 0 to 1V DC Input impedance ($1M\Omega$ or greater)

Allowable input voltage (5V or less)

Allowable signal source resistance ($2k\Omega$ or less)

: 0 to 5V DC, 1 to 5V DC, 0 to 10V DC Input impedance ($100k\Omega$ or greater)

Allowable input voltage (15V or less)

Allowable signal source resistance (100Ω or less)

OUT1 output

Relay contact : 1a, Control capacity 3A 250V AC (resistive load)

1A 250V AC (inductive load $\cos\phi=0.4$)

Electrical life, 100,000 times

Non-contact voltage (For SSR drive): 12^{+2}_0V DC maximum 40mA (short circuit protected)

DC current : 4 to 20mA DC, Load resistance, maximum 550Ω

A1 output

Action : ON/OFF action

Hysteresis : 0.1 to 100.0°C ($^\circ\text{F}$), or 1 to 1000

Output : Relay contact 1a

Control capacity, 3A 250V AC (resistive load)

Electrical life, 100,000 times

Control action

PID action (with auto-tuning function)

PI action: When derivative time is set to 0

PD action (with auto reset function): When integral time is set to 0

P action (with auto reset function): When derivative and integral times are set to 0.

ON/OFF action: When proportional band is set to 0 or 0.0

OUT1 proportional band : 0 to 1000°C (2000°F), 0.0 to 999.9°C ($^\circ\text{F}$) or 0.0 to 100.0% (ON/OFF action when set to 0 or 0.0)

Integral time : 0 to 1000s (OFF when set to 0)

Derivative time : 0 to 300s (OFF when set to 0)

OUT1 proportional cycle : 1 to 120s (Not available for DC current output type)

ARW : 0 to 100%

OUT1 ON/OFF action hysteresis: 0.1 to 100.0°C ($^\circ\text{F}$), or 1 to 1000

OUT1 high limit setting : 0 to 100% (DC current output type: -5 to 105%)

OUT1 low limit setting : 0 to 100% (DC current output type: -5 to 105%)

Circuit isolation configuration

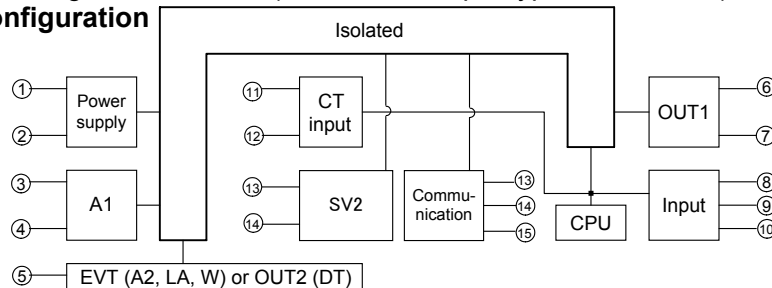

When OUT1 is non-contact voltage output or DC current output, between OUT1 and communication and between OUT1 and SV2 are non-isolated and isolation test **must not** be carried out between them.

- Isolation resistance** : 10M Ω or greater at 500V DC
Dielectric strength : 1.5kV AC for 1minute between input terminal and power terminal
 1.5kV AC for 1minute between output terminal and power terminal
Supply voltage : 100 to 240V AC 50/60Hz, 24V AC/DC 50/60Hz
Allowable voltage fluctuation 100 to 240V AC: 85 to 264V, AC 24V AC/DC: 20 to 28V AC/DC
Power consumption : Approx. 8VA
Ambient temperature : 0 to 50 $^{\circ}$ C (32 to 122 $^{\circ}$ F)
Ambient humidity : 35 to 85%RH (no condensation)
Weight : Approx. 200g
External dimension : 48 x 48 x 95mm (W x H x D)
Material : Flame resistant resin (Case)
Color : Light gray (Case)
Attached functions : **[Setting value lock], [Sensor correction], [Auto/manual control switching], [Input burnout indication]**

Thermocouple and RTD inputs

If the input value exceeds the Indication range high limit value, the PV display blinks “ - - - - ”, and if the input value exceeds the Indication range low limit value, the PV display blinks “ - - - - ”. If the input value exceeds the Control range, OUT1 and OUT2 are turned off (for DC current output type, OUT1 low limit value and OUT2 low limit value). (However, for manual control, it outputs the preset manipulated variable)

Input	Input range	Indication range	Control range
K, T	-199.9 to 400.0 $^{\circ}$ C	-199.9 to 450.0 $^{\circ}$ C	-205.0 to 450.0 $^{\circ}$ C
	-199.9 to 750.0 $^{\circ}$ F	-199.9 to 850.0 $^{\circ}$ F	-209.0 to 850.0 $^{\circ}$ F
K	-200 to 1370 $^{\circ}$ C	-250 to 1420 $^{\circ}$ C	-250 to 1420 $^{\circ}$ C
	-320 to 2500 $^{\circ}$ F	-370 to 2550 $^{\circ}$ F	-370 to 2550 $^{\circ}$ F
J	-200 to 1000 $^{\circ}$ C	-250 to 1050 $^{\circ}$ C	-250 to 1050 $^{\circ}$ C
	-320 to 1800 $^{\circ}$ F	-370 to 1850 $^{\circ}$ F	-370 to 1850 $^{\circ}$ F
R, S	0 to 1760 $^{\circ}$ C	-50 to 1810 $^{\circ}$ C	-50 to 1810 $^{\circ}$ C
	0 to 3200 $^{\circ}$ F	-50 to 3250 $^{\circ}$ F	-50 to 3250 $^{\circ}$ F
B	0 to 1820 $^{\circ}$ C	-50 to 1870 $^{\circ}$ C	-50 to 1870 $^{\circ}$ C
	0 to 3300 $^{\circ}$ F	-50 to 3350 $^{\circ}$ F	-50 to 3350 $^{\circ}$ F
E	-200 to 800 $^{\circ}$ C	-250 to 850 $^{\circ}$ C	-250 to 850 $^{\circ}$ C
	-320 to 1500 $^{\circ}$ F	-370 to 1550 $^{\circ}$ F	-370 to 1550 $^{\circ}$ F
N	-200 to 1300 $^{\circ}$ C	-250 to 1350 $^{\circ}$ C	-250 to 1350 $^{\circ}$ C
	-320 to 2300 $^{\circ}$ F	-370 to 2350 $^{\circ}$ F	-370 to 2350 $^{\circ}$ F
PL-II	0 to 1390 $^{\circ}$ C	-50 to 1440 $^{\circ}$ C	-50 to 1440 $^{\circ}$ C
	0 to 2500 $^{\circ}$ F	-50 to 2550 $^{\circ}$ F	-50 to 2550 $^{\circ}$ F
C(W/Re5-26)	0 to 2315 $^{\circ}$ C	-50 to 2365 $^{\circ}$ C	-50 to 2365 $^{\circ}$ C
	0 to 4200 $^{\circ}$ F	-50 to 4250 $^{\circ}$ F	-50 to 4250 $^{\circ}$ F
Pt100	-199.9 to 850.0 $^{\circ}$ C	-199.9 to 900.0 $^{\circ}$ C	-210.0 to 900.0 $^{\circ}$ C
	-200 to 850 $^{\circ}$ C	-210 to 900 $^{\circ}$ C	-210 to 900 $^{\circ}$ C
	-199.9 to 999.9 $^{\circ}$ F	-199.9 to 999.9 $^{\circ}$ F	-211.0 to 1099.9 $^{\circ}$ F
	-300 to 1500 $^{\circ}$ F	-318 to 1600 $^{\circ}$ F	-318 to 1600 $^{\circ}$ F
JPt100	-199.9 to 500.0 $^{\circ}$ C	-199.9 to 550.0 $^{\circ}$ C	-206.0 to 550.0 $^{\circ}$ C
	-200 to 500 $^{\circ}$ C	-206 to 550 $^{\circ}$ C	-206 to 550 $^{\circ}$ C
	-199.9 to 900.0 $^{\circ}$ F	-199.9 to 999.9 $^{\circ}$ F	-211.0 to 999.9 $^{\circ}$ F
	-300 to 900 $^{\circ}$ F	-312 to 1000 $^{\circ}$ F	-312 to 1000 $^{\circ}$ F

DC current and voltage inputs (4 to 20mA DC, 0 to 20mA DC, 0 to 1V DC, 0 to 5V DC, 1 to 5V DC, 0 to 10V DC)

If input value exceeds Indication range high limit value, PV display blinks “ - - - - ”, and if input value exceeds the Indication low limit range, the PV display blinks “ - - - - ”.

If input value exceeds the Control range, OUT1 and OUT2 are turned ON or OFF, depending on which has been selected in the [Output status selection when input burnout] (for DC current output type, OUT1 high or low limit value, OUT2 high or low limit value). However, for manual control, it outputs the preset manipulated variable.

Indication range : [Scaling low limit value – Scaling span x 1%] to [Scaling high limit value + Scaling span x 10%]
 (If the input value exceeds the range -1999 to 9999, the PV display blinks “ - - - - ” or “ - - - - ”)

Control range : [Scaling low limit value – Scaling span x 1%] to [Scaling high limit value + Scaling span x 10%]

DC input burnout: When DC input is burnt out, PV display blinks “ - - - - ” for 4 to 20mA DC and 1 to 5V DC inputs, and “ - - - - ” for 0 to 1V DC input.

For 0 to 20mA DC, 0 to 5V DC and 0 to 10V DC inputs, the PV display indicates the corresponding value with which 0mA or 0V is inputted.

[Burnout]

When the thermocouple or RTD input is burnt out, OUT1 and OUT2 are turned off (for DC current output type, OUT1 low limit value, OUT2 low limit value) and PV display blinks “ ”.

[Self-diagnosis]

The CPU is monitored by a watchdog timer, and when any abnormal status is found on the CPU, the controller is switched to warm-up status.

[Automatic cold junction temperature compensation] (Only thermocouple input type)

This detects the temperature at the connecting terminal between the thermocouple and the instrument, and always keeps it set to the same status as when the reference junction is located at 0°C (32°F).

[Power failure countermeasure] The setting data is backed up in the non-volatile IC memory.

[Warm-up indication]

After the power supply to the instrument is turned on, the sensor input character and temperature unit are indicated on the PV display and rated scale high limit value is indicated on the SV display for 3 seconds.

For DC current and voltage inputs, the scaling high limit value is indicated.

Accessories included: Screw type mounting bracket 1 set, Instruction manual 1 copy
CT (Current transformer) CTL-6S 1 piece(for rating 5A, 10A, 20A)
CTL-12-S36-10L1 1 piece (for rating 50A)

9.2 Optional specifications

Alarm 2 (A2) (Option code: A2)

The output terminals will be common when the options [W] and [LA] are added together.

Action : ON/OFF action

Hysteresis: 0.1 to 100.0°C (°F), or 1 to 1000

Output : Relay contact 1a

Control capacity, 3A 250V AC (Resistive load)

Electrical life, 100,000 times

Loop break alarm (Option code: LA)

When MV (manipulated variable) is maximum or minimum and when the PV does not change as much as the preset span within the Loop break alarm assessment time, the alarm is activated.

This also detects the breaking status on the loop such as heater burnout, sensor burnout or actuator trouble.

The output terminals will be common if the options [W] and [A2] are applied together.

Setting range : Loop break alarm action time, 0 to 200minutes

Loop break alarm action span, 0 to 150°C(°F), 0.0 to 150.0°C(°F), 0 to 1500

Output : Relay contact 1a

Control capacity, 3A 250V AC (Resistive load)

Electrical life, 100,000 times

Heater burnout alarm (including sensor burnout alarm) (Option code: W)

Monitors heater current with CT (current transformer), and detects burnout.

The output terminals will be common if the options [LA] and [A2] are applied with it.

This option cannot be applied to DC current output type.

Rating : 5A [W(5A)], 10A [W(10A)], 20A [W(20A)], 50A [W(50A)] (Must be specified)

Setting range : 5A [W(5A)], 0.0 to 5.0A (Off when set to 0.0)

10A [W(10A)], 0.0 to 10.0A (Off when set to 0.0)

20A [W(20A)], 0.0 to 20.0A (Off when set to 0.0)

50A [W(50A)], 0.0 to 50.0A (Off when set to 0.0)

Setting accuracy: Within ±5% of the rated value

Action : ON/OFF action

Output : Relay contact 1a

Control capacity, 3A 250V AC (resistive load)

Electrical life, 100,000 times

Heating/Cooling control (Option code: DT)

The specification of Heating side is the same as that of OUT1.

OUT2 proportional band: 0.0 to 10.0 times OUT1 proportional band (ON/OFF action when set to 0.0)

OUT2 integral time : The same as that of OUT1.

OUT2 derivative time : The same as that of OUT1.

OUT2 proportional cycle: 1 to 120 seconds

Overlap band/Dead band setting range:

Thermocouple, RTD inputs: -100.0 to 100.0°C (°F)

DC current, DC voltage inputs: -1000 to 1000 (The placement of the decimal point follows the selection)

Output: Non-contact relay output 0.3A 250V AC

Cooling action mode selection function:

One cooling action can be selected from Air cooling (linear characteristic), Oil cooling (1.5th power of the linear characteristic) and Water cooling (2nd power of the linear characteristic) by key operation.

Serial communication (Option code: C5)

When this option is added, the option [SM] cannot be added with it.

The following operations can be carried out from the external computer.

(1) Reading and setting of the main setting value, PID values and each setting value

(2) Reading of the input value and action status

(3) Change of the functions

- Communication interface : Based on EIA RS-485
- Communication method : Half-duplex start stop synchronous
- Data transfer rate : 2400, 4800, 9600, 19200bps (Selectable by key)
- Parity : Even, Odd and No (Selectable by key)
- Stop bit : 1 and 2 (Selectable by key)
- Communication protocol : Shinko protocol, Modbus RTU, Modbus ASCII (Key selectable)
- Number of units connectable: Maximum 31 units to 1 host computer
- Communication error detection: Double detection by parity and checksum
- Digital external setting : The SV from the programmable controller (with the option SVTC) can be digitally transmitted to the JCS-33A (with the option C5).
(The Setting value lock of the JCS-33A must be set to Lock 3)
When the data from the programmable controller exceeds the SV high limit or low limit value, the JCS-33A ignores the value, and performs the control with the former value.
The control desired value adds SVTC bias value to the value received by the SVTC command.

SV1/SV2 external selection (Option code: SM)

SV1 or SV2 can be selected by the external contact.

When this option is added, the option [C5] cannot be added with it.

Contact open between 13-14: SV1, Contact closed between 13-14: SV2

Contact current: 6mA

Color Black (Option code: BK) Front panel frame and case: Black

Terminal cover (Option code: TC): Electrical shock protecting terminal cover

10. Troubleshooting

If any malfunctions occur, refer to the following items after checking the power supply to the controller.

10.1 Indication

Problem	Presumed cause and solution
PV display is indicating [OFF].	<ul style="list-style-type: none"> • Control output OFF function is working. Press the  key for approx. 1 second to release the function.
[----] is blinking on the PV display.	<ul style="list-style-type: none"> • Thermocouple, RTD or DC voltage (0 to 1V DC) is burnt out. Change each sensor. How to check sensor burnout [Thermocouple] If the input terminal of the instrument is shorted, and if nearby room temperature is indicated, the instrument should be normal and sensor may be burnt out. [RTD] If approx. 100Ω of resistance is connected to the input terminals between A-B of the instrument and between B-B is shorted, then if nearby 0°C (32°F) is indicated, the instrument should be normal and sensor may be burnt out. [DC voltage (0 to 1V DC)] If the input terminal of the instrument is shorted, and if scaling low limit value is indicated, the instrument should be normal and the signal wire may be burnt out. • Is the input terminal of thermocouple, RTD or DC voltage (0 to 1V DC) securely mounted to the instrument input terminal? Connect the sensor terminals to the instrument input terminals securely.
[----] is blinking on the PV display.	<ul style="list-style-type: none"> • Check if input signal source for DC voltage (1 to 5V DC) or DC current (4 to 20mA DC) is normal. How to check each signal wire [DC voltage (1 to 5V DC)] If the input to the input terminals of the instrument is 1V DC and if scaling low limit value is indicated, the instrument should be normal and the signal wire may be disconnected. [DC current (4 to 20mA DC)] If the input to the input terminals of the instrument is 4mA DC and if scaling low limit value is indicated, the instrument should be normal and the signal wire may be disconnected. • Is input signal wire for DC voltage (1 to 5V DC) or DC current (4 to 20mA DC) securely connected to the instrument input terminals? Connect the signal lead wire to the instrument input terminals securely. • Is polarity of thermocouple or compensating lead wire correct? Do codes (A, B, B) of RTD agree with the instrument terminals? Wire them properly.

The PV display keeps indicating the value which was set in the Scaling low limit setting.	<ul style="list-style-type: none"> Check if the input signal source for DC voltage (0 to 5V DC, 0 to 10V DC) and DC current (0 to 20mA DC) is normal. How to check each signal wire [DC voltage (0 to 5V DC, 0 to 10V DC)] If the input to the input terminals of the instrument is 1V DC and if the value corresponding to 1V DC is indicated, the instrument should be normal and the signal wire may be disconnected. [DC current (0 to 20mA DC)] If the input to the input terminals of the instrument is 1mA DC and if the value corresponding to 1mA DC is indicated, the instrument should be normal and the signal wire may be disconnected. Are the input lead wire terminals for DC voltage (0 to 5V DC, 0 to 10V DC) or DC current (0 to 20mA DC) securely mounted to the instrument input terminals? Mount the sensor terminals to the instrument input terminals securely.
The indication of PV display is abnormal or unstable.	<ul style="list-style-type: none"> Is sensor input or temperature unit ($^{\circ}\text{C}$ or $^{\circ}\text{F}$) correct? Select the proper sensor input and temperature unit ($^{\circ}\text{C}$ or $^{\circ}\text{F}$). Sensor correcting value is unsuitable. Set the value suitably. Is the specification of the sensor correct? Set the sensor to the proper specification. AC leaks into the sensor circuit. Use an ungrounded type sensor. There may be a piece of equipment producing inductive interference or noise near the controller. Keep the equipment producing inductive interference or noise away from the controller.
The PV display is indicating [Err 1].	<ul style="list-style-type: none"> Internal memory is defective. Contact our agency or us.

10.2 Key operation

Problem	Presumed cause and solution
<ul style="list-style-type: none"> Unable to set the SV, P, I, D, proportional cycle or alarm setting The values do not change by \triangle, ∇ key operation. 	<ul style="list-style-type: none"> Setting value lock (Lock 1 or Lock 2) is designated. Release the lock designation. During PID auto-tuning or auto-reset. In the case of PID auto-tuning, cancel the auto-tuning. It takes approximately 4 minutes until auto-reset is finished.
The setting indication does not change in the input range even if the \triangle , ∇ keys are pressed, and unable to set the value.	<ul style="list-style-type: none"> SV high or low limit value in Auxiliary function setting mode 1 may be set at the point the value does not change. Set the proper value while in the Auxiliary function setting mode 1.

10.3 Control

Problem	Presumed cause and solution
Temperature does not rise.	<ul style="list-style-type: none"> Sensor is out of order. Replace the sensor. Sensor or control output terminals are not securely mounted to the instrument input terminals. Mount the sensor or control output terminals to the instrument input terminals securely. The wiring of sensor or control output terminals is incorrect. Connect it properly.
The control output remains ON status.	<ul style="list-style-type: none"> OUT1 or OUT2 low limit value is set to 100% or greater in Auxiliary function setting mode 2. Set the value appropriately.
The control output remains OFF status.	<ul style="list-style-type: none"> OUT1 or OUT2 high limit value is set to 0% or less in Auxiliary function setting mode 2. Set the value appropriately.

• If you have any inquiries, please consult our agency or the shop where you purchased the unit.

SHINKO TECHNOS CO.,LTD. OVERSEAS DIVISION

Reg. Office : 1-2-48, Ina, Minoo, Osaka, Japan
Mail Address : P.O.Box 17, Minoo, Osaka, Japan
URL : <http://www.shinko-technos.co.jp>
E-mail : overseas@shinko-technos.co.jp

Tel : 81-727-21-2781
Fax: 81-727-24-1760