

Temperature transmitter GV4 Clamp-on

for temperature measurement on pipes

Type series GV4610



Application area

- Pharmaceutical industry
- Food industry
- Biotechnology

Features

- Compact case of stainless steel in hygienic design according to recommendations from EHEDG and 3A, degree of protection IP 65/67
- High-resolution graphic display with intuitive operation and backlight
- Patented measuring system for hygienic temperature measurement without medium contact, for pipe Ø 8...300 mm
- Quick access to device data
- Accuracy ≤ 0.25 K
- Temperature range: $-40 \dots 150$ °C
- Output signal 4...20 mA with HART® protocol
- Digital communication via PDM/EDD and FDT/DTM
- Measuring resistor Pt100, class A
- Quick and cost efficient installation
- No additional isolation required
- Measuring insert can be recalibrated, replaceable
- Fast response

Options

- Approvals/Certificates
 - Calibration certificate per EN 10204-3.1
- Degree of protection IP 69K
- Case and front cover of stainless steel 316L
- EAC declaration (upon request)

Application

The temperature transmitter GV4610 Clamp-on is used for temperature measurement and process control, mainly for sterile applications in the food and pharmaceutical industries. The temperature transmitter can be quickly and easily fitted to all existing pipework. There are no changes necessary to the piping and no welding required. The 4 operation buttons allow an easy and fast parameterisation.

Technical data

Constructional design

Design:	Hygienic case of stainless steel, continuously rotatable by $\pm 170^\circ$
Material case and front cover:	<p><u>Process connection back:</u> Stainless steel mat.-no. 1.4305 (303) Option: stainless steel mat.-no. 1.4404 (316L)</p> <p><u>Process connection bottom:</u> Stainless steel mat.-no. 1.4301 (304) Option: stainless steel mat.-no. 1.4404 (316L)</p>
Gasket:	Silicone EPDM / FKM (if degree of protection IP 69K)
Degree of protection per EN 60529:	Case of stainless steel: IP 65/67 Option: IP 69K Clamping element: IP 65
Climatic category per EN 60721 3-4:	4K4H
Material window:	Macrolon hardened Option: Non-splintering glass
Electrical connection:	Circular connector M12 Option: Cable glands <ul style="list-style-type: none"> ■ M16 x 1.5, PA black ■ M16 x 1.5, brass nickel-plated ■ M16 x 1.5, stainless steel ■ M20 x 1.5, PA black ■ M20 x 1.5, brass nickel-plated ■ M20 x 1.5, stainless steel ■ 1/2" NPT, PA black Further connections upon request
Terminal blocks:	Spring clamp terminals up to 2 mm ²
Type plate:	Adhesive label

Measuring insert

Design:	Measuring insert: \varnothing 6 mm; hygienic design. Measuring insert screwed into the connection head under spring tension.
Material:	Stainless steel Measuring tip of silver, thermally isolated via PEEK element.
Measuring resistor:	Pt100 per EN 60751, class A

Process connection

Design:	Clamping element designed for installation with : <ul style="list-style-type: none"> ■ clamping block for pipes \varnothing 8...57 mm ■ clamping shoe for pipes \varnothing 10...300 mm
Material:	Temperature resistant plastics (PVDF) with integrated isolating system, hygienic design
Pipe diameter:	See order code

Accuracy

Accuracy:	≤ 0.25 K
Temperature influence case:	typ. 0.1 K / 10 K
Response time per EN 60751 (with flowing water):	$t_{90} = 8...15$ s (including pipe)

We recommend the use of heat sink compound (see Type MT8800).

Indication

Display:	<ul style="list-style-type: none"> - High-resolution graphic display with backlight - 4-button operation - Freely configurable display modes - Continuously rotatable - Removable under voltage
----------	--

Output

Signal:	2-wire technology	4...20 mA
	Lower limit	3.8...4 mA
	Upper limit	20...21 mA
	Lower alarm current	< 3.6 mA
	Upper alarm current	> 21 mA
	Current limitation	22 mA
	Digital communication	HART [®] -protocol, version 7

Device driver:

- EDD for SIMATIC PDM
- DTM for PACTware or compatible systems (FDT compliance)

Resolution:	≤ 1 μ A
Current sensing-function:	3.55...21.5 mA selectable in steps of 0.001 mA
Load R:	$R \leq (U-12V\ DC)/0.022\ A\ [\Omega]$ U = supply voltage for HART [®] communication $R \geq 230\ \Omega$

Supply voltage

Functional range: 12...30 V DC, protected against polarity reversal
Ripple: < 5 %

Temperature ranges

Ambient: -20...80 °C
Optional:
-40...80 °C
(Display visibility is limited at temperatures below -30 °C)
Media: -40...150 °C
Storage: -40...80 °C

Tests and certificates

- EAC declaration (upon request)

Parameterisation

Parameterisation

Parameter	Values	Default setting
Device		
device ID	16 digits, freely selectable	ID:GV4 Clamp-on
Display and control unit		
temperature unit	°C, °F, °R, K	°C
lighting	on, off	on
language	English, German, Chinese	German
decimal point	auto, x.xxxx, xx.xxx, xxx.xx, xxxx.x, xxxxx	auto
display mode	four values, three values, two values, big display	three values
main value	temperature, current (%), current (mA)	temperature
secondary values	temperature, current (%), current (mA), device ID, Bargraph, HART-TAG, HART descriptor, <empty>	device ID, Bargraph
Current output		
output function	linear, invers	linear
lower range value	at any value within nominal range	0 °C
upper range value	at any value within nominal range	150 °C
lower current limit	3.8...4.0 mA	3.8 mA
upper current limit	20...21 mA	20.5 mA
alarm current	low (< 3.6 mA), high (> 21.0 mA)	low (< 3.6 mA)
HART® data		
HART® address	0...63	0
number of response preambels	5...20	5
current mode	proportional, constant	proportional

Diagnostic functions

loop-test	setting of a fixed current value at the output	3.55...21.5 mA
temperature simulation	setting a fixed temperature value	nominal range
min/max values	for temperature	/

Adjustment

Adjustment type	Description
lower adjustment	adjusts reading of mounted device at ambient temperature (affects zero and span)
upper adjustment	adjusts reading to applied temperature (affects span only)
current adjustment	adjusts current output to achieve 4 resp. 20 mA at the end of the measurement chain

Connection diagram

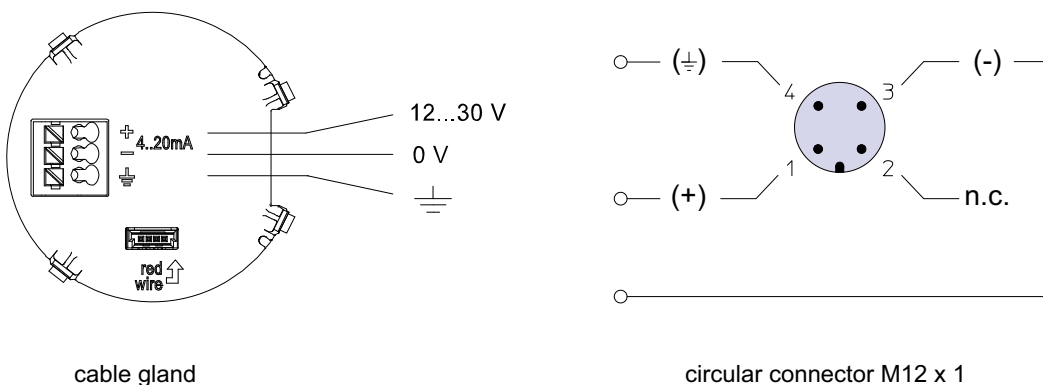

Dimensions

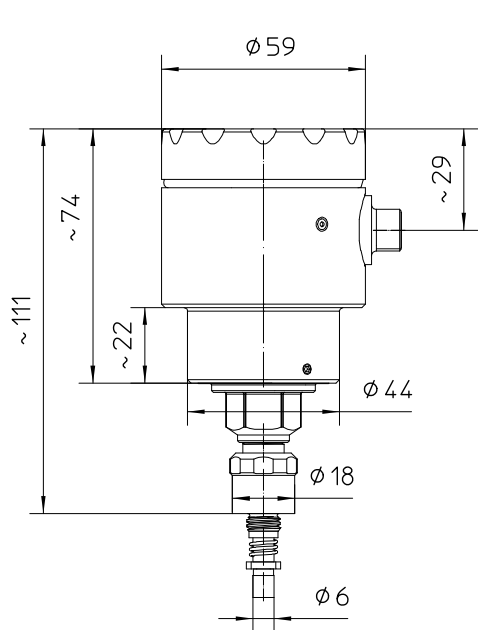

Process connection back

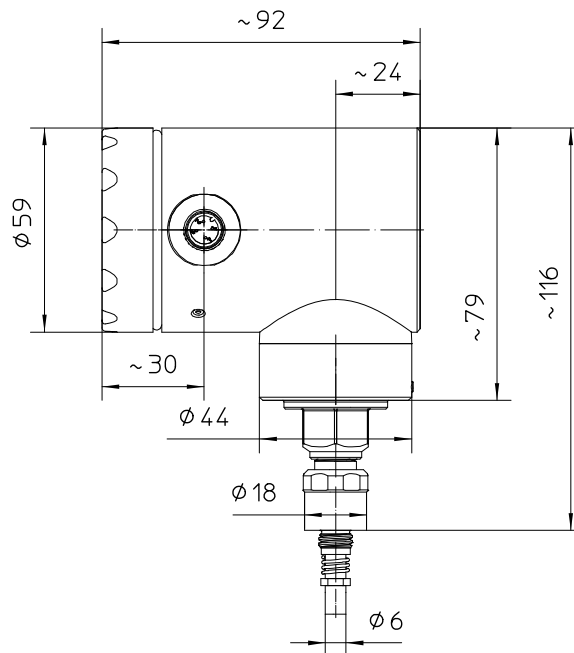

Process connection bottom

Clamping block
for pipe \varnothing 8-57

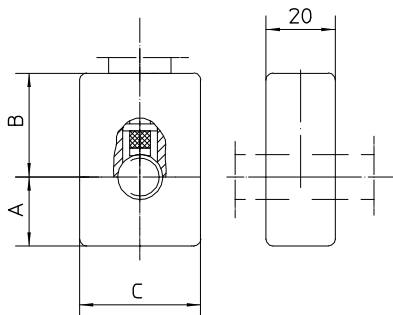

Clamping shoe
for pipe $\geq \varnothing$ 10 - $\sim \varnothing$ 300

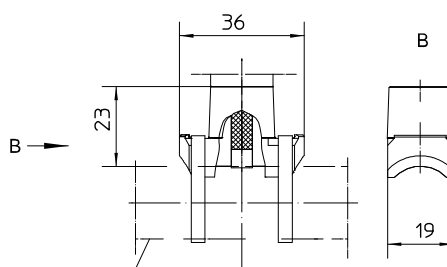

Example: \varnothing 21mm

Order details

Temperature transmitter GV4 Clamp-on for temperature measurement on pipes, Type series GV4610

Order details GV4610						
GV4610	temperature transmitter GV4 Clamp-on					
R70	position process connection	back				
R71		bottom				
F1	parameterisation	standard according to data sheet (see parameterisation table)				
F9		as per customer's specification (pls. specify)				
Q1	accuracy	≤ 0.25 K				
H21	output signal	4...20 mA, with HART®-protocol				
Y14	material case/window	stainless steel mat.-no. 1.4301/1.4305 (304/303)	window Macrolon			
Y12			window non-splintering glass			
Y13			closed, without window			
Y24		stainless steel mat.-no. 1.4404 (316L)	window Macrolon			
Y22			window non-splintering glass			
Y23			closed, without window			
T1	case degree of protection	IP 65 / IP 67				
T4		IP 69K ¹				
			default language			
M21.1	display	High-resolution graphic display with backlight, intuitive 4-button operation, quick-setup function	English			
M21.2			German			
M21.3			Chinese			
M1		without display				
T20	electrical connection	cable gland M16 x 1.5	polyamide for cable Ø 4.5-10 ²			
T21			brass nickel plated for cable Ø 5-10			
T22			stainless steel mat.-no. 1.4404 (316L) for cable Ø 5-9 ²			
T15		cable gland M20 x 1.5	polyamide for cable Ø 7-13 ²			
T16			brass nickel plated for cable Ø 7-13			
T17			stainless steel mat.-no. 1.4404 (316L) for cable Ø 8-13			
T27		cable gland 1/2" NPT	polyamide for cable Ø 5-12			
T30		circular connector M12x1 (4 pin) ²				
A4 ...		clamping elements	clamping block installation			
B2 ...	clamping shoe installation for pipe diameters ≥ 10 mm, without hose clamps					
B5 ...	clamping shoe installation for pipe diameters ≥ 10 mm, including hose clamps					
	pipe external diameter mm		dimension of the clamping elements			
			50 x 35 x 20	70 x 70 x 20	90 x 85 x 20	23 x 36 x 19
			A4 ...	A4 ...	A4 ...	B2/B5 ...
080		8.0	x	-	-	-
093		9.35	x	-	-	-
100		10.0	x	-	-	x
102		10.2	x	-	-	x
103		10.3	x	-	-	x
120		12.0	x	-	-	x
127		12.7	x	-	-	x
130		13.0	x	-	-	x
135		13.5	x	-	-	x
137		13.7	x	-	-	x
140		14.0	x	-	-	x
158		15.88	x	-	-	x
160		16.0	x	-	-	x
172		17.2	x	-	-	x

			dimension of the clamping elements				
			50 x 35 x 20	70 x 70 x 20	90 x 85 x 20	23 x 36 x 19	
			A4 . . .	A4 . . .	A4 . . .	B2/B5 . . .	
996	pipe external diameter mm	different Ø 8,0-17,9	x	-	-	-	
180		18.0	-	x	-	x	
190		19.0	-	x	-	x	
195		19.05	-	x	-	x	
200		20.0	-	x	-	x	
213		21.3	-	x	-	x	
220		22.0	-	x	-	x	
230		23.0	-	x	-	x	
240		24.0	-	x	-	x	
250		25.0	-	x	-	x	
254		25.4	-	x	-	x	
267		26.7	-	x	-	x	
269		26.9	-	x	-	x	
280		28.0	-	x	-	x	
290		29.0	-	x	-	x	
300		30.0	-	x	-	x	
318		3.8	-	x	-	x	
320		32.0	-	x	-	x	
334		33.4	-	x	-	x	
337		33.7	-	x	-	x	
340		34.0	-	x	-	x	
350		35.0	-	x	-	x	
360		36.0	-	x	-	x	
380		38.0	-	x	-	x	
998		different Ø 18.0-38.0	-	x	-	-	
381		38.1	-	-	x	x	
410		41.0	-	-	x	x	
424		42.4	-	-	x	x	
445		44.5	-	-	x	x	
483		48.3	-	-	x	x	
508		50.8	-	-	x	x	
530		53.0	-	-	x	x	
540		54.0	-	-	x	x	
570		57.0	-	-	x	x	
999		different Ø 38.1 - 57.0	-	-	x	-	
991		different Ø 10.0 - 300	-	-	-	x	
G23		material clamping elements	PVDF, temperature range media -40...150 °C				
N32		measuring resistor	1 x Pt100 per EN 60751, class A				
U1		ambient temperature	-20...80 °C				
U7			-40...80 °C				

Additional features (to be indicated in case of need, only)		
W1204	calibration certificate	per EN 10204-3.1, 3 measuring points
W1201		per EN 10204-3.1, 5 measuring points

Accessories	
MC1040	HART®-modem for USB-interface

Order code (example): GV4610 - R70 - F9 - Q1 - H21 - Y13 - M21.2 - T22 - B5240 - G32 - N32 - U1

¹ only possible with window of Macrolon, gasket made of EPDM/FKM and selected electrical connections (see footnote 2)

² suitable for degree of protection IP 69K



Zone Acticentre – CRT2 – CS 10210
156/220 Rue des Famards - 59273 FRETIN
Tél : 03 20 62 06 80 Fax : 03 20 96 95 62
Mail : contact@dimelco.com